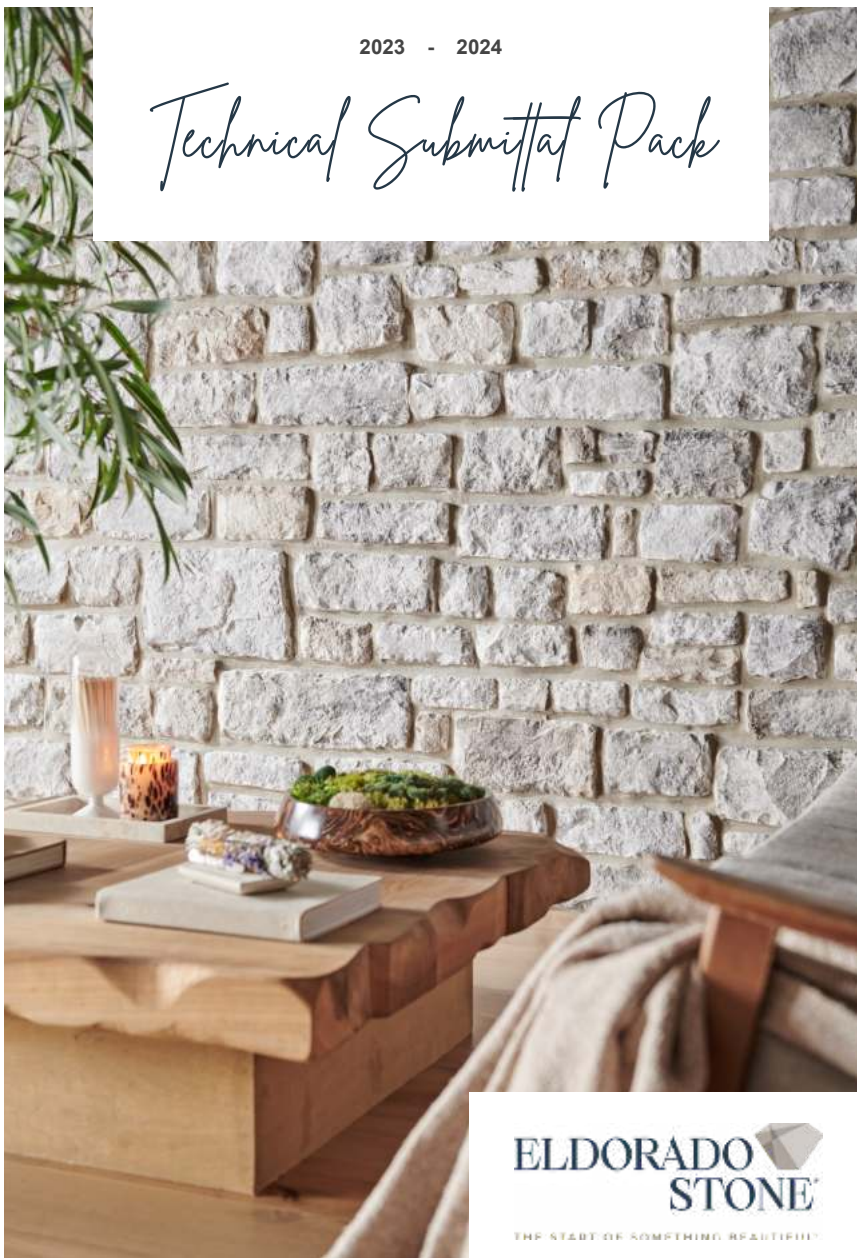


2023 - 2024

# Technical Submittal Pack



**ELDORADO**  
**STONE**

THE START OF SOMETHING BEAUTIFUL™

SUBMITTAL PACKET

# Welcome

COMPANY NAME:

CONTACT NAME:

PROJECT TITLE:

STREET ADDRESS:

CITY, STATE, ZIP:

We would like to congratulate you on your upcoming project which incorporates adhered concrete masonry veneer products. Enclosed in this packet are the required Eldorado Stone submittal forms and technical documents. We have also enclosed additional support materials and installation details commonly requested by architects and contractors.

**Visit [eldoradostone.com/resources](http://eldoradostone.com/resources) to view all digital materials available for download.**

**SUBMITTAL FORM**

**TECHNICAL DATA SHEET**

**50 YEAR WARRANTY**

**CERTIFICATE OF QUALITY**

**FREQUENTLY ASKED QUESTIONS**

**CARE & MAINTENANCE**

**INSTALLATION GUIDELINES**

**3-PART SPEC**

**ICC EVALUATION REPORT**

**MATERIAL SAFETY DATA SHEET**

As part of our commitment to service, we would like to recommend that you take advantage of our consulting services.

We have trained Technical Field Service representatives that will walk through your project with you prior to installation. This can help prevent improper installations and in some cases identify where additional stone or accessories may be needed.

Thank you again for choosing Eldorado Stone. Should you have any questions, please do not hesitate in contacting us. We are grateful for the opportunity to be a part of your project needs.

Sincerely,

Sales Representative  
Eldorado Stone, LLC

# Submittal Form

Eldorado Stone Representative:

PROJECT DETAILS	ELDORADO STONE	
PROJECT NAME:	PROFILE:	COLOR:
PROJECT ADDRESS:	APPROX SQ FOOTAGE:	
CITY / STATE / ZIP:	MANUFACTURING LOCATION: -Mfg. Location-	

Please fill in all known information.

OWNER	ARCHITECT	BUILDER	MASON
COMPANY NAME:	COMPANY NAME:	COMPANY NAME:	COMPANY NAME:
CITY, STATE:	CITY, STATE:	CITY, STATE:	CITY, STATE:
CONTACT NAME:	CONTACT NAME:	CONTACT NAME:	CONTACT NAME:
CONTACT PHONE:	CONTACT PHONE:	CONTACT PHONE:	CONTACT PHONE:

## PROJECT NOTES

---



---



---



---

Pre-Installation Project Team Meeting Scheduled?    Y    N    Date Scheduled:

Your signature below acknowledges receipt of the Eldorado Stone “Submittal Packet” and the above information is accurate to the best of your knowledge.

Received By: \_\_\_\_\_ Date: \_\_\_\_\_

Company: \_\_\_\_\_ Phone: \_\_\_\_\_

Eldorado Stone Representative: \_\_\_\_\_ Date: \_\_\_\_\_

Email completed form to: [cs@westlake.net](mailto:cs@westlake.net)

# Technical Data

Adhered Veneers & Wall Mounted Accessories

**Eldorado Stone** is designed to meet or exceed building code requirements. Independent testing confirms compliance with ICC-ES Acceptance Criteria 51 and ASTM C1670, Standard Specification for Adhered Manufactured Stone Masonry Veneer Units.

*Supporting test data is available upon request.*

Local building codes may vary by area. Always check with your local building authorities before installing stone.

*For additional technical information please visit: [www.eldoradostone.com](http://www.eldoradostone.com)*

## Ingredients

Light weight aggregate ASTM C33, C330 & C331

Portland cement ASTM C150, ACI 318

Mineral oxide pigments ASTM C979

## Code Acceptability & Certification

UL Registered

Mineral composition units

Surface burning characteristics

Flame Spread 0

Smoke Developed 0

ICC-ES ESR 1215

California Building Code

Florida Building Code

Los Angeles Research Report #25589

HUD Materials Release #910

ASTM C1670

Florida Product Approval FL 21143-R1



## Shear Bond (Adhesion)

Tested in accordance with ASTM C1670

Greater than 50 psi shear bond strength

## Absorption

Tested in accordance with ASTM C1670,  
ICC-ES Acceptance Criteria 51 & ASTM C140

## Saturated Density - Weight per Square Foot

Tested in accordance with ASTM C1670 Weight less  
than 15 lbs. per sq. ft., saturated

## Thermal Resistance

Tested in accordance with ASTM C177

R value: 0.62 (ft<sup>2</sup>-F-hr)/BTU at 1.5" thickness

## Compressive Strength

Testing in accordance with ASTM C1670

Compressive strength is greater than 2100 psi

## Wind Load Testing

Tested in accordance with ASTM E330 at

150 mph wind speed; passed

**Westlake**  
Royal Stone Solutions™

**ELDORADO**  
**STONE**  
THE START OF SOMETHING BEAUTIFUL™

[eldoradostone.com](http://eldoradostone.com) 800.925.1491

# WESTLAKE ROYAL STONE LLC ELDORADO STONE® PRODUCTS

## 50-YEAR TRANSFERABLE EXPRESS LIMITED WARRANTY

1. Subject to the following terms, Westlake Royal Stone LLC (“WRS”) warrants under this express limited warranty (“Warranty”) to the original purchaser and subsequent owners of its Eldorado Stone® brand manufactured stone or brick veneer (collectively, the “Product” or the “Products”) that for fifty (50) years from the date of sale of the Product, the Product will not blister, peel, flake, delaminate or crack excessively (each, a “Defect”) as a result of manufacturing defects when used on structures (each, a “Structure”) conforming to local building codes and installed in accordance with the National Concrete Masonry Association’s written instructions issued before and closest in time to original date of the installation of the Product in the Structure. The definition of “veneer” contained in the International Building Code is determinative for purposes of establishing what Products constitute WRS’s manufactured stone or brick veneer and are covered by this Warranty.
2. In the event of a Defect, WRS will, at its option, either: (1) pay the reasonable replacement cost of the defectively manufactured Product; (2) provide a replacement of the defective Product or a Product of a similar design; or (3) pay the reasonable cost for repair of the defective Product. This Warranty applies only to Products manufactured by WRS and does not apply to any other products or materials, including exterior walls, exterior wall envelopes, backing to which Products are secured, or water-resistive barriers.
3. This Warranty runs with the sale or transfer of the Structure into which the Products have been incorporated to subsequent owners of the Structure, but the warranty period as to such subsequent owners is limited to fifteen (15) years from the original date of sale of the Product.
4. No warranty whatsoever is made with respect to the manufacture or performance of materials or components of construction not sold or manufactured by WRS, including, but not limited to, mortar, lath, weather resistant barriers, doors, windows, sealants, flashings, roofing, copings, sheathing and framing. Further, WRS makes no warranties whatsoever with respect to aesthetics, design and engineering of the Structure into which Products are incorporated, or workmanship involved in the application of any Products warranted hereunder. The Product is not waterproof and should not be used on exterior or interior steps or risers. The Product must be incorporated into a wall assembly designed by a building professional that contains adequate mechanisms for water management. WRS has no responsibility for damage caused by moisture intrusion through the building envelope or around any of the building envelope components or by vapor transmission from the inside of the Structure to a moisture sensitive part of the wall assembly.

This Warranty is effective for sales after January 26, 2022 (“Effective Date”) and supersedes all previously published versions of this Warranty for Products sold on or after the Effective Date.

**Last Modified: January 26, 2022**

**ELDORADO**  
**STONE**

THE START OF SOMETHING BEAUTIFUL™

eldoradostone.com 800.925.1491

**WESTLAKE ROYAL STONE LLC**  
**ELDORADO STONE® PRODUCTS**

**50-YEAR TRANSFERABLE EXPRESS LIMITED WARRANTY**

5. This Warranty covers only manufacturing defects in the Products. WRS's manufacturing process has been designed to imitate the random beauty and nature of real stone. As such, stone surfaces on the Products may contain small air holes or surface anomalies. These differences add to the overall character of the Products and are not considered manufacturing defects. Changes in the appearance of Products caused by normal weathering or efflorescence, which is a natural phenomenon of all concrete products, are also not considered manufacturing defects. Normal weathering is defined as exposure to sunlight and extremes of weather and atmosphere, which will cause any colored surface to fade, chalk, or accumulate dirt or stains.
  
6. Without limiting anything else in this Warranty, WRS disclaims and assumes no liability for the following:
  - a. improper use, application or installation of Products;
  - b. use of Products as part of improperly designed or constructed assemblies or Structures or with defective adjacent materials or assemblies;
  - c. failure to follow applicable specifications, instructions and construction details;
  - d. use of any sealing or coating on the Product other than one that is silane or siloxane and based in strict compliance with sealant manufacturer's instructions;
  - e. other design or construction defects, deficiencies and failures on a Structure where Product is used;
  - f. undertaking on-site inspections or any on-site activities or making oral statements at the site;
  - g. any damage or injury whatsoever caused in whole or in part by acts of God, natural phenomenon or physical abuse, such as, but not limited to, falling objects, projectiles, fire, earthquake, floods, windstorm, hail, tornadoes, lightning, hurricanes, other abnormal weather conditions, pests, chemical fumes, foreign substances in the air, misuse, vandalism, civil disobedience, war, damage caused by remodeling or renovation;
  - h. damage resulting from moisture intrusion, mold, settlement of Structure or other Structure or wall movement;
  - i. discoloration or deterioration due to airborne contaminants, contact with any chemicals or paint, staining or oxidations;
  - j. any accumulation of water or moisture in wall assemblies;
  - k. negligence or accidents by any party or parties in maintaining the Products, including, but not limited to, use of a pressure washer or harsh or acid chemicals of any nature, including vinegar, to clean;
  - l. replacement of Product if Product is mixed with other chemicals or materials not approved by WRS in writing;
  - m. any cause beyond WRS's control; and
  - n. any workmanship, aesthetics or other damage or injury not solely and directly caused by a manufacturing defect in Products as covered under this Warranty.

**WESTLAKE ROYAL STONE LLC**  
**ELDORADO STONE® PRODUCTS**

**50-YEAR TRANSFERABLE EXPRESS LIMITED WARRANTY**

7. This Warranty is exclusive, the only warranty made by WRS with respect to the Products, and is in lieu of all other warranties or remedies of any nature whatsoever to the original purchaser or subsequent owners under any theory of liability, whether in contract, tort, statutory law or otherwise, except for actual economic damages for personal physical bodily injury. All other warranties, representations or remedies with respect to the Products, whether oral, written, express or implied or imposed by law, are disclaimed by WRS and are waived by the original and subsequent purchasers, particularly the implied warranties of merchantability or fitness for a particular purpose or arising from a course of dealing, usage or trade practice, or any warranty against patent infringement or warranty for work performed in a workmanlike manner. WRS shall not be liable under any circumstances for any incidental, special, indirect or punitive damages to any party whatsoever, including but not limited to, loss of profits, damage to the Structure or its contents, and attorney's fees. This exclusion of damages includes, but is not limited to, payments of any nature made because of actual or potential liability to others, damages to any other part of the Structure to which the Products are incorporated or damage to any other property.
8. WRS shall have no further obligation or liability of any kind, other than as stated in this Warranty, and it is further agreed and understood that the price paid for Products is consideration for the limitation of WRS's liability hereunder.
9. Warranty coverage is limited as set forth herein and does not cover labor to remove or install Products and does not cover the cost of shipping replacement Product. The remedies contained herein shall be sole and exclusive.
10. WRS's obligations under this Warranty shall only begin if the original purchaser or subsequent owner notifies WRS, in writing, within sixty (60) days of actual or constructive notice of the alleged Defect. WRS shall be allowed a reasonable period of time and authorization to remove samples of the Product, so as to perform any testing WRS deems necessary to investigate and determine the cause of the alleged Defect. The original purchaser or subsequent owner shall make temporary repairs in a timely manner to prevent further damage to the Structure, contents of the Structure, and the Products until the cause of the alleged Defect is determined and permanent repair recommendations may be made, as applicable.
11. WRS's obligation to supply replacement Product pursuant to this Warranty shall become null and void if, in the sole judgment of WRS, any of the following events shall occur: (i) if after installation of the Products there are any alterations or repairs made to the Structure that affect any component of the wall assembly of which Products are a part in any way; (ii) if the original purchaser or subsequent owner or any of their respective tenants fail to use reasonable care in maintaining the Products before and after installation; (iii) if the Products are installed in a manner that causes them to be repeatedly or continuously wet, such as if installed in the direct path of a water sprinkler, pool, jacuzzi, or similar water device; or (iv) if the Products are installed in an area that exposes them to de-icing salts or other harsh chemicals.
12. Applicability of the Magnusson-Moss Act is hereby disclaimed.

WESTLAKE ROYAL STONE LLC  
**ELDORADO STONE® PRODUCTS**

50-YEAR TRANSFERABLE EXPRESS LIMITED WARRANTY

13. Any provision of this Warranty that is prohibited or unenforceable in any jurisdiction shall, as to such jurisdiction, be ineffective to the extent of such prohibition or unenforceability without invalidating the remaining provisions hereof or affecting the validity of enforceability of such provision in any other jurisdiction.
14. WRS's failure at any time to enforce any of the terms or conditions stated herein shall not be construed to be a waiver of such provisions.
15. This Warranty shall be interpreted under the laws of the State of New York.
16. Neither the sales personnel nor other agents of WRS are authorized to make warranties about the Products. Oral statements by WRS employees or agents do not constitute warranties, shall not be relied upon by the original purchaser or subsequent owner or any third party, and are not part of the contract for sale or warranty as stated herein. No distributor, dealer or representative of WRS has the authority to change or modify this Warranty either orally or in writing in any respect. The entire and final contract is embodied in this Warranty and no other warranties are given beyond those set forth in this Warranty.



THE START OF SOMETHING BEAUTIFUL™

[eldoradostone.com](http://eldoradostone.com) 800.925.1491



**Eldorado Stone**  
C E R T I F I C A T E

O F *Quality*



DATE:

.....

ATTN:

.....

PROJECT  
TITLE:

.....

PROJECT  
CITY+STATE:

.....

ARCHITECT:

.....

STONE  
PROFILE+COLOR:

.....

GENERAL  
CONTRACTOR:

.....

MASONRY  
CONTRACTOR:

.....

*T*his letter is to certify that the product manufactured by Eldorado Stone, LLC for the project specified above will meet the Acceptance Criteria for Precast Stone Veneer set by ICC Evaluation Service, as specified in the Evaluation Report No. ESR-1215.

Sincerely,



Juan Chiquillo  
Manager - Quality  
Eldorado Stone, LLC

**ELDORADO**   
**STONE**<sup>®</sup>

THE START OF SOMETHING BEAUTIFUL™

# FREQUENTLY ASKED QUESTIONS

## **Why is Eldorado Stone® considered *The Most Believable Architectural Stone Veneer in the World*?**

Believability. It's the most important ingredient of Eldorado Stone and the most compelling reason why so many architects, builders and homeowners choose Eldorado Stone. Eldorado's distinct process handcrafts molds and creates the natural color palettes that capture all the nuances of real stone. The warmth and richness of Eldorado Stone creates unique spaces of permanence, romance and beauty; inside and out. *The Most Believable Architectural Stone Veneer in the World*. Only from Eldorado Stone.

## **What is the difference between manufactured stone veneer and natural stone?**

Manufactured stone veneer is cast from molds of real stone which makes it lighter than natural stone. Natural stone may require wall ties and footings, which, in turn, can increase installation cost and difficulty. Eldorado's architectural stone veneer is lighter weight, designed to adhere easily to a variety of structurally sound surfaces, and is capable of installations that would normally be very difficult and costly to achieve with natural stone.

## **What are the benefits of using manufactured stone?**

Installed, manufactured stone is approximately 1/3 to 1/2 the cost of natural stone. Its light weight properties eliminate the need for wall ties or footings. Manufactured stone has a 2% (approximately) waste factor versus 10% or more for natural stone.

## **Where can I install Eldorado Stone?**

Eldorado Stone can be applied to any structurally sound surface with the proper preparation. It fits nearly any building plan — large or small, interior or exterior, new residential or commercial projects — or on any remodel. For inspirational installations visit [www.eldoradostone.com/imagine](http://www.eldoradostone.com/imagine).

# FREQUENTLY ASKED QUESTIONS

## **Can I install Eldorado Stone myself?**

In general, installation of Eldorado Stone can be installed by almost anyone. However, installation does require a fundamental understanding of stone masonry. Please review the *Installation Procedures* and *How to Install* at [www.eldoradostone.com](http://www.eldoradostone.com) or contact Customer Service at 800.925.1491.

## **How does Eldorado Stone withstand freeze/thaw cycles?**

Eldorado Stone products are tested for freeze/thaw durability. As with any installation, making sure to incorporate good building practices that include proper flashing and water diversion techniques will help ensure a successful installation.

## **How much does Eldorado Stone weigh?**

Approximately 10-12 lbs. per square foot. Eldorado Stone qualifies as an adhered veneer because it weighs less than 15 lbs. per square foot.

## **Will Eldorado Stone fade?**

The base color is blended throughout and permanent mineral oxide pigments are applied and absorbed when the veneer is cast. Color becomes an integral part of the veneer and, similar to natural stone, there are minimal noticeable color changes after years of weathering.

## **How important is a good stone installation?**

As with any building material, the beauty of that product is greatly enhanced by how well it is installed. With Eldorado Stone, careful consideration regarding the type of profile and color selected, the actual installed stone “pattern”, and the type of grout technique used, are all very important factors to regard. It is always best to create a mock up board with the desired aesthetic appeal prior to installation on your project. For more information download the *Installation Procedures* and *Finishing Details* PDFs from [www.eldoradostone.com](http://www.eldoradostone.com).



## **What type of coverage can be expected?**

Approximately 100 square feet per day. This varies depending upon the stone type used and the installers ability. Stacked Stone, for instance, sold in 4" modular component panels, is easy to install and will provide coverage of up to 200 square feet in a day. Conversely, Shadow Rock, with its irregular shapes and varying stone sizes, can provide coverage of 70- 80 square feet a day.

## **Where can I buy Eldorado Stone?**

Eldorado Stone is sold by more than 1,000 authorized distributors throughout the U.S. and Canada. Please visit [www.eldoradostone.com](http://www.eldoradostone.com) and select "Contact" to find a distributor near you.

## **Where can I find knowledgeable masons?**

Your local Eldorado Stone distributor can recommend local masons that are familiar with Eldorado Stone products and installation.

## **Does Eldorado Stone meet building code requirements?**

Eldorado Stone complies with all applicable Building Code requirements. A copy of the Eldorado Stone *Technical Data Sheet* is available online at [www.eldoradostone.com](http://www.eldoradostone.com).

## **Is Eldorado Stone combustible?**

No. Eldorado Stone's listing by Underwriter's Laboratories shows zero fuel contributed and zero smoke developed. It can be installed as a façade to fireplaces and behind stoves. It is recommended the product is at least 18" away from any direct flame.

## **Can I install Eldorado Stone on overhead horizontal surfaces?**

Please verify your installation with your building official and consult with an engineer for specific design issues on your project. There are grout and mortar manufacturers that will support their product's use in these installations. Eldorado Stone's *50 Year Limited Warranty* will still cover our veneer products for manufacturing defects.

# FREQUENTLY ASKED QUESTIONS

## **Can I install Eldorado Stone near water?**

It is not recommended for use below the water line in a pool, a fountain or below grade. A high quality penetrating and breathable sealer that is either silane or siloxane-based is recommended in areas where the stone may be subject to frequent water run off.

*NOTE: A sealer may affect the stone color and may create a gloss or matte finish. Always test a small area beforehand.*

## **How thick are the stones?**

0.625" to 3.625" depending on the texture.

## **What's the thickness from the substrate to surface of the stone?**

There will be (approximately) an additional 0.5"-1" of mortar thickness behind the stone. For example, if your stone profile is 2" thick, you can expect the total thickness from the substrate to the face of the stone to be (approximately) 2.5" - 3" thick.

## **What is the R-value of Eldorado Stone?**

An average of 0.41 per inch of thickness.

## **What is the installed weight?**

The installed weight will vary depending upon the profile chosen and the mortar, grout technique, lath and lath accessories used. Eldorado Stone can weigh up to 15 lb./sq.ft. If a specific weight is needed for a project we recommend having an engineer evaluate the system.

## **How many square feet will a bag of mortar cover?**

A 94 lb. bag covers 8'-12' for the standard, full and overgrout applications and 10'-14' for the drystack applications.

## **What happens if Eldorado Stone is damaged?**

Small chips and cracks can be repaired using our *Color Touch-Up Kit* which includes easy-to-follow instructions. These kits are available from Customer Service at 800.925.1491. *Touch-Up Kits* are not made for coloring aggregate exposed by cutting stones. The best installers will bury cuts into transitions and/or hide them with mortar when grouting.



## **How do I clean the Eldorado Stone ?**

To clean dirt or other particles first try a simple soft bristle brush. If necessary use a solution of mild detergent with water and scrub the surface with a soft bristle brush. Rinse with clean water to remove any cleaning solution that might remain on the surface. If the stone has a white stain deposit (efflorescence) please contact Customer Service at 800.925.1491 for recommendations. Never use wire brushes, acid cleaners, power washers, bleach, paint remover or any other type of concrete cleaner.

## **How do I clean efflorescence?**

When efflorescence occurs, as it does with many masonry products, it is the usually the result of moisture migration through the masonry substrate. Once the moisture is on the masonry surface, it evaporates, depositing dissolved salts in the form of efflorescence. Efflorescence naturally disappears over time as long as the moisture source is controlled or eliminated. If the stain will not wash off, do not apply chemicals or cleaners to the stone. Call Eldorado customer service to discuss optional solutions.

## **Can I seal Eldorado Stone?**

It is not required to seal Eldorado Stone. A sealer will provide added protection and will usually be easier to clean if the surface becomes dirty. If you choose to use a sealer for added protection use only a silane or siloxane-based penetrating, breathable masonry sealer.

*NOTE: A sealer may affect the stone color and may create a gloss or matte finish. Always test a small area beforehand.*

## **What about protection against graffiti?**

In many areas, Eldorado Stone is considered a protection against graffiti. The color blends and uneven textures are not the best canvas for graffiti “artists.” However, if you should choose to use an anti-graffiti coating please speak directly to the manufacturer of the anti-graffiti coating product and ask your contractor to submit a test prior to installation. There are urethane and wax-based sealers that can damage the surface or cause it to “yellow.” Other sealers may encourage additional efflorescence on the stone’s surface. No type of coating should be applied until the stone has been on the wall for at least 14 to 28 days.

# FREQUENTLY ASKED QUESTIONS

## **Does Eldorado Stone require movement joints?**

Expansion joints normally pass completely through a wall. Control joints normally are on the surface of the wall and relieve strain on the skin of the wall. Terminate the veneer installation where control and expansion joints occur in the substrate. Do not span these joints with veneer because this will lead to cracking. Expansion joints in a building must be specified by the architect or engineer. The architect or engineer should consider the ASTM C 1063 control joint requirements when determining the location of control joints on any structure. Normally the weakest point on a wall is immediately above and below penetrations.

## **How do I install Eldorado Stone when there is an expansion joint?**

Treat each section as a “separate” installation. Do not span movement joints with the veneer.

## **What is Eldorado Stone’s recommendation regarding flashing around windows and doors?**

To maintain the weather-resistance of the exterior wall on which the stone products are installed, a rigid, corrosion-resistant flashing — and a means of drainage — should be installed at all penetrations and terminations of the veneer cladding. Flashing type and locations shall be in accordance with the requirements of the applicable code.

Please reference the *Finishing Details* PDF on our website. Also refer to ASTM E2112 and any information from your Window and Door manufacturer.

## **What kind of Weather Resistive Barrier (WRB) can I use?**

It is recommended to use two separate layers of WRB in all applications where WRB is specified.\* The WRB must meet the requirements of ICC-ES AC 38 *Acceptance Criteria for Water-Resistive Barriers*. When using Grade D paper, a 60 minute rating is recommended. Felt paper must be clearly marked that it meets the requirements of ASTM D 226 for #15 or #30 asphalt saturated felt.\*\* It is acceptable to use one layer of housewrap covered by a second layer of WRB meeting the requirements above. The WRB should be free of tears or holes.

\* *It is acceptable to use one layer of WRB on interior applications.*

\*\* *Felt meeting ASTM D 4869 or non-ASTM #15 felt is not recommended for use behind veneer.*



## **Should I use a rainscreen drainage plane system?**

Eldorado Stone veneer does not require the use of a rainscreen drainage plane system for all applications. However, some building codes now require the use of rainscreen drainage plane systems behind cladding materials such as manufactured veneer. If you are installing veneer in these areas, or wish to provide additional protection against entrapped moisture, download the *Installation Procedures* PDF from [www.eldoradostone.com](http://www.eldoradostone.com) for more detailed information.

## **What is the fire rating of Eldorado Stone?**

Eldorado Stone has been tested for fire hazard and shows zero flame spread and zero smoke developed. Since Eldorado Stone is non-combustible there is no fire rating.

## **Can we install Eldorado Stone around a fireplace?**

Eldorado Stone can be installed around a fireplace. The veneer has to be a minimum of 18" from any open flame. Download the *Installation Procedures* PDF from [www.eldoradostone.com](http://www.eldoradostone.com) for more detailed information.

## **What measures should be taken for hot/cold weather installations?**

For cold weather installations ambient temperature should be 40°F or higher at the time Eldorado Stone veneer is applied. If the temperature is below 40°F, mortar should be heated between 40°F – 120°F (not to exceed 140°F). Any mortar that freezes should be discarded. Wall surfaces may need to be covered and heated after installation of veneer to avoid freezing the mortar. See section 2104.3 of the International Building Code (IBC) for additional cold weather requirements.

Applications in hot weather conditions should follow the requirements in section 2104.4 of the IBC. Mortar should be kept under 120°F and be used within 2 hours of initial mixing.

## **Does Eldorado Stone need a ledge detail at the bottom for structural support or can it hang freely?**

No footings or support ledges are needed. The product is an adhered veneer and is supported on the wall by the bond of the mortar to the stone and scratch coat.



# FREQUENTLY ASKED QUESTIONS

## What measures should be taken for applications over 30 feet?

Eldorado Stone can be installed on any structurally sound surface. For all applications up to 30' in height we recommend following our *Installation Procedures*. Unless special construction techniques accommodates differential movement — which is approved by a code official — there is a 30' height limit for installations over wood-frame construction. For installations over non wood-framed sheathing (e.g., steel studs, concrete walls, etc.) there's no specific height limitation. However, Eldorado Stone recommends that you consult with a building code official regarding any project exceeding 30' in height.

## What kind of wind-load testing has been applied to Eldorado Stone veneer?

Eldorado Stone has tested grouted and dry-stacked applications in accordance with: ASTM E330, *Standard Test Method for Structural Performance of Exterior Windows, Doors, Skylights and Curtain Walls by Uniform Static Air Pressure Difference (Modified)*. Wall samples were subjected to positive and negative structural load tests at 57.6 psf (150 mph wind speed) and 60 psf (153 mph wind speed) pressure differentials. After completion of each load a visual inspection revealed no visible damage or cracking.

## Where can I learn more about Eldorado Stone?

Contact your Architectural Representative, visit [www.eldoradostone.com](http://www.eldoradostone.com) or talk to your local distributor to find out more about the many inspirational and technical attributes that make Eldorado Stone *The Most Believable Architectural Stone Veneer in the World™*.



[eldoradostone.com](http://eldoradostone.com) 800.925.1491

# Care & Maintenance

Thank you for choosing Eldorado Stone for your project! Eldorado Stone products are virtually maintenance free.

---

## CLEANING

To clean dirt or other particles first try a simple soft bristle brush. If necessary use a solution of mild detergent with water and scrub the surface with a soft bristle brush. Rinse with clean water to remove any cleaning solution that might remain on the surface. If the stone has a white stain deposit (efflorescence) please contact Customer Service at (800) 925-1491 for recommendations. Never use wire brushes, acid cleaners, power washers, bleach, paint remover or any other type of concrete cleaner.

---

## EFFLORESCENCE

When efflorescence occurs, as it does with many masonry products, it is the usually the result of moisture migration through the masonry substrate. Once the moisture is on the masonry surface, it evaporates, depositing dissolved salts in the form of efflorescence. Efflorescence naturally disappears over time as long as the moisture source is controlled or eliminated. If the stain will not wash off, do not apply chemicals or cleaners to the stone. Call Eldorado customer service to discuss optional solutions.

---

## PROTECTIVE TREATMENT

It is not required to seal Eldorado Stone. A sealer will provide added protection and will usually be easier to clean if the surface becomes dirty. If you choose to use a sealer for added protection use only a silane or siloxane-based penetrating, breathable masonry sealer.

*Note: A sealer may affect the stone color and may create a gloss or matte finish. Always test a small area beforehand.*



eldoradostone.com 800.925.1491

# INSTALLATION GUIDELINES

**Eldorado Stone** endorses and supports the National Concrete Masonry Association - Manufactured Stone Veneer (NCMA-MSV) Installation Guidelines. The mission of the NCMA organization is to advance the growth of the manufactured masonry veneer products industry through proactive technical, advocacy, and awareness efforts.

One of the most important projects completed by the NCMA Technical Committee was the development of a highly detailed and carefully researched installation guide. The latest version of that guide can be downloaded at [www.eldoradostone.com/resources](http://www.eldoradostone.com/resources). These guidelines are intended to share over 50 years of knowledge, experience and understanding regarding the proper installation of manufactured stone veneer products. For any specific or unique installation questions or challenges, including:

- Traditional masonry installation methods
- Installation over cement board using polymer modified mortar
- Installation over thick foam; fastener selection
- Installation of large format profiles

Please contact Eldorado Stone's Technical Support Service directly at 800.925.1491.



**Note:** It is important to recognize that Eldorado Stone and Brick veneer products are an adhered veneer or façade which are attached directly to a cementitious substrate for purposes of providing ornamentation and a first layer of weatherization protection. Adhered Concrete Masonry Veneers are not intended as a structural product or a waterproofing element. Most importantly, the real subject matter expert is your local building department and the local building code. Your local building code will supersede all other written or verbal installation guides provided by Eldorado Stone or the NCMA. Go to [ncma.org/manufactured-stone-veneer](http://ncma.org/manufactured-stone-veneer) for more information about the NCMA.

# Installation Guide and Detailing Options for **Compliance with ASTM C1780**

For Adhered Manufactured Stone Veneer 5th Edition, 5th Printing

NATIONAL  
CONCRETE MASONRY  
ASSOCIATION



# NCMA MSV

# TABLE OF CONTENTS

Definitions/Abbreviations.....	4
References.....	4
Design and Construction Considerations.....	7
Material Requirements.....	7
Surface Preparation.....	9
Installation of Adhered Manufactured Stone Veneer.....	12
Cautions.....	14
<b>Drawings/Cross Sections</b>	
Figure 1. Installation Over Wood Framing.....	15
Figure 2. Installation Over Concrete Masonry Units.....	16
Figure 3. Wall Assembly Transition.....	17
Figure 4a. Typical Frame Wall Section.....	18
Figure 4b. Typical Frame Wall Section Over Continuous Rigid Insulation.....	19
Figure 5a. Foundation Wall Base.....	20
Figure 5b. Foundation Wall Base Over Continuous Rigid Insulation.....	21
Figure 6. Foundation Wall Base-AMSV Overlapping Foundation.....	22
Figure 7. Foundation Wall-Transition to AMSV Continuing Down Foundation.....	23
Figure 8a. Cladding Transition.....	24
Figure 8b. Cladding Transition Over Continuous Rigid Insulation.....	25
Figure 9a. Outside Corner.....	26
Figure 9b. Outside Corner Over Continuous Insulation.....	27
Figure 10a. Inside Corner.....	28
Figure 10b. Inside Corner Over Continuous Insulation.....	29
Figure 11a. Horizontal Transition.....	30
Figure 11b. Horizontal Transition Over Continuous Insulation.....	31
Figure 12a. Vertical Transition.....	32
Figure 12b. Vertical Transition Over Continuous Insulation.....	33
Figure 13a. Open Eave-Overhang.....	34
Figure 13b. Open Eave-Overhang Over Continuous Insulation.....	35
Figure 14. Open Eave-Flush.....	36
Figure 15. Rake-Overhang.....	37
Figure 16. Rake-Flush.....	38
Figure 17a. Side Wall-Composition Shingles.....	39
Figure 17b. Side Wall-Composition Shingles Over Continuous Insulation.....	40
Figure 18. Side Wall-Composition Shingles Curbing.....	41
Figure 19. Side Wall-Tile Roofing.....	42
Figure 20. Side Wall-Tile Roofing Curbing.....	43
Figure 21a. Window Sill.....	44

# TABLE OF CONTENTS (continued)

## Drawings/Cross Sections (continued)

Figure 21b. Window Sill Over Continuous Insulation .....	45
Figure 22. Window Jamb .....	46
Figure 23. Window Head .....	47
Figure 24. Kick-Out Flashing .....	48
Figure 25. Cricket .....	49
Figure 26. Chimney Chase .....	50
Figure 27. Wood Column with Penetration Through Cap .....	51
Figure 28. Penetration, Flanged .....	52
Figure 29. Penetration Non-Flanged, with Building Paper WRB .....	53
Figure 30. Penetration Non-Flanged, with Housewrap WRB ..	54
Figure 31. Penetration, Fixture .....	55
Figure 32. Penetration, Dryer Vent .....	56
Figure 33. Deck Termination .....	57
Figure 34. Wall Cap .....	58
Figure 35. Wall Assembly-Rainscreen System-Drainage System ..	59
Figure 36. Wall Assembly-Rainscreen System-Strapped .....	60
Figure 37. Foundation Wall Base-Rainscreen System .....	61
Figure 38. Typical Wall Section-Rainscreen System .....	62
Figure 39. Retaining Wall (CMU) .....	63
Figure 40. Stone Wrap Under Straight Overhang .....	64
Figure 41a. Forward Mounted Commercial Window .....	65
Figure 41b. Forward Mounted Commercial Window Over Continuous Insulation .....	66
Figure 42. Forward Mounted Commercial Window-Top View ...	67
Figure 43. Commercial Storefront Window-Top View .....	68
Figure 44. Commercial Storefront Window .....	69
Figure 45. Wall-Section Multi-Floor Joint Detail .....	70
Figure 46a. Wall-Section CMU .....	71
Figure 46b. Wall-Section Over Continuous Rigid Insulation	72
Figure 47. Wall-Section Parapet with Stone Cap .....	73
Figure 48. Wall-Section Parapet with Steel Cap .....	74
<b>Notes</b> .....	75

### National Concrete Masonry Association

13750 Sunrise Valley Drive  
Herndon, VA 20171  
Phone: 703.713.1900

[www.ncma.org](http://www.ncma.org)

## Disclaimer

This Guide addresses generally accepted methods and details for the installation of Adhered Manufactured Stone Veneer. To the best of our knowledge, it is correct and up to date. The document, however, is designed only as a guide and it is not intended for any specific construction project. NCMA makes no express or implied warranty or guarantee of the techniques, construction methods or materials identified herein.

It is understood that there are alternative means or methods that might be required and/or recommended based on project conditions, manufacturer's recommendations, or product characteristics.

This Guide is for builders, architects, designers, masons, installers and other construction professionals who can interpret the illustrations and typical applications of Adhered Manufactured Stone Veneer presented. Details in this guide that address the installation and detailing of Adhered Manufactured Stone Veneer and its interface with other building components are not intended as specific recommendations. It is the responsibility of all design and construction professionals to determine the applicability and appropriate application of any detail to any specific project.

## About

The National Concrete Masonry Association (NCMA) unites, supports, and represents the producers and suppliers of concrete masonry systems - including concrete masonry, manufactured stone veneer, segmental retaining walls, and other hardscape systems. NCMA supports the growth of the manufactured masonry veneer products industry through proactive technical, advocacy, and awareness efforts.

Copyright © 2021 by the National Concrete Masonry Association. All rights reserved.  
5<sup>th</sup> Edition, 5<sup>th</sup> Printing

## DEFINITIONS

**Adhered Manufactured Stone Veneer (AMSV)** — lightweight, architectural, non-load-bearing product that is manufactured by wet cast blending of cementitious materials and aggregates, with or without pigments, admixtures, or other materials to simulate the appearance of natural stone and other masonry materials.

*Note: NCMA recognizes there are many names used to describe Adhered Manufactured Stone Veneer products. Adhered Manufactured Stone Veneer is used commonly throughout the industry and by some manufacturers. In the International Building Code, Adhered Manufactured Stone Veneer products are referred to as Adhered Masonry Veneer. This guide will use AMSV (Adhered Manufactured Stone Veneer) when referencing the product.*

**Backup** — The interior or exterior assembly to which AMSV systems are installed.

**CMU** — Concrete masonry unit.

**Corrosion Resistant** — A material that is intrinsically resistant to degradation or physically or chemically treated to be so under expected exposure conditions. Examples include: plastic-based materials stabilized for exposure to UV light, galvanized ferrous metals, and stainless steel.

**Fasteners** — Corrosion resistant hardware used to secure lath, screed, and flashing materials to backup systems.

**Flashing** — Corrosion resistant material used to restrict the movement of water around any intersection or projection of materials in an assembly.

**Lath** — Corrosion resistant mesh building material fastened to the substrate to act as base for adhering mortar.

**Mortar** — A mixture of cementitious material, water, and aggregate, with or without the addition of admixtures or additives to alter one or more plastic or hardened properties, used to bond masonry construction materials together and fill spaces between.

**Pointing Mortar** — Also known as grouting mortar, mortar mixture used to fill joints and cavities in AMSV construction.

**Mortar Scratch Coat** — Base coat of mortar used during the installation of AMSV; cross-raked to improve bond of subsequent mortar layers.

**Mortar Screen** — Sheet material installed to prevent the mortar scratch coat from filling the drainage space behind an AMSV assembly containing a rainscreen system.

**Mortar Setting Bed** — Mortar used to adhere the AMSV to the substrate or scratch coat.

**Water Resistive Barrier (WRB)** — Material used to restrict the transmission of water to the surface behind.

## REFERENCES

AC191 — ICC-ES Acceptance Criteria for Metal Plaster Bases (Lath)

AC275 — ICC-ES Acceptance Criteria for Glass Fiber Lath used in Cementitious Exterior Wall Coating or Exterior Cement Plaster (Stucco)

AC376 — ICC-ES Acceptance Criteria for Reinforced Cementitious Sheets used as Wall and Ceiling Sheathing and Floor Underlayment (Cement Board)

ANSI Accredited Evaluation Service — (or equivalent) third-party organization that issues an evaluation report affirming a specific building product meets building code requirements.

International Code Council - Evaluation Service (ICC-ES) — An organization that performs technical evaluations on building products, components, and construction methods for building code compliance. In the case where the building code is silent or ambiguous as to a product's requirements or a specific construction method, ICC-ES may develop "Acceptance Criteria" (AC) for the product or construction method. [www.icc-es.org](http://www.icc-es.org)

International Building Code — Building code that provides the minimum requirements for safety, health, and welfare of life and property from hazards of the built environment. The provisions of this code apply to the construction, alteration, addition, replacement, repair, use and occupancy of all buildings except one and two family dwellings, and single-family townhomes not more than three stories in height. [www.iccsafe.org](http://www.iccsafe.org)

International Residential Code — Building code that provides minimum requirements for safety, health, and welfare of life and property from hazards of the built environment. The provisions of this code apply to the construction, alteration, addition, replacement, repair, use and occupancy of detached one and two family dwellings and single-family townhomes not more than three stories in height. [www.iccsafe.org](http://www.iccsafe.org)

ANSI — American National Standards Institute, [www.ansi.org](http://www.ansi.org)

ANSI A118.1 — American National Standards Institute Specifications for Dry-Set Portland Cement Mortar

ANSI A118.4 — American National Standards Institute Specifications for Modified Dry-Set Cement Mortars

ANSI A118.15 — American National Standards Institute Specifications for Improved Modified Dry-Set Cement Mortar

TMS 402 — Building Code Requirements for Masonry Structures. This standard is produced through the efforts of The Masonry Society (TMS). [www.masonrysociety.org](http://www.masonrysociety.org)

## REFERENCES (continued)

TMS 602 — Specification for Masonry Structures. This standard is produced through the efforts of The Masonry Society (TMS). [www.masonrysociety.org](http://www.masonrysociety.org)

ICRI — International Concrete Repair Institute, Technical Guideline No. 310.2. [www.icri.org](http://www.icri.org)

ASTM International — ASTM is a developer of technical standards for products, systems, and services. [www.astm.org](http://www.astm.org)

ASTM C270 — Standard Specification for Mortar for Unit Masonry

ASTM C482 — Standard Test Method for Bond Strength of Ceramic Tile to Portland Cement Paste Standard Specification for Metal Lath

ASTM C578 - Standard Specification for Rigid, Cellular Polystyrene Thermal Insulation

ASTM C847 — Standard Specification for Surface Applied Bonding Compounds for Exterior Plastering

ASTM C933 — Standard Specification for Welded Wire Lath

ASTM C979/979M — Standard Specification for Pigments for Integrally Colored Concrete

ASTM C1032 — Standard Specification for Woven Wire Plaster Base

ASTM C1059/1059M — Standard Specification for Latex Agents for Bonding Fresh to Hardened Concrete

ASTM C1063 — Standard Specification for Installation of Lathing and Furring to Receive Interior and Exterior Portland Cement Based Plaster

ASTM C1289 - Standard Specification for Faced Rigid Cellular Polyisocyanurate Thermal Insulation Board

ASTM C1325 — Standard Specification for Non-Asbestos Fiber-Mat Reinforced Cementitious Backer Units

ASTM C1384 — Standard Specification for Admixtures for Masonry Mortars

ASTM C1670/C1670M — Standard Specification for Adhered Manufactured Stone Masonry Veneer Units

ASTM C1714/C1714M — Standard Specification for Pre-blended Dry Mortar Mix for Unit Masonry

ASTM C1780 — Standard Practice for Installation Methods for Adhered Manufactured Stone Masonry Veneer

ASTM C1788 - Standard Specification for Non Metallic Plaster Bases (Lath) Used with Portland Cement Based Plaster in Vertical Wall Applications

ASTM C1861 — Standard Specification for Lathing and Furring Accessories, and Fasteners, for Interior and Exterior Portland Cement-Based Plaster

ASTM E2556/E2556M — Standard Specification for Vapor Permeance Flexible Sheet Water-Resistive Barriers Intended for Mechanical Attachment

ASTM D226/D226M — Standard Specification for Asphalt Saturated Organic Felt Used in Roofing and Water Proofing

ASTM F1667 — Standard Specification for Driven Fasteners, Nails, Spikes, and Staples



**Table 1: AMSV Installation Requirements Summary<sup>1</sup>**

Sheathing <sup>5</sup>	Substrate <sup>5</sup>	Water Resistive Barrier <sup>2</sup>	Lath Type	Fasteners <sup>3</sup>	Scratch Coat	Setting Bed Mortar
<b>Backup: Interior Wood or Steel Stud Framing, Maximum Spacing 16 in. (406 mm)<sup>4,10</sup></b>						
<ul style="list-style-type: none"> <li>Gypsum Wall Board</li> <li>Plywood</li> <li>OSB</li> <li>Fiber Board</li> </ul>	Lath & Scratch Coat	Optional <sup>6</sup>	Any approved lath	Corrosion Resistant; minimum penetration ¼ inch (19 mm) into wood framing member or ⅜ in. into Steel framing member	Type N or S mortar complying with ASTM C270 or ASTM C1714; minimum nominal thickness ½ in. (13 mm)	See Table 2
Optional when sheathing is non-structural	Cement Board	Not required	Not required	Corrosion-resistant cement board screws	Not required	ANSI A118.4 or ANSI A118.15
<b>Backup: Exterior Wood or Steel Stud Framing; maximum spacing 16 in. (406 mm)<sup>10</sup></b>						
<ul style="list-style-type: none"> <li>Gypsum Wall Board</li> <li>Plywood</li> <li>OSB</li> <li>Fiber Board</li> </ul>	Lath & Scratch Coat	Minimum 2 layers WRB	Any approved lath <sup>7</sup>	Corrosion Resistant; minimum penetration ¼ inch (19 mm) into wood framing member or ⅜ in. into Steel framing member	Type N or S mortar complying with ASTM C270 or ASTM C1714; minimum nominal thickness ½ in. (13 mm)	See Table 2
	Cement Board	Minimum 1 layer WRB	Not required	Corrosion-resistant cement board screws	Not required	ANSI A118.4 or ANSI A118.15
<b>Backup: Concrete or Concrete Masonry<sup>8,9,10</sup></b>						
Not applicable	None (when surface is suitable for direct bonding)	Not applicable	Not applicable	Not applicable	Not applicable	See Table 2
	Lath and scratch coat (when required for bonding)	Optional <sup>9</sup>	Any approved Lath <sup>7,9</sup>	Corrosion resistant concrete screws, masonry nails, or powder actuated fasteners <sup>9</sup>	Type N or S mortar complying with ASTM C270 or ASTM C1714; minimum nominal thickness ½ in. (13 mm) <sup>9</sup>	See Table 2
	Cement board	Not applicable	Not applicable	Corrosion resistant concrete screws with washers	Not required	ANSI A118.4 or ANSI A118.15
<b>Backup: Clay Masonry<sup>8,9,10</sup></b>						
Not applicable	Lath and Scratch Coat	Optional <sup>9</sup>	Any approved Lath	Corrosion resistant concrete screws, masonry nails, or powder actuated fasteners	Type N or S mortar complying with ASTM C270 or ASTM C1714; minimum nominal thickness ½ in. (13 mm)	See Table 2
	Cement Board	Not required	Not applicable	Corrosion resistant concrete screws with washers	Not required	ANSI A118.4 or ANSI A118.15

<sup>1</sup> Refer to AMSV manufacturer for installation recommendations addressing conditions not listed.

<sup>2</sup> WRB complying with ASTM D226 Type I, ASTM E2556 Type I or II, or equivalent.

<sup>3</sup> Fastener type must comply with ASTM C1861 and spacing must comply with ASTM C1063 for attachment of lath. For cement board attachment, refer to cement board manufacturer

installation instructions. Refer to Tables 3 and 4 for minimum fastening requirements for direct attachment of AMSV systems over continuous insulation.

<sup>4</sup> For interior applications exposed to moisture, refer to corresponding exterior wall detailing requirements.

<sup>5</sup> Sheathing/substrate material shall be approved for intended application and installed in accordance with manufacturer's recommendations.

<sup>6</sup> A single layer of WRB is recommended where the sheathing/substrate is moisture sensitive.

<sup>7</sup> Approved lath options are listed in 'Material Requirements' section under 'Lath' in this guide.

<sup>8</sup> AMSV systems cannot be installed over existing anchored masonry veneers.

<sup>9</sup> When installing AMSV over concrete or concrete masonry walls where good bond cannot be achieved or the concrete or concrete masonry is unsound, install AMSV over lath.

<sup>10</sup> Backup systems should be designed to limit out-of-plane deflections to l/360 when subjected to 42% of the components and cladding wind pressure.

## INTRODUCTION

This guide focuses on the installation of AMSV systems for backup assemblies addressed in the summary table. Other backup systems, such as structural insulated panels (SIPs), may require a specifically-designed system of installation for AMSVs. AMSV systems should not be installed over deteriorating or unsound backup assemblies or exterior insulation and finishing systems (EIFS).

## DESIGN AND CONSTRUCTION CONSIDERATIONS

This Installation Guide assumes that construction personnel have knowledge of the materials described and their knowledge and experience of proper methods of installation.

Prior to commencing activity related to the scope of this Guide, review all adjacent products and other work that precedes the installation of AMSV to ensure that proper workmanship is reflected and that there are no recognizable errors or deficiencies that may compromise the installation or performance of the AMSV.

### Quality

A successful project requires the use of quality materials, proper design and detailing for the application, and a high standard of care during installation. Unfortunately, the execution of these components in the field can be subject to value-engineering resulting in materials selected based solely on price and installation techniques that focus on speed rather than quality. While the performance of AMSV systems depends upon all three of these components, field workmanship issues tend to be the dominate source of problems when performance issues surface in the field. Installing AMSV in accordance with the recommended practices of this guide and ASTM C1780 helps to ensure AMSV systems perform as intended for decades.

### Building Code Requirements

Building code requirements vary from area to area. Check with local authorities for building code requirements for your area and application. Carefully read all sections of this guide and follow the manufacturer's installation instructions before proceeding with your AMSV application. In the event the manufacturer's installation instructions conflict with the intent of statements made in this document, contact the manufacturer for additional guidance.

### Project Site Requirements

Jobsite safety is outside of the scope of this guide, however, users should always follow proper job site safety requirements including local, state, and federal laws when installing AMSV products and systems.

## MATERIAL REQUIREMENTS

### Units

AMSV units installed in accordance with this guide must meet the minimum requirements of ASTM C1670/C1670M.

### Flashing

All flashing and flashing accessories must be corrosion resistant and integrated with the WRB materials (if present). For exterior applications, flashing must be installed at all through-wall penetrations and at lower boundaries of AMSV installations. Flashing is not required for interior applications of AMSV systems not exposed to water. For interior applications that are exposed to water, treat as an exterior assembly.

In some applications, the use of self-adhering flashing, also known as flashing tape, can be used. It is recommended that applicable building codes as well as manufacturer's instructions are reviewed and followed to ensure they are permissible for the given project or application. Additionally, the manufacturer of the AMSV should be contacted prior to construction to ensure the compatibility of the two products.

### Rainscreen Drainage Plane Systems

Rainscreens are optional building techniques used to improve the drainage of incidental water behind the cladding and reduce drying time. Rainscreen products (such as drainage mats or formed polymer sheeting) or construction techniques (such as strapping or furring) that create a capillary break/air space between the cladding and the water resistive barrier can be effectively incorporated into AMSV applications. Refer to the manufacturer's recommendation for rainscreen / drainage system applications with adhered manufactured stone veneer wall systems. Details of various applications utilizing rainscreen drainage plane systems can be found in Figures 35-38. Building codes may allow a single layer of a water resistive barrier when a drainage space is incorporated in the wall system (i.e. rainscreen). Requirements for rainscreens vary by region. Verify local jurisdictional requirements regarding the use and application of rainscreens and/or drainage products.

### Weep Screeds and Casing Beads

Weep screeds and casing beads must be corrosion resistant, with weep screeds having a minimum vertical attachment flange of 3.5 inches (89 mm) that terminates behind the water resistive barrier (if present). The minimum thickness of metal weep screeds and casing beads should not be less than 0.0179 inches (0.45 mm) (26 gage). For plastic weep screeds or casing beads, the minimum thickness is 0.050 inches (1.3 mm).

## Lath

Multiple lath materials have been used successfully for the installation of AMSV systems, including:

- 2.5 lb/yd<sup>2</sup> (1.4 kg/m<sup>2</sup>) (or heavier) self-furring metal lath meeting ASTM C847;
- Welded wire lath complying with ASTM C933;
- 18 gauge (or heavier) woven wire lath meeting ASTM C1032; or
- The lath product is consistent with the AMSV manufacturer's installation instructions and has an evaluation acceptance report from an accredited evaluation service showing compliance with ICC-ES Acceptance Criteria 275 (AC275), or equivalent, and ASTM C1788.

All lath and lath accessories must be corrosion resistant, consisting of either galvanized or stainless steel materials or consisting of materials complying with AC 275, and ASTM C1788. All lath material must be self-furred or use self-furring fasteners. Refer to Table 1 of this guide for specific lath and fastener recommendations.

## Fasteners

Corrosion resistant fasteners are used to secure flashing and lath or cement board to the backup system. A variety of fasteners are available such as staples, screws, and nails, provided the heads or washers of these fasteners are large enough to not pull through the lath or cement board and the fastener is of sufficient length to penetrate into the supporting material. For specific fastener selection criteria, refer to ASTM C1861.

- Wood framing - For lath, corrosion resistant staples, corrosion resistant roofing nails, or corrosion resistant screws and washers. For cement board, corrosion resistant cement board screws as recommended by the cement board manufacturer. Fasteners must be of sufficient length to penetrate a minimum of 3/4 inch (19 mm) into framing members.
- Metal framing or panels - For lath, corrosion resistant staples, corrosion resistant roofing nails, or corrosion resistant screws and washers. For cement board, corrosion resistant cement board screws as recommended by the cement board manufacturer. Fasteners must be of sufficient length to penetrate a minimum of 3/8 inch (9.5 mm) through metal studs or panels.
- Masonry or concrete walls or panels - Corrosion resistant concrete screws or powder actuated fasteners (or cap fastener). For cement board, use 1 3/4 inch to 2 1/4 inch long 3/16 inch diameter concrete screws with 1-1/4" diameter 25 gage galvanized washer.

## Cement Board

Cement board may be used in place of lath and scratch coat, if desired. When used, cement board must comply with ASTM C1325. They must also be evaluated

for interior or exterior use in accordance with ICC-ES AC308 based on the desired applications. When using cement board, only modified mortars complying with ANSI A118.4 or ANSI A118.15 should be used as the setting bed mortar. Do not use conventional mortars (Type S or N) with cement board installations. Refer to ASTM C1780 and manufacturer recommendations for additional details on cement board installations. Refer to Figures 4a and 4b for references to the primary difference between lath and cement board applications. Other construction details illustrated in this guide are applicable to cement boards installations as well.

It is permitted to use one layer of water-resistive barrier between cement board and substrate. For exterior applications, joints in cement board should be treated per manufacturer's recommendations with modified mortars meeting ANSI A118.4 or ANSI A118.15 and 4-in. (100 mm). wide alkali-resistant fiberglass mesh tape. For interior applications, joints in cement board should be treated per manufacturer's recommendations with modified mortars meeting ANSI A118.4 or ANSI A118.15 and 2-in (50 mm). wide alkali-resistant fiberglass mesh tape.

## Mortar

Mortars used for the installation of AMSV systems can be grouped into three different categories; scratch coat mortar, setting bed mortar, and pointing mortar. Depending upon the type of mortar used and whether it is batched on site or delivered premixed to the project, each mortar must meet minimum requirements as described below:

**Scratch Coat Mortars** – Scratch coat mortars are applied directly to the lath or substrate to which AMSV systems are adhered. As the name implies, this first layer of mortar is intentionally scratched or roughened before hardening to provide enhanced mechanical bond between the scratch coat and setting bed mortars. Recommendations for the scratch coat mortar are as follows:

- Site Mixed: Meets the requirements of ASTM C270 Type N or Type S
- Preblended: Meets the requirements of ASTM C1714 /C1714M Type N or Type S

**Setting Bed Mortars** – After the scratch coat mortar has cured sufficiently, the setting bed mortar is used to adhere the AMSV units to the backing. The setting bed mortar is applied directly to the scratch coat or to the back of the AMSV units (back-buttering), or a combination of both application methods. Recommendations for setting bed mortars based on specific applications are described as follows in Table 2.

**Pointing Mortars** – Pointing mortars, also referred to as grouting mortars or mortar used to grout mortar joints, are used to fill the joints between individual AMSV units once the setting bed mortar has sufficiently cured. Not

**Table 2: Application Based Setting Bed Mortar Recommendations<sup>1</sup>**

Application	Type N Mortar (ASTM C270 or ASTM C1714)	Type S Mortar (ASTM C270 or ASTM C1714) or ANSI A118.1 Mortar	ANSI A118.4 or ANSI A118.15 <sup>5</sup> Mortar
<b>Interior Applications</b>			
Less than 10 ft (3 m) in height above finished floor	Recommended	Recommended	Recommended
All other interior applications	Not Recommended	Recommended	Recommended
<b>Exterior Single Family Residential Applications</b>			
Grouted <sup>2</sup>	Not Recommended	Recommended	Recommended
All other exterior single family residential applications	Not Recommended	Recommended	Recommended
<b>All Other Exterior Applications</b>			
Less than 10 ft (3 m) in height above finished grade	Not Recommended	Recommended	Recommended
All other exterior applications	Not Recommended	Not Recommended	Recommended
<b>Special Applications</b>			
Installed directly on cement board	Not Recommended	Not Recommended	Recommended
Non-vertical applications <sup>3,4</sup>	Not Recommended	Not Recommended	Recommended
<sup>1</sup> If the surface area of an AMSV unit exceeds 1 ft <sup>2</sup> (0.1 m <sup>2</sup> ) or 24 in. (610 mm) in any dimension, then install using setting bed mortar complying with ANSI A118.4 or ANSI A118.15. <sup>2</sup> Requires a minimum nominal mortar joint thickness of 1/4 in. (6.4 mm) around AMSV units. <sup>3</sup> Requires a fastening system designed by a professional engineer. <sup>4</sup> AMSV units should not be subjected to pedestrian or vehicular traffic. <sup>5</sup> The scope of ANSI A118.15 references these mortars can be used in submerged locations. It is not recommended to use AMSV in submerged applications or other applications with continuous exposure to water.			

all AMSV systems incorporate mortar between the units, while others allow the distance between units to be varied to create alternative architectural finishes. Recommendations for the pointing mortar are as follows:

- Site Mixed: Meets the requirements of ASTM C270 Type N or Type S
- Preblended: Meets the requirements of ASTM C1714/C1714M Type N or Type S

It is important to note that mortars mixed with higher amounts of cement will tend to be less workable and may be prone to increased shrinkage cracking, but will provide greater bond strength. Type N mortars are generally easier to work with than Type S mortars due to the higher cement content of Type S mortars.

### General Mortar Considerations

When considering mortar selections, verify the mortar can provide a minimum shear bond strength of 50 lb/in.<sup>2</sup> (345 kPa) when tested in accordance with ASTM C482, is consistent with the stone manufacturer's recommendations, and is suitable for installation of adhered manufactured stone veneer. Prepackaged/preblended mortars should be mixed and installed per mortar manufacturer's instructions

In some cases additives or admixtures are added to

mortars to modify one or more plastic or hardened properties of the mortar; such as workability enhancers, water repellents, or bond enhancers. When a modifier is introduced to a mortar comply with ASTM C270 or ASTM C1714, the additional requirements of ASTM C1384 must also be met. Modifiers used in the production of mortar complying with ANSI A118.4 or ANSI A118.15 are specifically designed to increase the mortar's bond strength.

As reflected in Table 2, modified mortars containing bond enhancers and mortars with higher cement contents are better suited for challenging installations or where increased bond strength is desired. Examples of these installations include exterior applications or when directly bonding to substrates such as cement board. As not all mortar admixtures are compatible or interchangeable, consult with mortar or additive manufacturers to ensure compatibility of mortar and admixture components.

## SURFACE PREPARATION

Verify that the surface to which the AMSV is to be installed is structurally sound, free of any coatings or materials that would inhibit bonding, and capable of supporting the intended AMSV system. The majority of the discussion and details in this guide focuses on the

installation of AMSV systems on backup systems consisting of wood or steel framing with rigid sheathing and concrete or concrete masonry construction; however, virtually any backup system can be used when properly designed and prepared to receive AMSV systems.

Masonry walls, poured-in-place concrete walls, and concrete tilt up panels must be free of dirt, waterproofing, paint, form oil, or any other substance that could inhibit the mortar bond and must readily accept/absorb water in order to achieve good bond. The International Concrete Repair Institute, (ICRI), provides guidance for concrete surface preparation and assessment. The surfaces intended to receive AMSV units must have a rough texture to ensure good mortar bond. Refer to ICRI Technical Guideline 310.2 for additional information on concrete surface preparation, including information on Concrete Surface Profile (CSP), a standardized method to measure concrete surface roughness. A CSP equal to or greater than 2 is usually acceptable for the installation of AMSV over concrete and masonry assemblies. If necessary, cleaning may be done with power washing or mechanical methods (i.e. shot or bead blasting). If a bondable surface cannot be achieved, attach lath and scratch coat before installing AMSV. This guide does not address the installation of AMSV systems over open stud backup systems.

### Wall Systems with Exterior Continuous Insulation

AMSV may be installed on walls insulated with continuous insulation such as foam insulation. See Tables 3 and 4 for requirements on fastening over continuous insulation, which are adopted from similar provisions in Chapter 26 of the International Building Code. The requirements are contained within the IBC. The allowable insulation

thicknesses are based upon the fastener type, fastener spacing, cladding weight, and supporting backup system.

### Water Resistive Barrier

Where a water resistive barrier (WRB) is required, it should be installed in two separate layers in shingle fashion, starting from the bottom of the wall. The inner layer of WRB (herein referred to as the Primary WRB) should be installed, along with flashings, to create a drainage plane. The outer layer of WRB (herein referred to as the Secondary WRB) is intended to keep the scratch coat from contacting the Primary WRB. For WRB materials complying with ASTM D226, the upper layer of the WRB should lap on on top of the lower layer by a minimum of 2 inches (51 mm), and the vertical joints should be lapped a minimum of 6 inches (152 mm). Refer to the WRB manufacturer's information for lapping requirements for other WRBs. Inside and outside corners must be overlapped a minimum of 16 inches (406 mm) past the corner in both directions. The WRB should be installed in accordance with the manufacturer's recommendations and be integrated with all flashing accessories, adjacent WRBs, doors, windows, penetrations, and cladding transitions.

Acceptable WRBs:

- No. 15 felt complying with ASTM D226 Type 1.
- ASTM E2556 Type I or II
- Approved equal in accordance with the building code. Other approved materials must be used and installed in accordance with the manufacturer's instructions and as detailed in compliance reports. The following is a non-exhaustive list of additional materials that may be suitable as a WRB if they

**Table 3: Cladding Minimum Fastening Requirements for Direct Attachment of AMSV Over Insulation for Steel Framing<sup>a</sup>**

Cladding Fastener through Foam Sheathing into:	Cladding Fastener Type and Minimum Size <sup>b</sup>	Cladding Fastener Horizontal Spacing ( in. )	Cladding Fastener Vertical Spacing ( in. )	Maximum Thickness of Foam Sheathing <sup>c</sup> ( in. )		
				Cladding System Weight <sup>d</sup>		
				11 psf	18 psf	25 psf
Steel framing (minimum penetration of steel thickness plus 3 threads)	#8 screw into 33 mil steel or thicker	16	6	2.95	2.20	1.45
	#10 screw into 33 mil steel or thicker	16	6	3.50	2.70	1.95
	#10 screw into 43 mil steel or thicker	16	6	4.00	4.00	3.60

For SI: 1 in. = 25.4 mm; 1 pound per square foot (psf) = 0.0479 kPa, 1 pound per square inch = 0.00689 MPa.

DR = design required;

<sup>a</sup> Steel framing shall be minimum 33 ksi steel for 33 mil and 43 mil steel and 50 ksi steel for 54 mil steel or thicker.

<sup>b</sup> Screws shall comply with the requirements of AISI S200.

<sup>c</sup> Foam sheathing shall have a minimum compressive strength of 15 pounds per square inch in accordance with ASTM C578 or ASTM C1289.

<sup>d</sup> Cladding System Weight includes the installed weight of the AMSV units, setting bed mortar, lath, and scratch coat.

**Table 4: Cladding Minimum Fastening Requirements for Direct Attachment of AMSV over Insulation for Wood Framing<sup>a</sup>**

Cladding Fastener through Foam Sheathing into:	Cladding Fastener Type and Minimum Size <sup>b</sup>	Cladding Fastener Horizontal Spacing ( in. )	Cladding Fastener Vertical Spacing ( in. )	Maximum Thickness of Foam Sheathing <sup>c</sup> ( in. )		
				Cladding System Weight <sup>d</sup>		
				11 psf	18 psf	25 psf
Wood framing (minimum 1/4 in. penetration)	0.113 in. diameter nail	16	6	1.45	0.75	DR
	0.120 in. diameter nail	16	6	1.70	0.90	0.55
	0.131 in. diameter nail	16	6	2.15	1.20	0.75
	0.162 in. diameter nail	16	6	3.55	2.05	1.40

For SI: 1 inch = 25.4 mm; 1 pound per square foot (psf) = 0.0479 kPa

DR = design required

<sup>a</sup> Wood framing shall be Spruce-Pine-Fir or any wood species with a specific gravity of 0.42 or greater in accordance with AFPA/NDS.

<sup>b</sup> Nail fasteners shall comply with ASTM F1667, except nail length shall be permitted to exceed ASTM F1667 standard lengths.

<sup>c</sup> Foam sheathing shall have a minimum compressive strength of 15 psi in accordance with ASTM C578 or ASTM C1289.

<sup>d</sup> Cladding System Weight includes the installed weight of the AMSV units, setting bed mortar, lath, and scratch coat.

include documentation of compliance with the referenced acceptance criteria:

- Materials evaluated for compliance with ICC-ES AC38.
- Liquid-applied materials evaluated for compliance with ICC-ES AC212 (for use as Primary WRB only)
- Pre-coated sheathing evaluated for compliance with ICC-ES AC310 (for use as Primary WRB only)
- It is permitted to use only a primary WRB between cement board and the substrate.
- As discussed in the “Rainscreen Drainage Plane Systems”, building codes may allow a single layer of a WRB to be used when a drainage space is incorporated in the wall system. Requirements for the rainscreens vary by region. Verify with the local jurisdictional requirements regarding the use an application of rainscreens. Refer to Figures 35-38 for details on such construction method.
- When transitioning to another cladding (such as that shown in Figure 8), refer to the applicable building code requirements for WRB behind that specific cladding system. Despite the number of layers required for the non-AMSV cladding, there must be two (2) layers of WRB present behind the AMSV.
- Some types of continuous insulation may be substituted for the Primary WRB provided it is installed and sealed and/or taped in accordance with the insulation manufacturer's installation instructions and approved for such applications. Continuous insulation is commonly applied on the exterior side of the framing or

on the exterior side of sheathing, runs continuously, and has minimal thermal bridging. Ensure WRB(s) selected are approved for wall applications. Some WRB's intended for roofs are not appropriate for walls. For example, 15 pound felt is not the same product as No. 15 felt. For details of this practice, please refer to the continuous insulation figures shown throughout the figures section of this guide.

### Lath

The installation of lath should be in accordance with ASTM C1063. Lath should be applied horizontally (perpendicular to framing, if present) per manufacturer's instructions, and should overlap a minimum of 1 in. (25 mm) at the vertical seams and a minimum of 1/2 in. (13 mm) at the horizontal seams. Vertical seams should be staggered. Lath should be wrapped around inside and outside corners a minimum of 12 in. (305 mm). Lath should be fastened every 7 in. (178 mm) vertically on each stud. The spacing of studs should not exceed 16 in. (406 mm). A similar spacing should be used on concrete or masonry wall surfaces, when used. Do not place seams at inside/outside corner framing.

If not installed in accordance with ASTM C1063, alternate lath installation practices should be in accordance with manufacturer's instructions. Acceptable installation practices for metal lath should be evaluated in accordance with AC191 and ASTM C933.

While recommendations vary, existing codes and standards do not stipulate the orientation of the lath “cups” (keys) once installed. More important than the orientation of the lath cups is ensuring the lath is embedded

within, and bonded to, the mortar scratch coat for a successful AMSV installation. Lath is considered to be embedded within the mortar scratch coat when there is a 1/4 in. (6 mm) nominal thickness of mortar between the back plane of the lath and the back plane of the scratch coat for at least one-half (50%) of the surface area of the installation.

Please refer to Figures 1 and 2 for general details on lath installation based on backing.

### **Cement Board**

The installation of cement board should be in accordance with the cement board manufacturer's instructions. Cement board should be fastened every 8 in. (203 mm) vertically on each stud. The spacing of studs should not exceed 16 in. (406 mm). A similar spacing should be used on concrete or masonry wall surfaces, when used.

The seams between cement boards must be treated per manufacturers instructions. For exterior applications, use 4 in. (100 mm) wide alkali-resistant fiberglass mesh tape. For interior applications use 2 in. (50 mm) wide alkali-resistant fiberglass mesh tape. A coat of modified mortar meeting either ANSI A118.4 or ANSI A118.15 must be used to bed the fiberglass mesh tape. The same modified mortar should be applied to corners, control joints, trims or other accessories. Feather modified mortar over fasteners to fully conceal.

### **Flashings/Weep Screeds/Casing Bead/Movement Joints**

All flashing and accessory detailing pieces should be corrosion resistant.

Verify that all flashing, including roofing kickout flashing, has been properly installed. Although roof flashings are not part of the wall cladding system, they are necessary for proper water management. Flashing material should extend above horizontal terminations, roofing material, and drainage planes or drainage products.

All flashing material should be integrated with water resistive barriers to mitigate water penetration into the structure. The WRB should overlap the weep screed flange.

Some applications may not require the use of flashing, weep screeds, and casing beads to prevent water penetration. In cases where there is no WRB present, a weep screed is usually not required but a weep screed or casing bead can still be used for aesthetic purposes. In cases where a drip edge is needed based on a cladding transition, then flashing is required. The use of both flashing and a weep screed simultaneously is not typically necessary.

Plan ahead with the various trades to integrate flashing and water resistive barriers to effectively shed water down and out of the wall system. This may require the preceding trade on the job to install flashing or WRBs for integration with the next trade on the job.

Movement Joints - Different elements and materials within any structure move differently in response to applied loads or as a result of fluctuations in temperature or moisture content. In determining if and where movement joints may be needed as part of an AMSV installation, consideration should be given to where differential movement is expected—for example, at the intersection of dissimilar materials; or where movement may be concentrated—for example, at the transition between a framed backup assembly and a concrete masonry assembly. Additional information is available on the NCMA website: [www.ncma.org](http://www.ncma.org).

### **Clearances**

On exterior frame walls, weep screeds and other base flashings should be held a minimum of 4 in. (102 mm) above grade or a minimum of 2 in. (51 mm) above paved surfaces. This minimum can be reduced to 1/2 in. (13 mm) if the paved surface is a walking surface supported by the same foundation that supports the wall. See Figure 5.

Where the backing is concrete or masonry, maintain 2 in. (51 mm) clearance from grade or 1/2 in. (13 mm) from a paved surface provided that frost heave of adjacent surfaces is taken into consideration.

### **Interior Applications**

Interior applications in non-wet locations (areas not exposed to water) for AMSV are similar to exterior applications with the following alternatives:

- Two layers of WRB are not necessary behind the lath and scratch coat. A single layer of WRB is recommended protect moisture sensitive materials during AMSV installation.
- Interior applications are not subjected to the same fluctuations in temperature and moisture as exterior applications. As such, the criteria for clearances used for exterior applications are typically not necessary. Nevertheless, differential movement between different materials must still be accounted for.
- Flashings, weep screeds, and casing beads are not necessary.

## **INSTALLATION OF ADHERED MANUFACTURED STONE VENEER**

Prior to commencing installation of AMSV, ensure the WRB and flashing are properly installed and integrated.

Refer to the flashing details, referenced in this guide, for detailing around windows, doors, through-wall penetrations, and AMSV terminations.

After the lath is installed, apply a nominal 1/2 in. (13 mm) thick layer of mortar ensuring the lath is completely encapsulated with mortar. The mortar should be applied with sufficient pressure and thickness to fully embed the lath in mortar. Once the mortar is thumbprint hard, scratch (score) the surface horizontally to create the mortar scratch coat.

Moist curing the mortar scratch coat will help reduce cracking and ensure proper hydration during curing. Before applying AMSV, the mortar scratch coat should be dampened so that the surface appears wet but free of standing water.

Before installing AMSV, lay out a minimum of 25 sq ft (2.3 m<sup>2</sup>) of AMSV units at the jobsite so there is a variety of sizes, shapes, and colors from which to choose. Mixing AMSV sizes, shapes, textures and color will allow for variety and contrast in the design to achieve the desirable finished project. Follow AMSV manufacturers recommendations regarding mixing of product to achieve desired results.

The following guidance for grouted and tight-fit application of adhered masonry veneer applies to conventional Type N and Type S mortars. If a modified mortar is used, some of the working properties and installation techniques may vary from those of conventional Type N or Type S mortars. Consult the mortar manufacturer for guidance and instructions. For typical details of AMSV systems, please refer to Figures 1-5.

### **Grouted Adhered Manufactured Stone Veneer Application**

**Tip:** Installing AMSV from the top down will minimize cleanup requirements.

Prior to the application of mortar to the scratch coat or the back of the AMSV, the scratch coat and back of the AMSV should be moistened so that the surfaces appear damp but are free of standing water.

The back of each AMSV should be entirely buttered with mortar to a nominal thickness of 1/2 in. (13 mm). Cover the entire back of the AMSV, not just the perimeter. Buttered AMSV should be firmly worked onto the scratch coat and slid slightly back and forth or with a slight rotating motion to set the AMSV. Modified mortars, complying with ANSI A118.4 or ANSI A118.15, may have a different "feel" than non-modified mortars.

Achieve mortar squeeze out in a volume that results in a full setting bed covering the scratch coat completely. As an alternative to the back-butter only method, mortar may be troweled onto the scratch coat, completely covering the scratch coat. Or, both mortar application

techniques may be combined. The resulting thickness of the scratch coat and setting bed should be nominally 1 in. (25 mm) measured from the outer surface of the WRB to the back surface of the unit.

With the proper mortar mix, moisture content, and scratch coat preparation, the installer will feel the mortar start to grab within a few seconds of the setting movement process. At this point, no further movement of the unit should be made as the bond will be broken. If the AMSV is inadvertently moved after initial set has begun, it should be removed, mortar scraped off the back of the AMSV and scratch coat, and then reinstalled following the application process.

Grouting the joints should be completed only after there is sufficient cure time of the installed AMSV units; when mild contact with AMSV units will not break the bond to the backup system. Grouting may be done with a grout bag, filling joints to the desired depth, ensuring that mortar is forced into all voids. Grout should be "thumbprint hard" before tooling the joints. The curing time required before the grout is ready will vary significantly with temperature and humidity. Use a wooden raking stick or pointing tool to tool the joints to the desired depth. Extra precaution should be taken while tooling so the surface of the AMSV is not damaged. Clean off remaining grout debris on the AMSV surface with a dry, soft-bristled brush.

To prevent mortar smearing, DO NOT use a wet brush to treat uncured mortar joints.

### **Tight Fitted Adhered Manufactured Stone Veneer Application**

Refer to Mortar section for additional guidance regarding mortar selection. For this installation technique, refer to the General Mortar Considerations section.

The back of the AMSV and the scratch coat should be moistened with the surfaces appearing damp but free of standing water.

The back of each AMSV should be entirely buttered with mortar to a nominal thickness of 1/2 in. (13 mm). Cover the entire back of the AMSV, not just the perimeter. Buttered AMSV should be firmly worked onto the scratch coat and slid slightly back and forth to set the AMSV.

Achieve mortar squeeze out in a volume that results in a full setting bed which covers the scratch coat completely. As an alternative to the back-butter only method, mortar may be troweled onto the scratch coat, completely covering the scratch coat. Or, both mortar application techniques may be combined. The resulting thickness of the scratch coat and setting bed should be nominally 1 in. (25 mm) measured from the outer surface of the WRB to the back surface of the unit.



With the proper mortar mix, moisture content and scratch coat preparation, the installer will feel the mortar start to grab within a few seconds of the setting movement process. At this point, no further movement of that AMSV should be made as the bond will be broken. If the AMSV is inadvertently moved after initial set has begun, it should be removed, mortar scraped off the back of the AMSV and scratch coat, and then reinstalled following the application process.

Tight fitted AMSV should be applied from the corners toward the middle of a wall, and from the bottom toward the top of the wall.

### **Cold Weather Application**

AMSV applications should be protected from temperatures below 40°F (4°C) during and immediately following installation. The use of anti-freeze admixtures to lower the freezing point of the mortar is not recommended. Accelerating admixtures shall comply with ASTM C1384; accelerating admixtures containing calcium chloride are not permitted. AMSV pieces containing visible frozen moisture shall not be installed.

The cold weather practices defined in TMS 602 should be followed for the installation of AMSV systems.

### **Hot Weather Application**

If the environmental conditions during installation exceed 90°F (32°C) additional water may be needed on the scratch coat surface and the backs of the AMSV being installed. Providing shade and/or frequent misting of the wall may be required. Consult with mortar manufacturer to determine if hot weather mortar mix options are available. The hot weather practices defined in TMS 602 should be followed for the installation of AMSV systems.

### **Cleaning the Adhered Manufactured Stone Veneer**

Refer to AMSV manufacturer recommendations on cleaning and maintenance. Do not use harsh chemicals for cleaning, such as acid, or use abrasive tools such as wire brushes or power washers.

### **Coating Adhered Manufactured Stone Veneer**

Refer to the AMSV manufacturer for recommendations regarding the use of repellent, sealers, or other topically applied coatings used for water penetration resistance, graffiti resistance, or surface sealing.

### **Alternative Installation Methods/Materials**

This guide covers common installation practices for AMSV systems. Alternative installation materials and

methods not included in this guide may be introduced into the marketplace. Example: Exterior installation methods using cementitious adhesive mortars with a direct application to a substrate that may include coatings applied as loadbearing bonded water-proof membranes.

Alternative installation materials and methods along with their test methods and evaluation criteria are being developed. As a designer, contractor, or installer, you may wish to utilize these materials and/or methods in lieu of the recommended methods included in this guide. Users should verify that the alternative method(s) will meet or exceed the recommended installation practices presented in this guide.

Refer to manufacturer's recommendations for additional information regarding the use of alternative installation methods or materials.

## **CAUTIONS**

The following precautions should be taken to ensure a successful and durable AMSV installation.

- Do not subject AMSV to direct or frequent water contact. Examples include avoiding sprinklers directly spraying on surfaces, pools, and Jacuzzis. Also, downspouts or drainage pipes should be placed so that water is not frequently moistening the AMSV units.
- Do not subject AMSV to contact with de-icing materials, salt, cleaning chemicals, pool chemicals, or other harsh chemicals. Prolonged exposure to these conditions may discolor the AMSV or result in surface damage.
- The installation of AMSV over open stud construction (no sheathing) is not covered in this Guide. Refer to recommendations from the AMSV manufacturer.
- Retaining Walls—the details in this Guide only cover installation of AMSV on retaining walls and required waterproofing for the soil side of the wall (Figure 39). Other details of construction of retaining walls, including water management behind the wall, are outside the scope of this Guide.
- Do not use AMSV on exterior stair risers (or similar situations) where exposure to de-icing chemicals, snow and ice removal tools, where standing water is likely to occur, or when appropriate clearances cannot be maintained.
- Do not use AMSV in applications with potential exposure in direct flame such as return into a firebox of a wood or gas-burning fireplace.

Figure 1. Installation Over Wood Framing

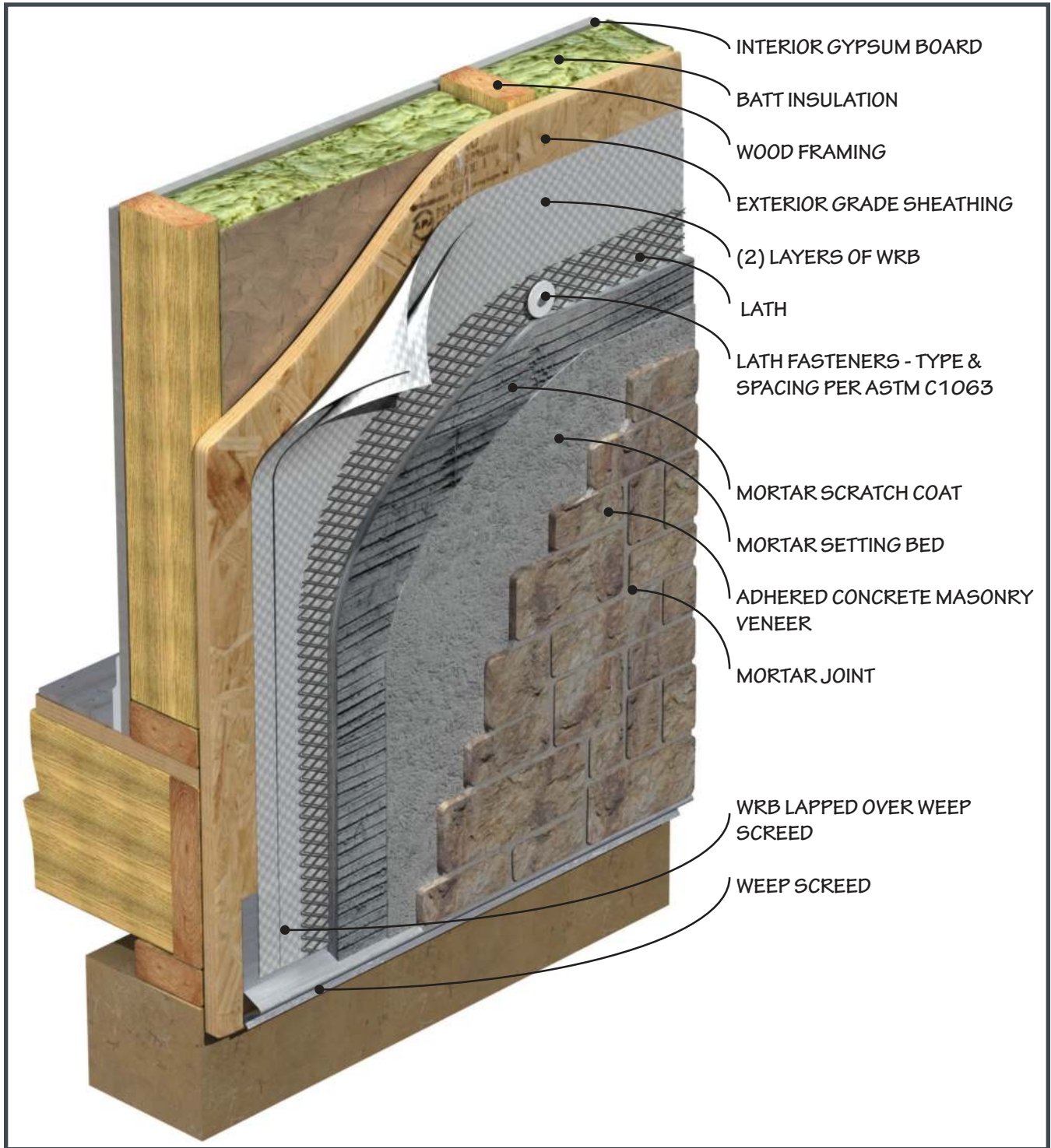
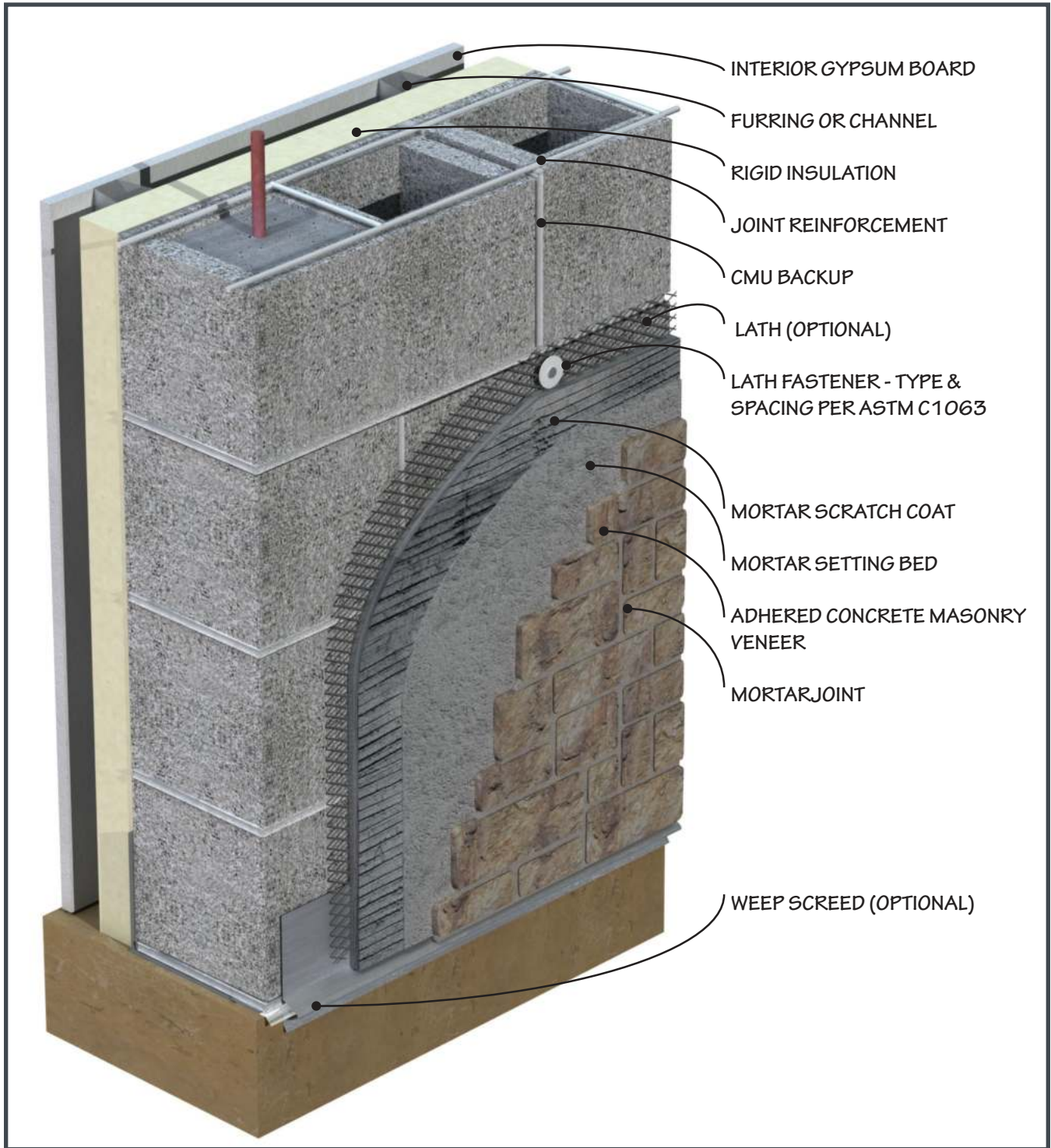
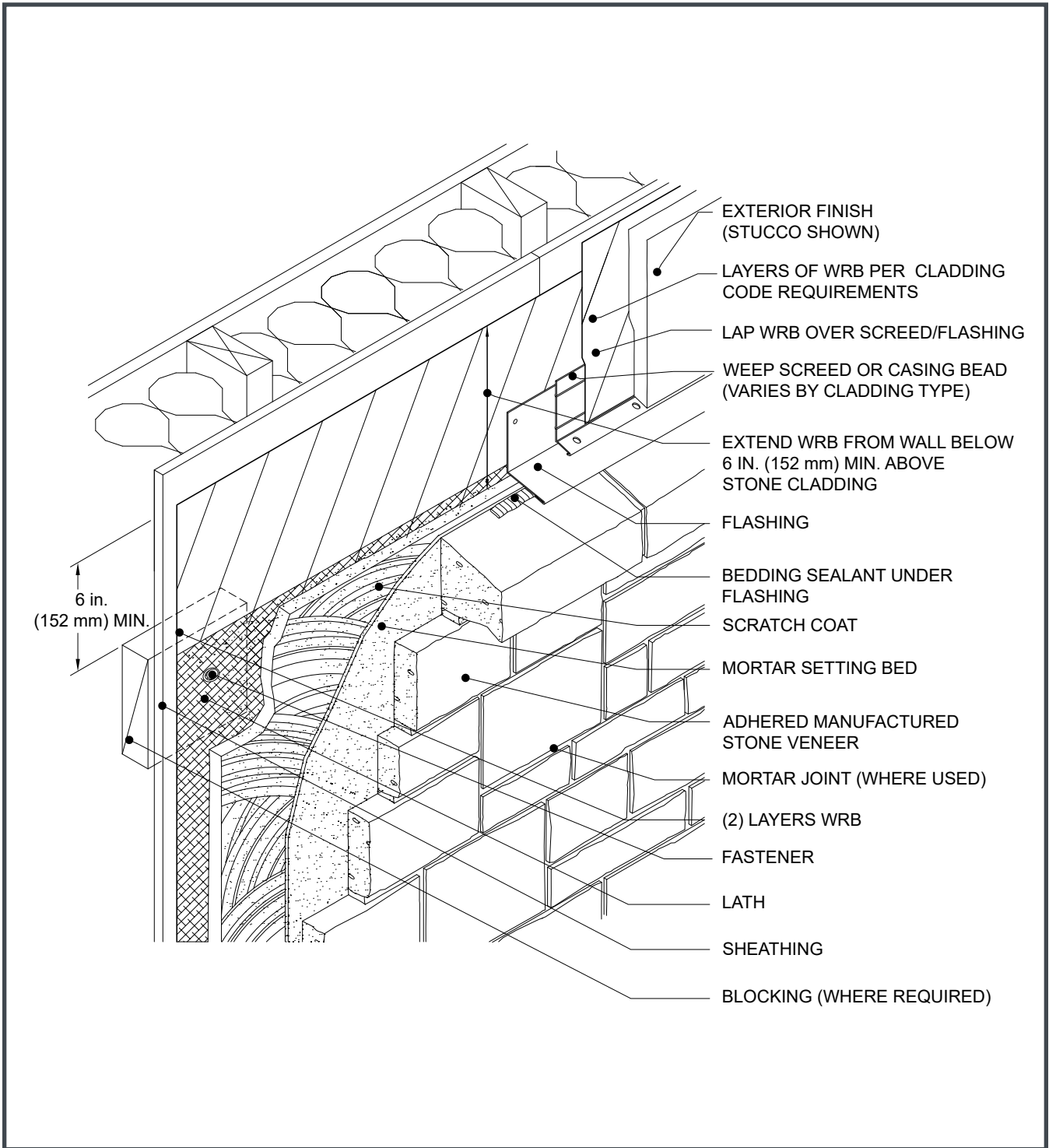


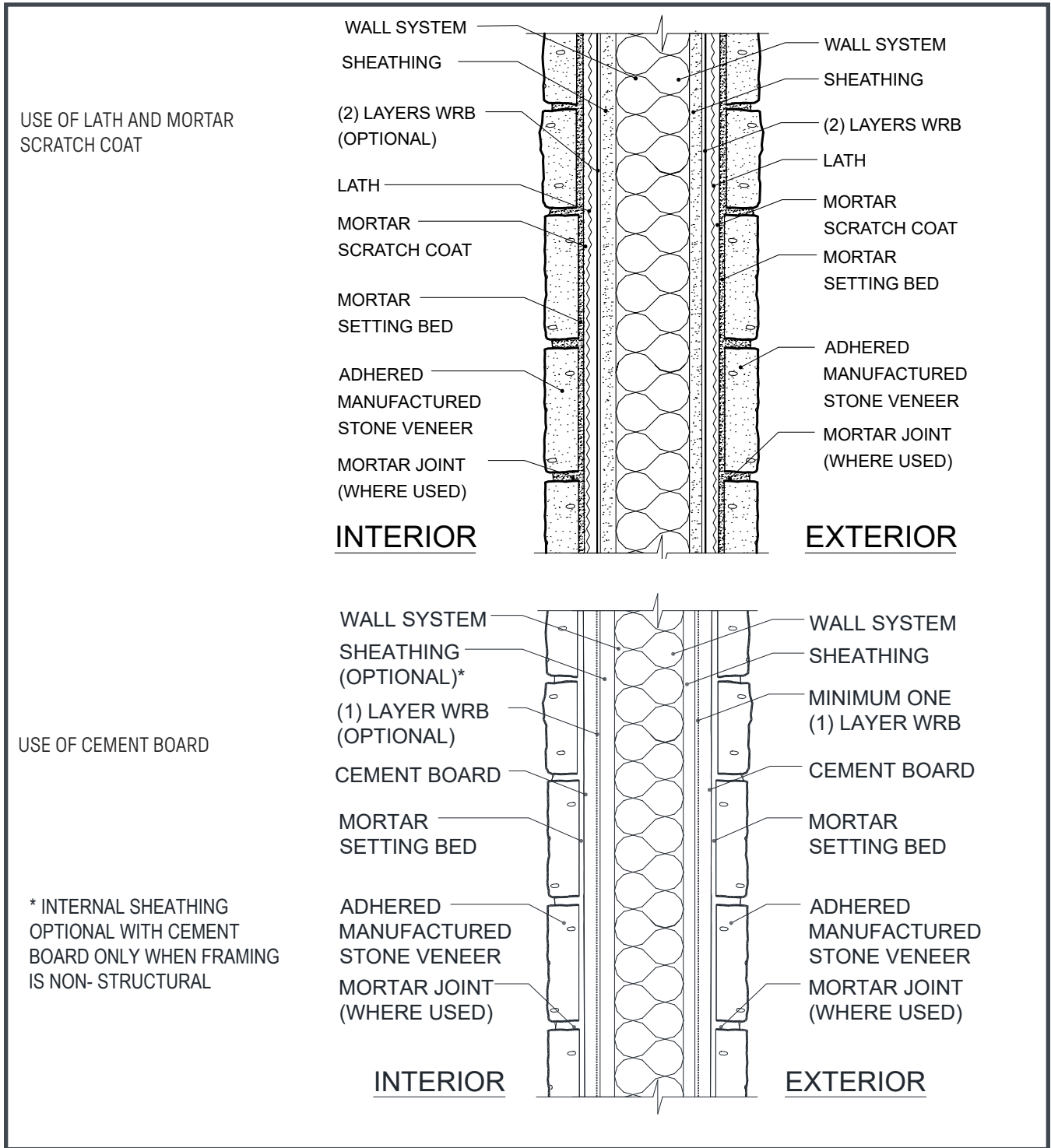
Figure 2. Installation Over Concrete Masonry Units



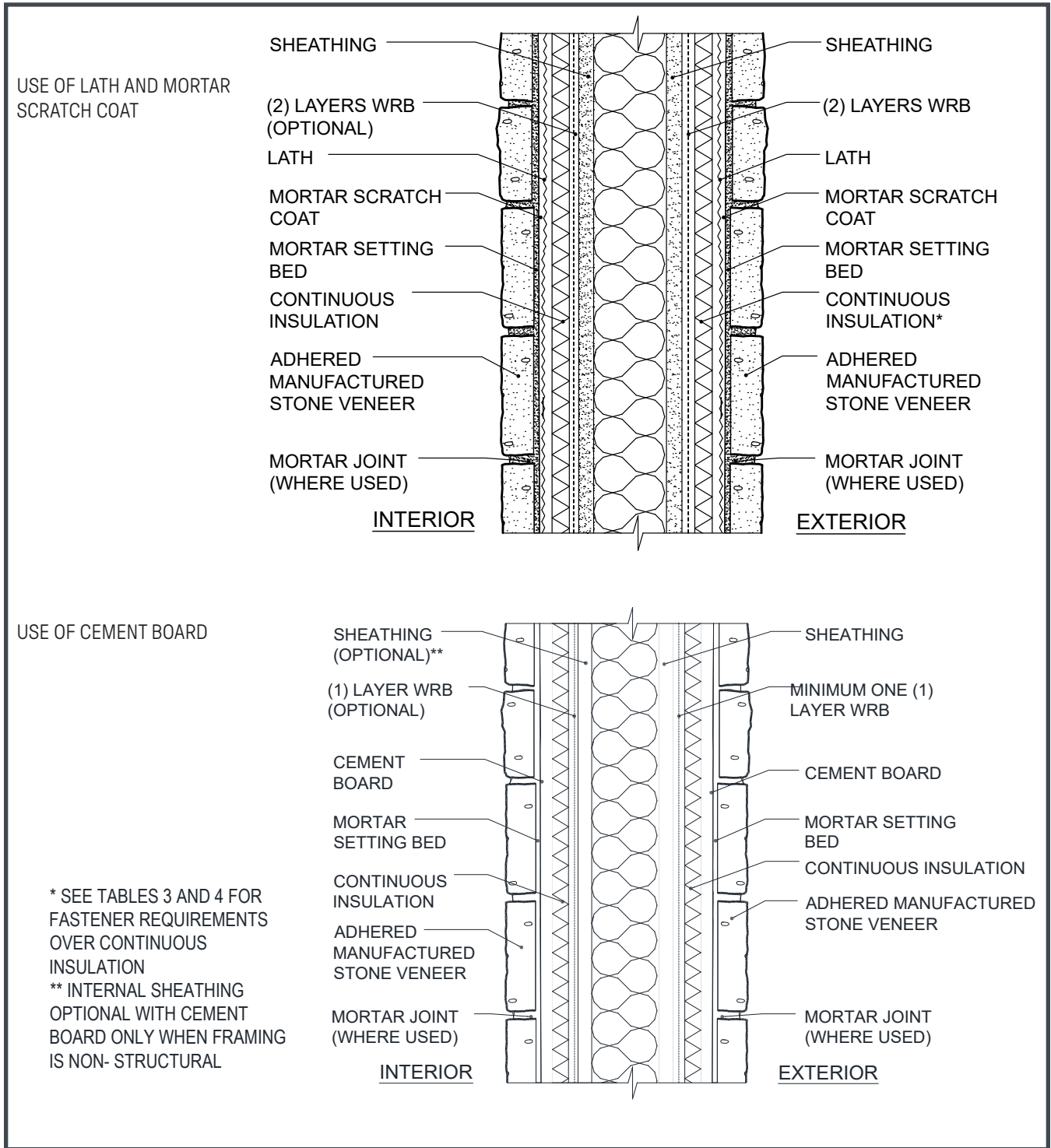
**Figure 3. Wall Assembly Transition**



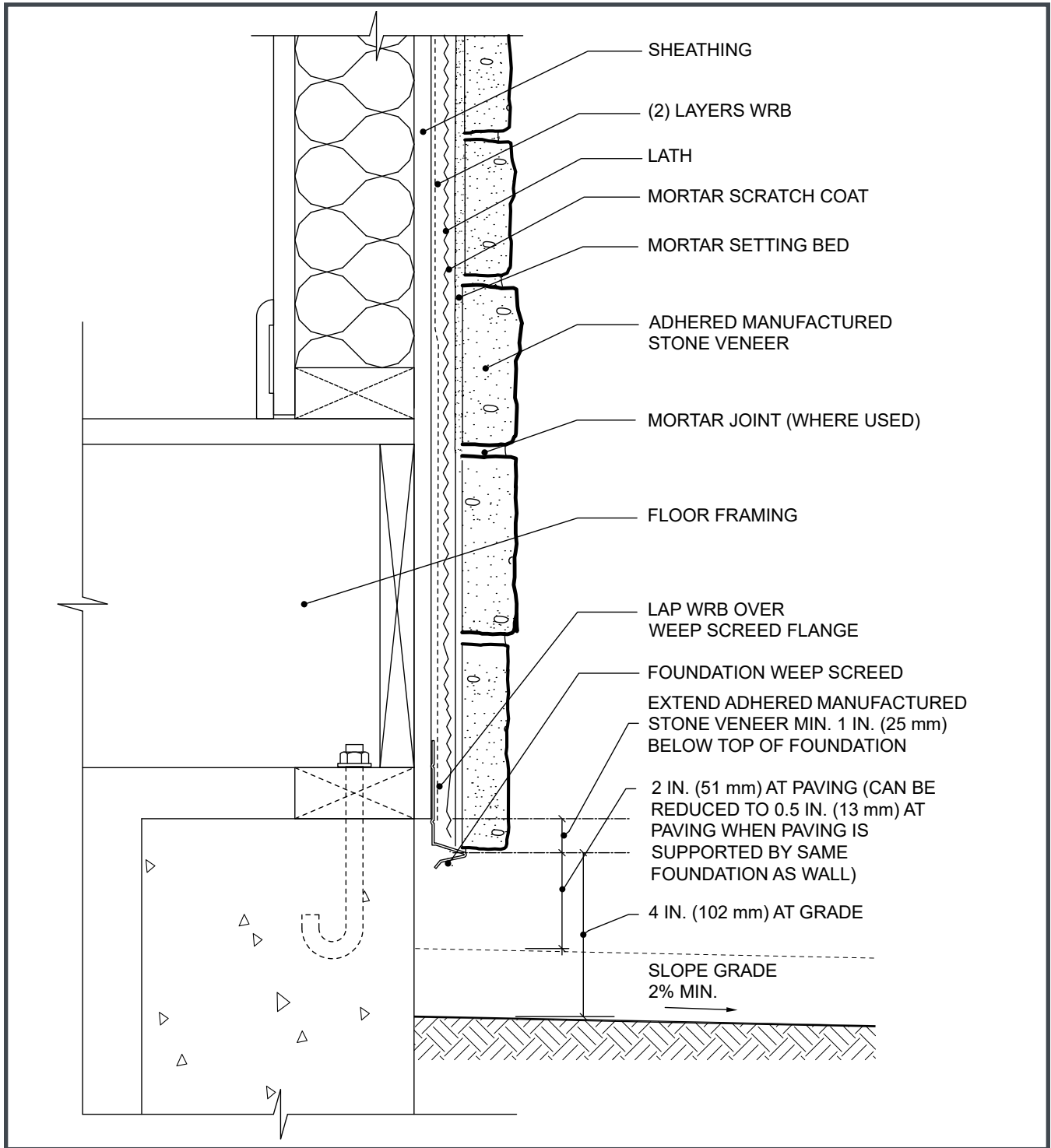
**Figure 4a. Typical Frame Wall Section**



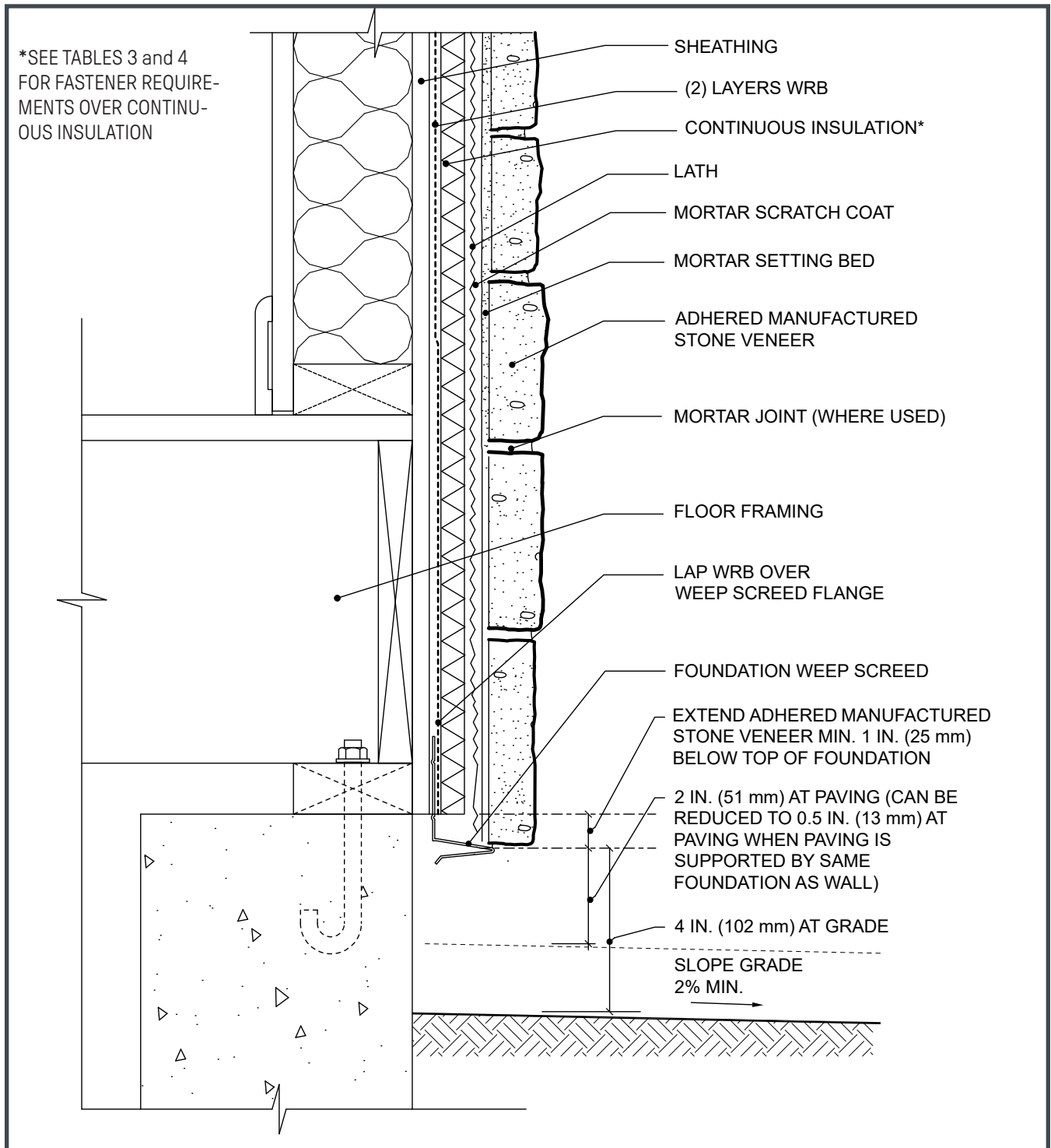
**Figure 4b. Typical Wall Frame Section with Continuous Rigid Insulation**



**Figure 5a. Foundation Wall Base**

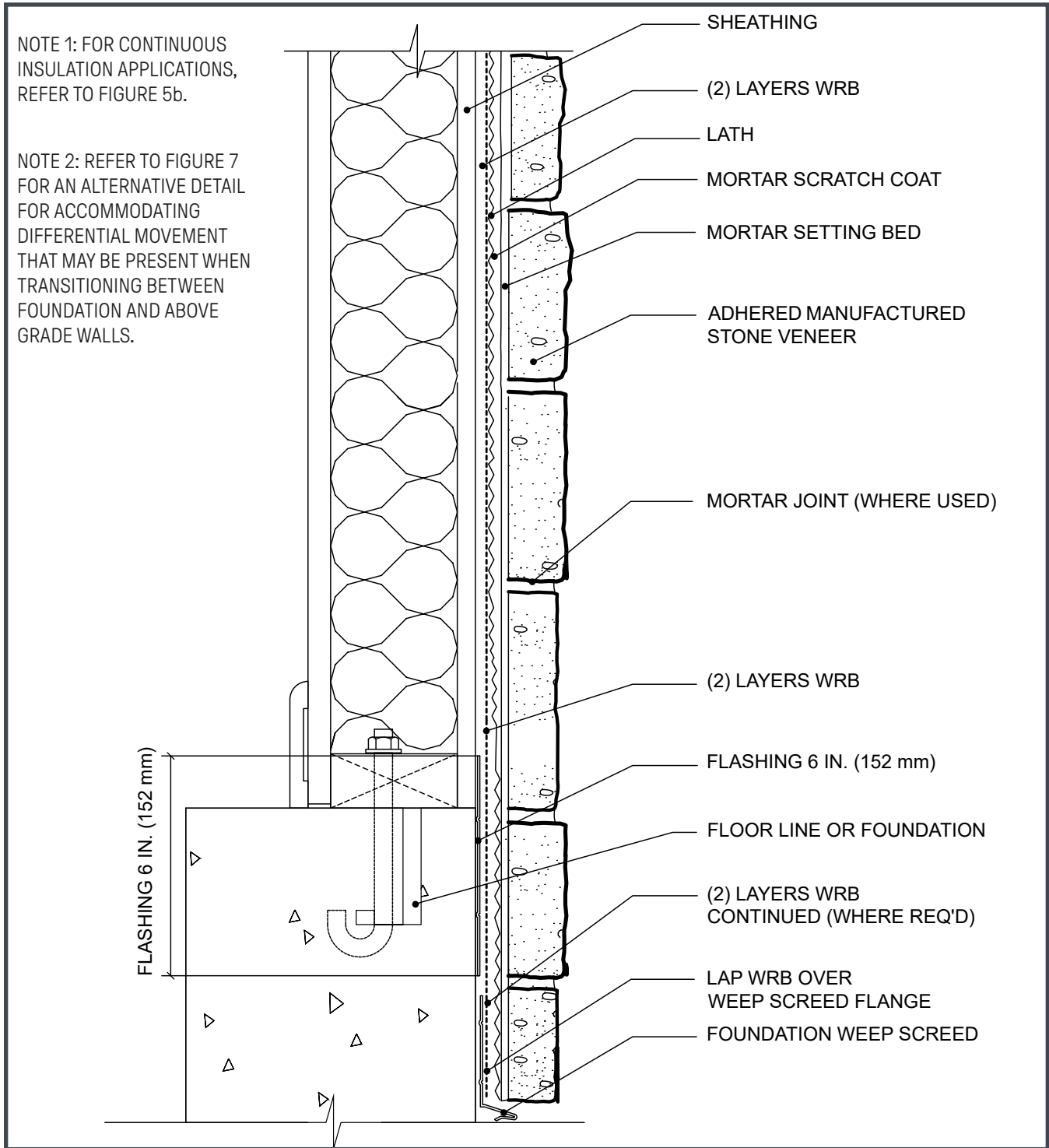


**Figure 5b. Foundation Wall Base Over Continuous Rigid Insulation**

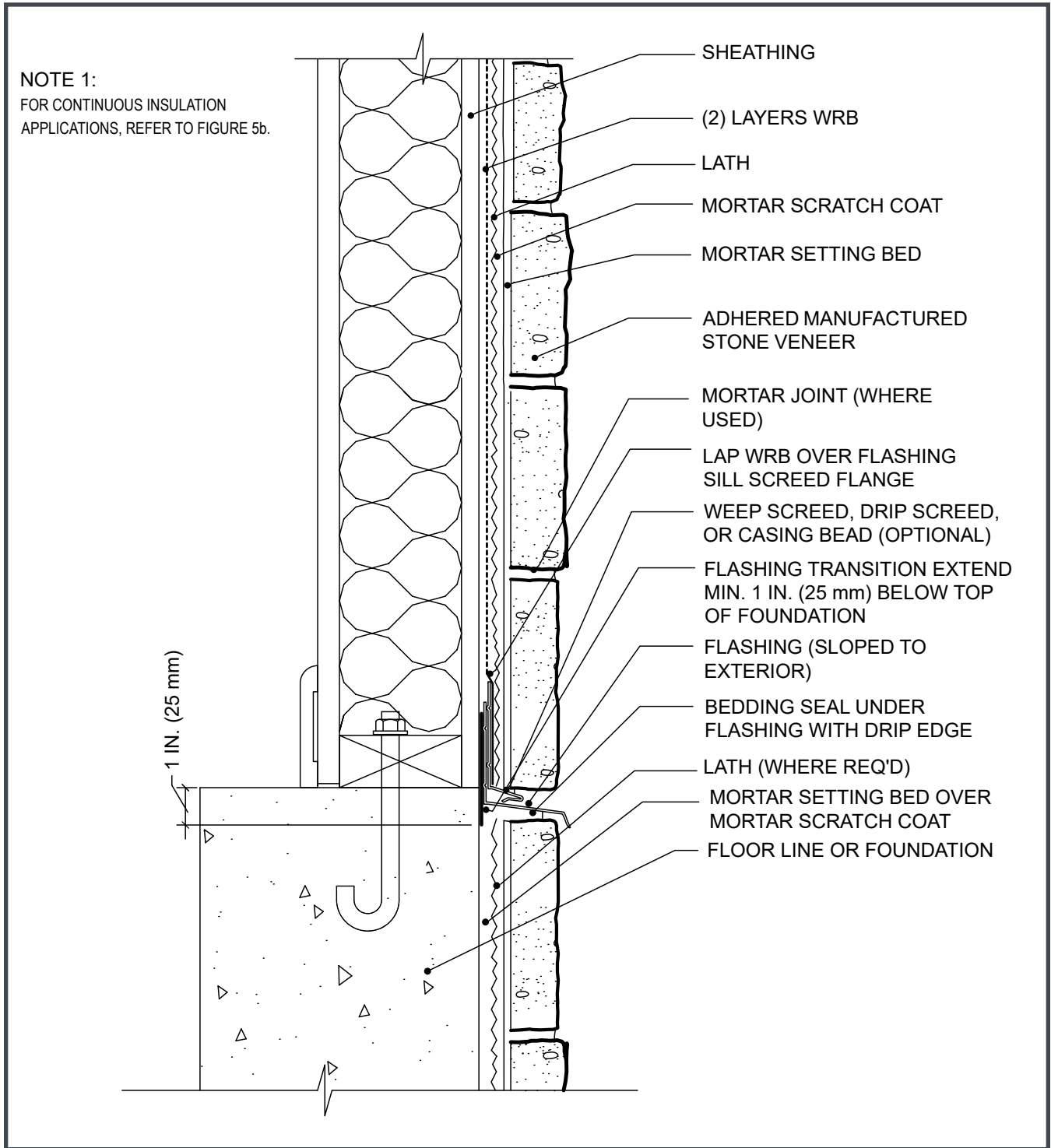




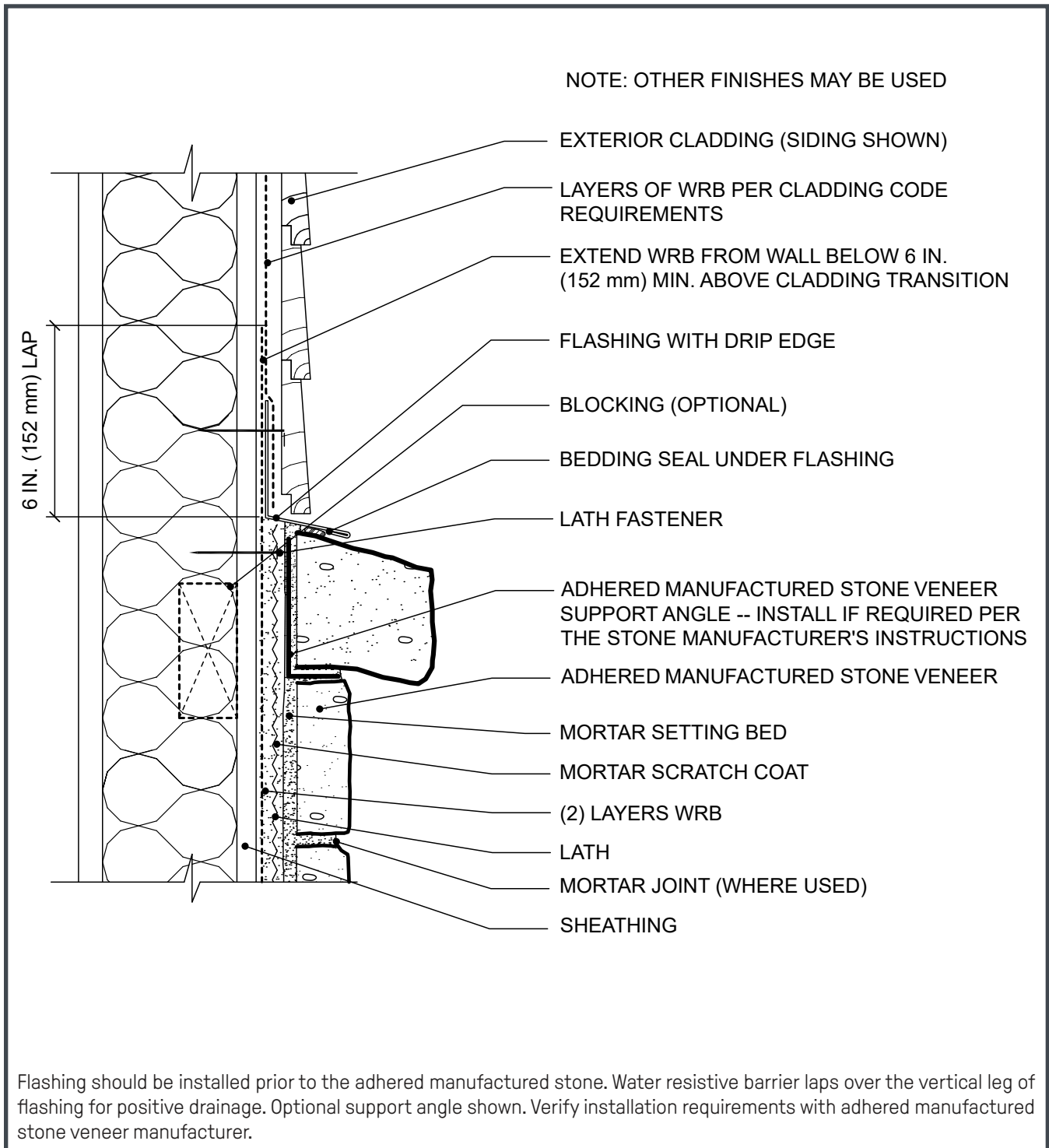
**Figure 6. Foundation Wall Base - AMSV Overlapping Foundation**



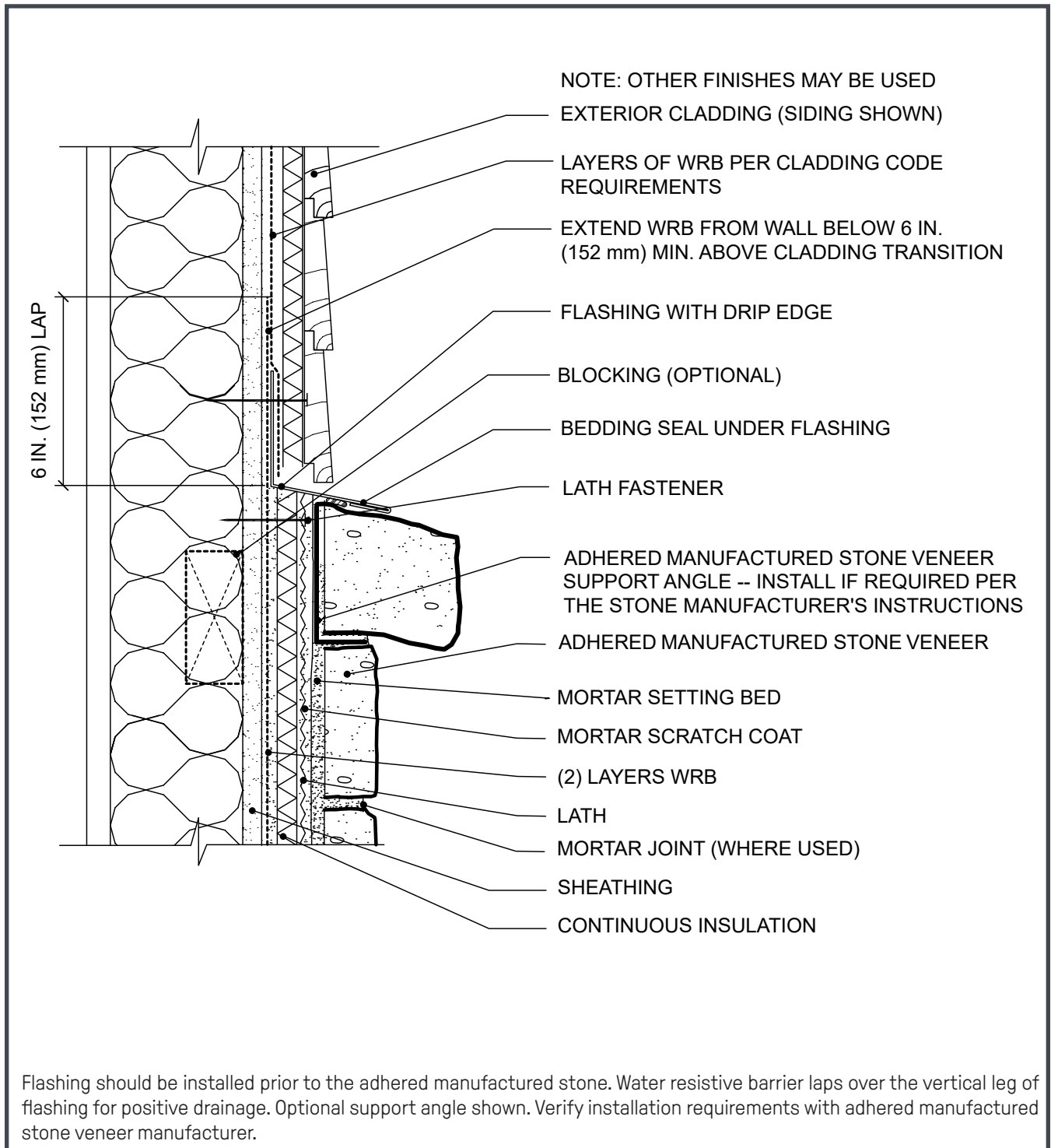
**Figure 7. Foundation Wall - Transition to AMSV Continuing Down Foundation**



**Figure 8a. Cladding Transition**



**Figure 8b. Cladding Transition Over Continuous Rigid Insulation**



Flashing should be installed prior to the adhered manufactured stone. Water resistive barrier laps over the vertical leg of flashing for positive drainage. Optional support angle shown. Verify installation requirements with adhered manufactured stone veneer manufacturer.

Figure 9a. Outside Corner

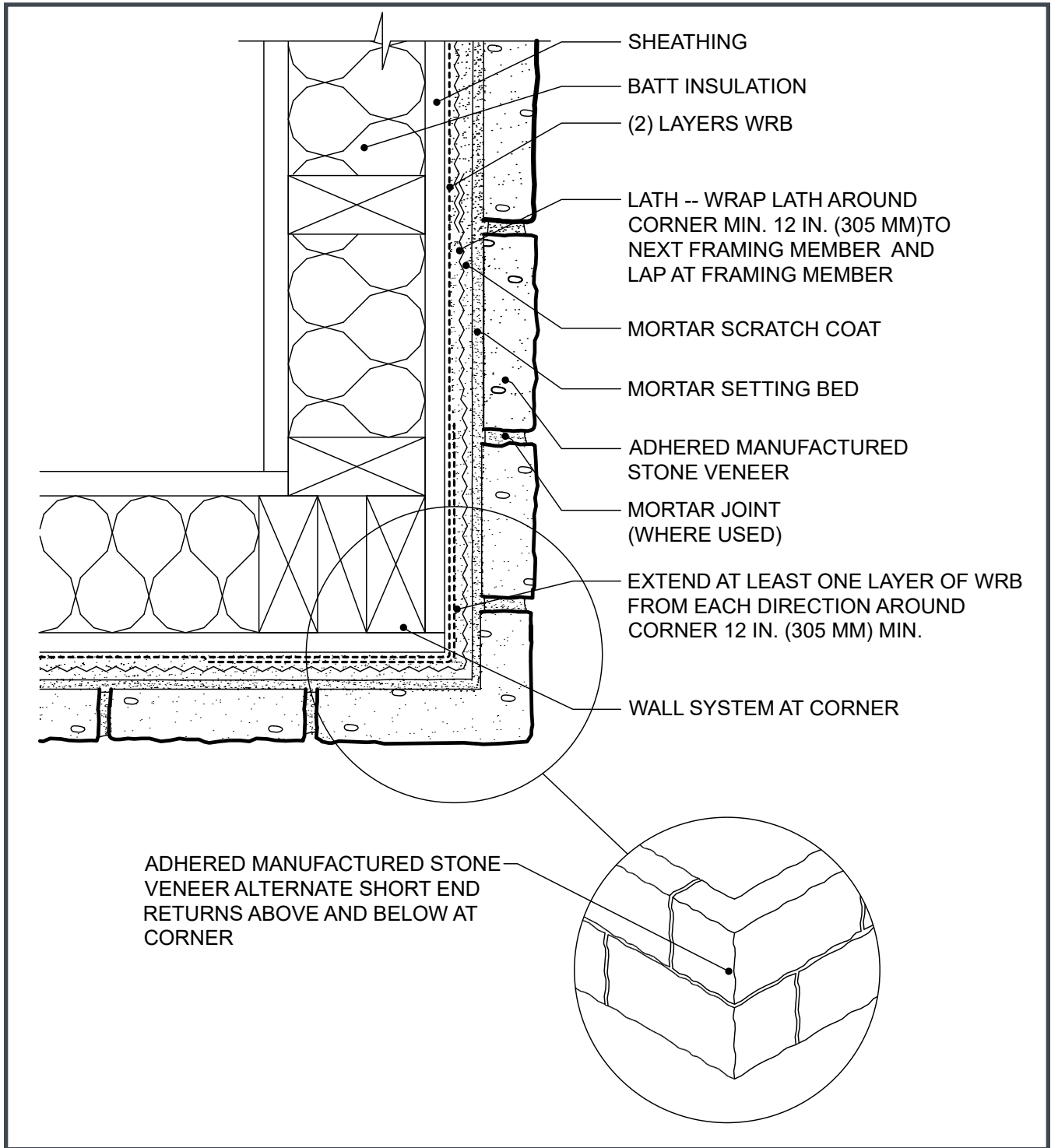


Figure 9b. Outside Corner Over Continuous Insulation

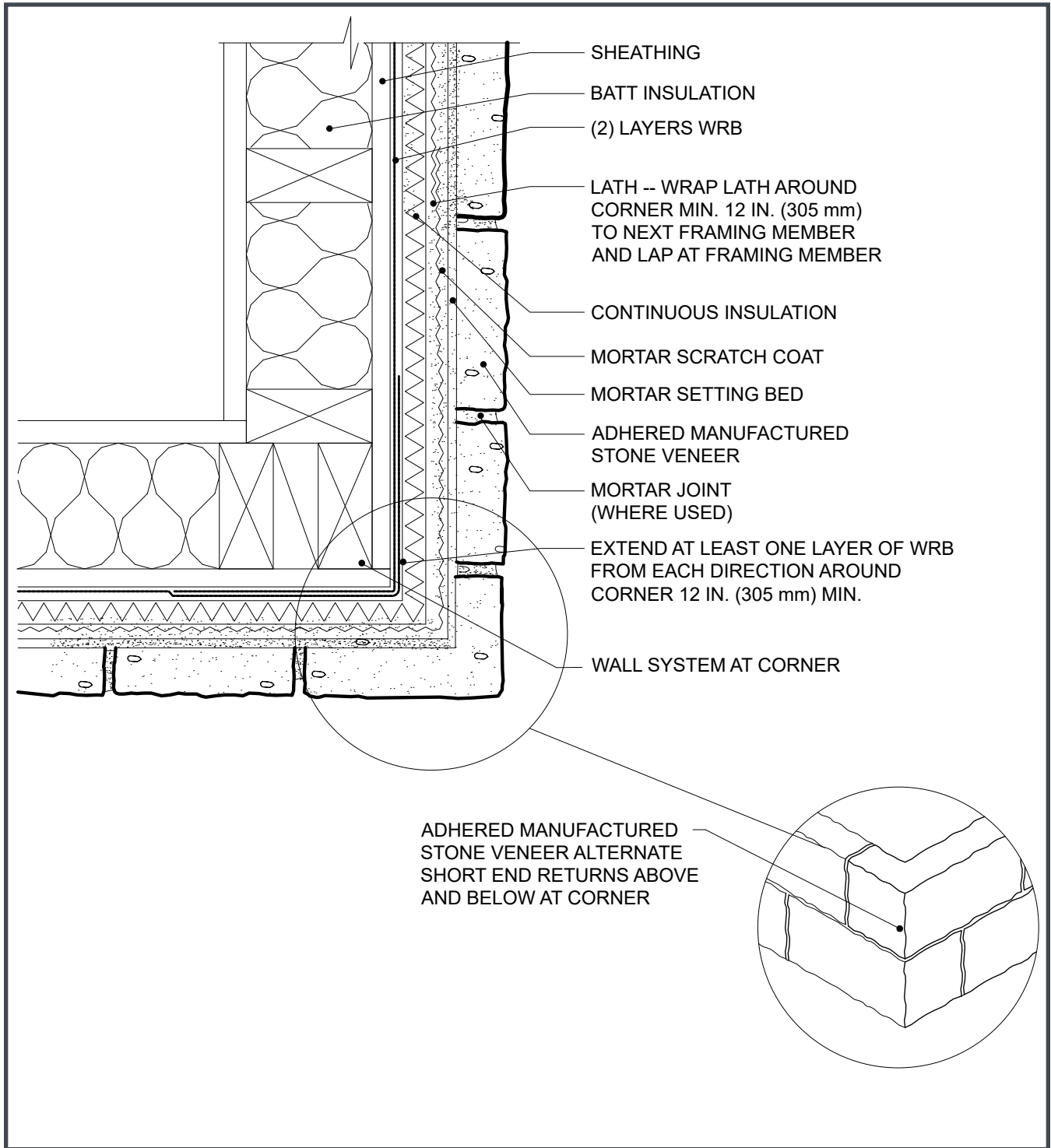


Figure 10a. Inside Corner

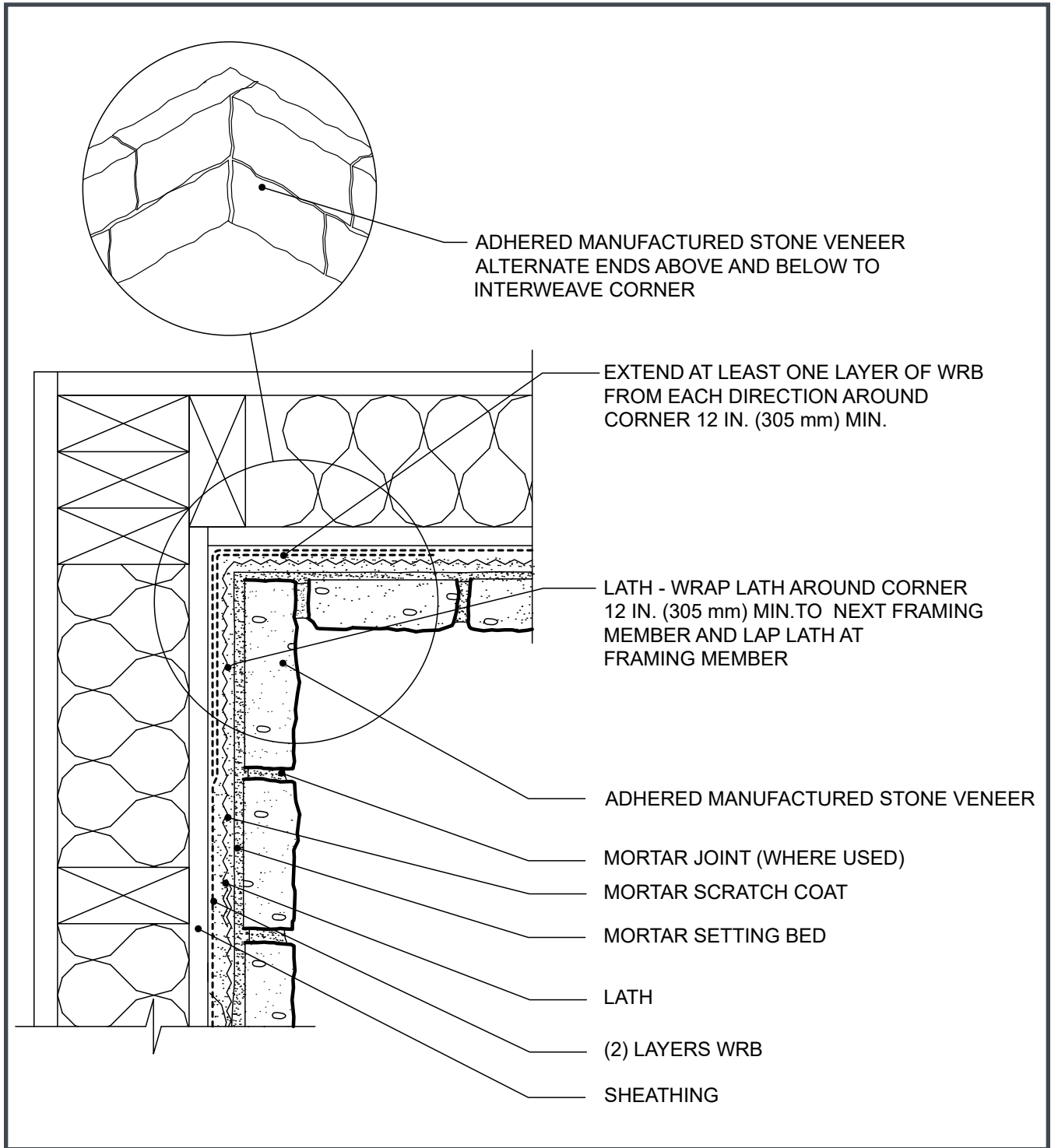
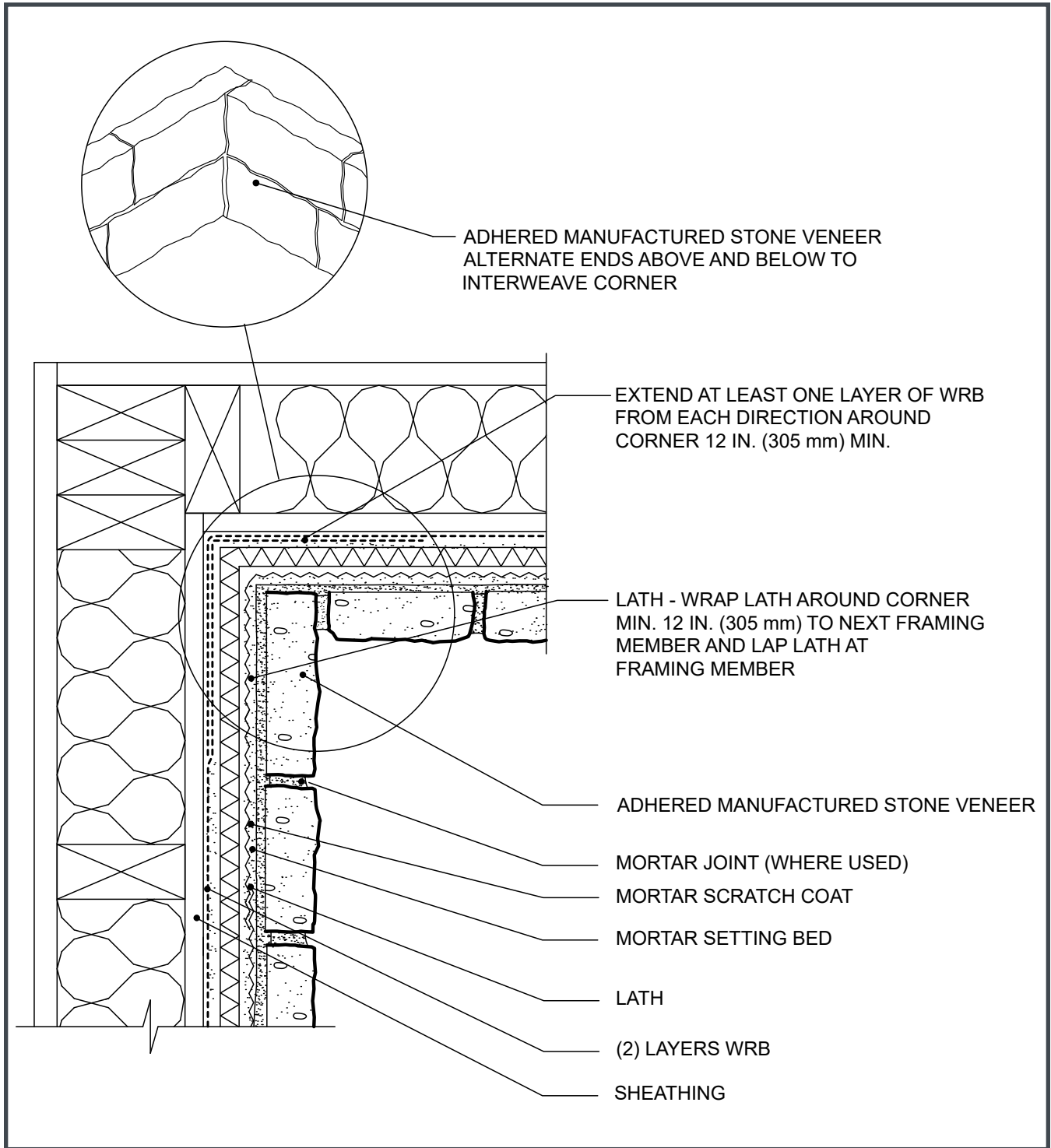
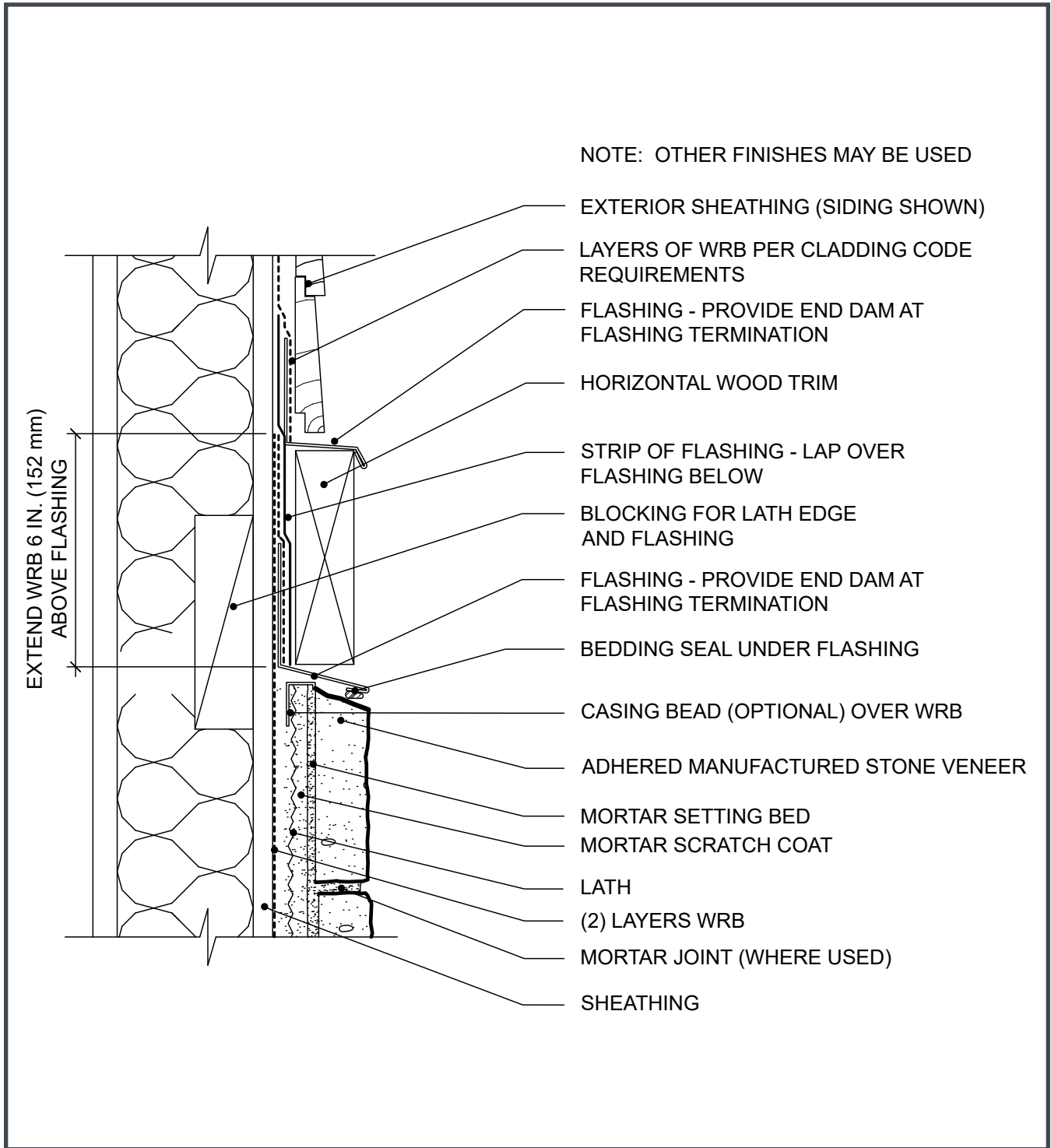


Figure 10b. Inside Corner Over Continuous Insulation





**Figure 11a. Horizontal Transition**



**Figure 11b. Horizontal Transition Over Continuous Insulation**

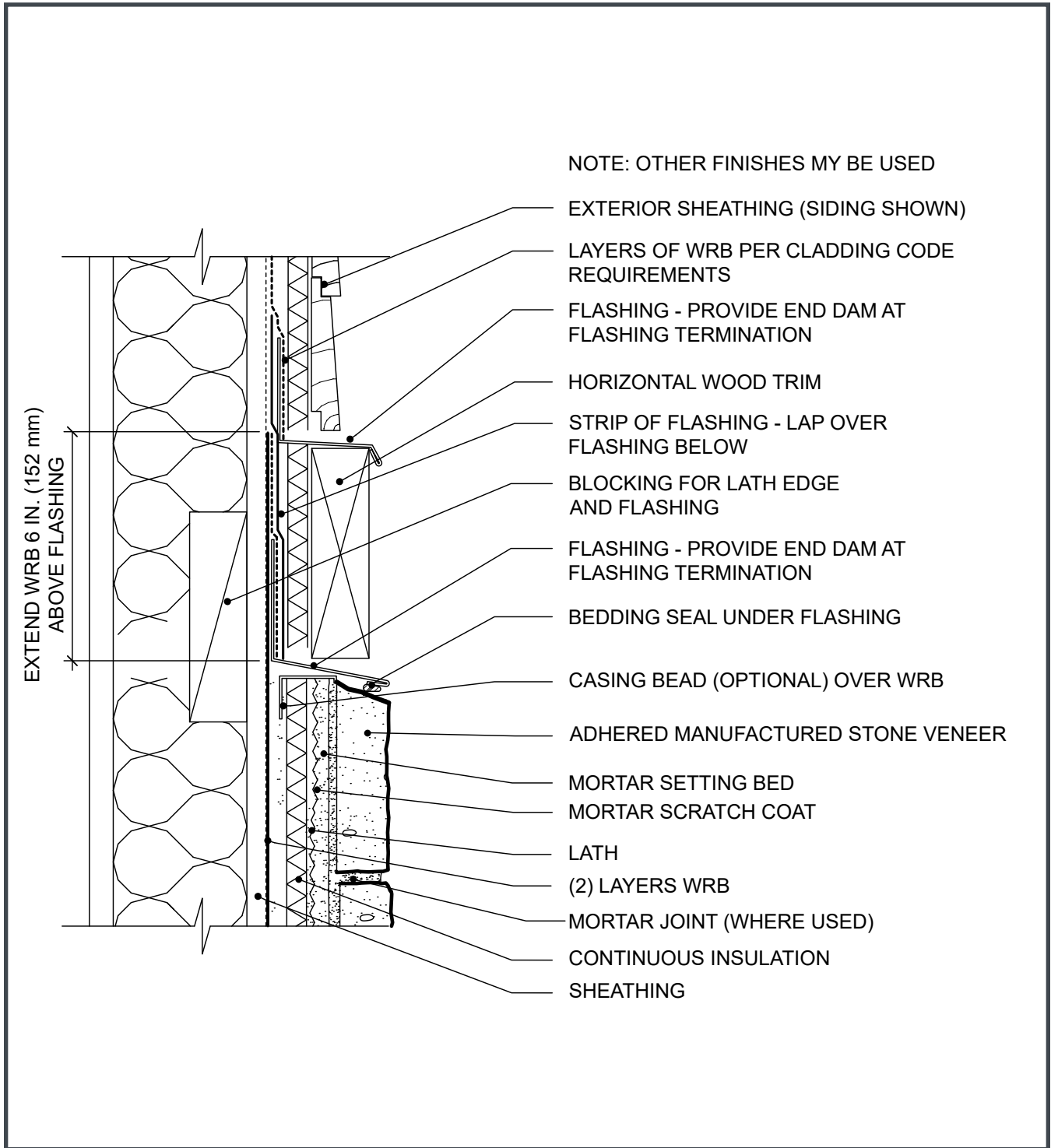


Figure 12a. Vertical Transition

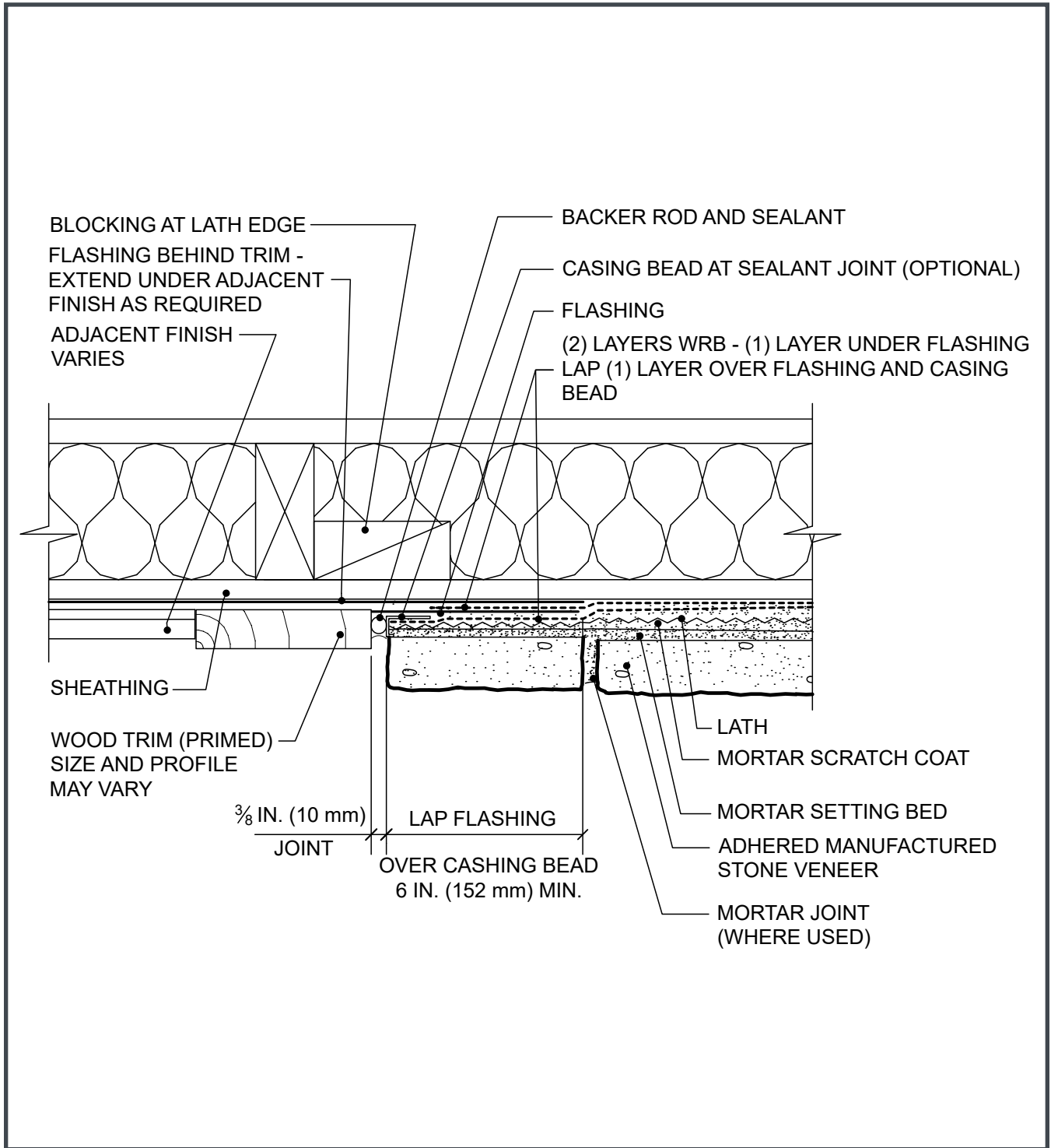


Figure 12b. Vertical Transition Over Continuous Insulation

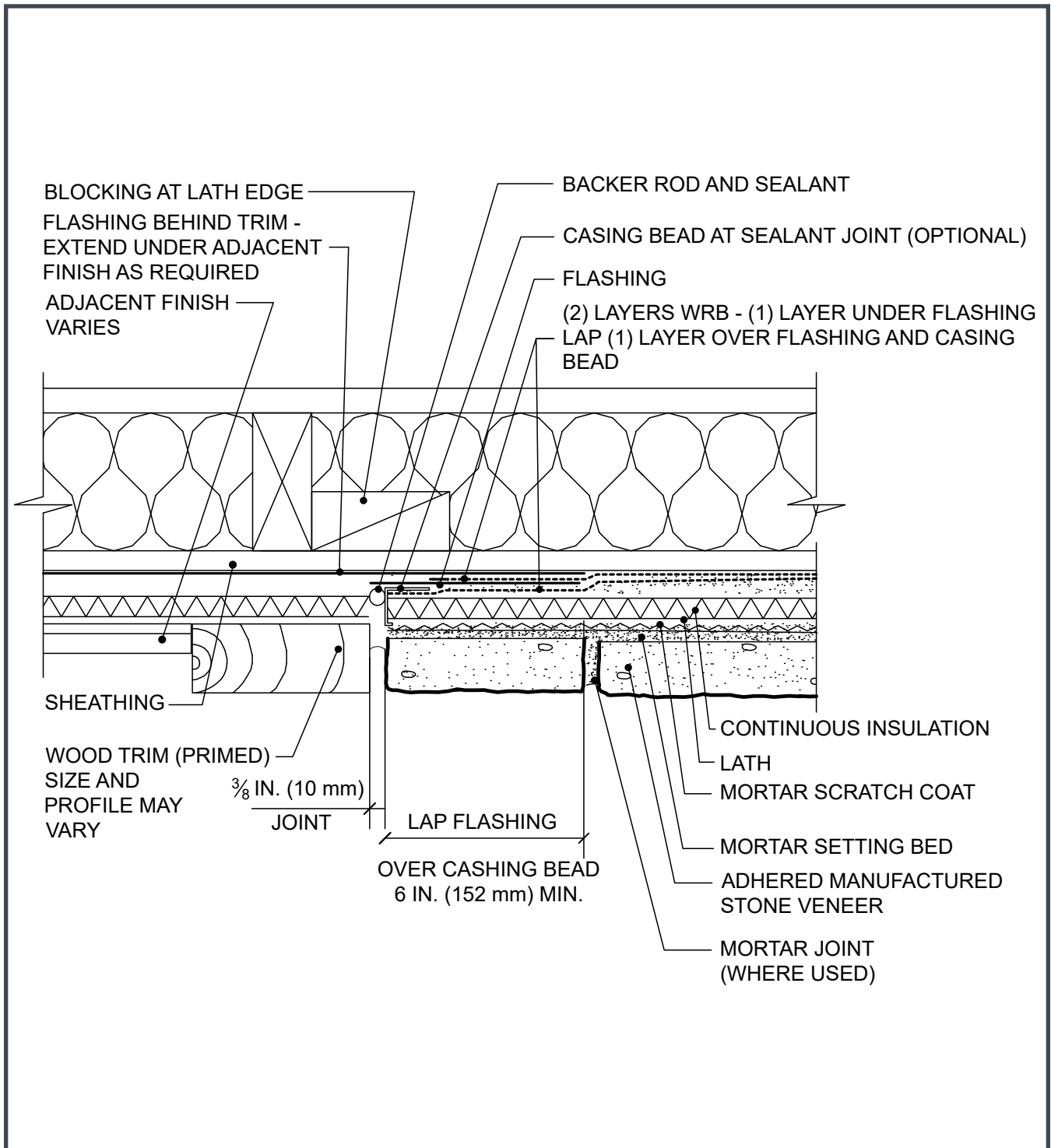


Figure 13a. Open Eave - Overhang

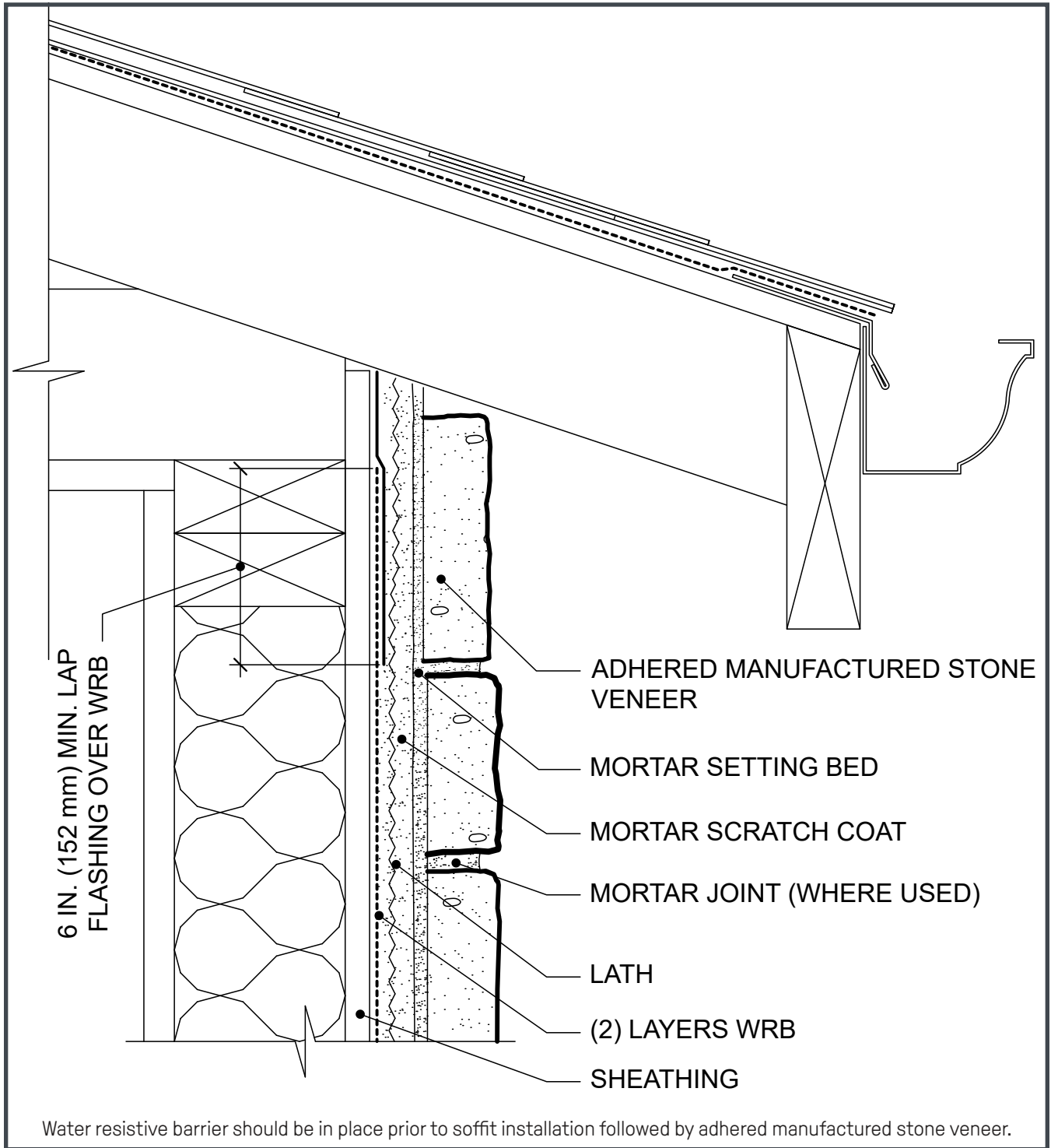
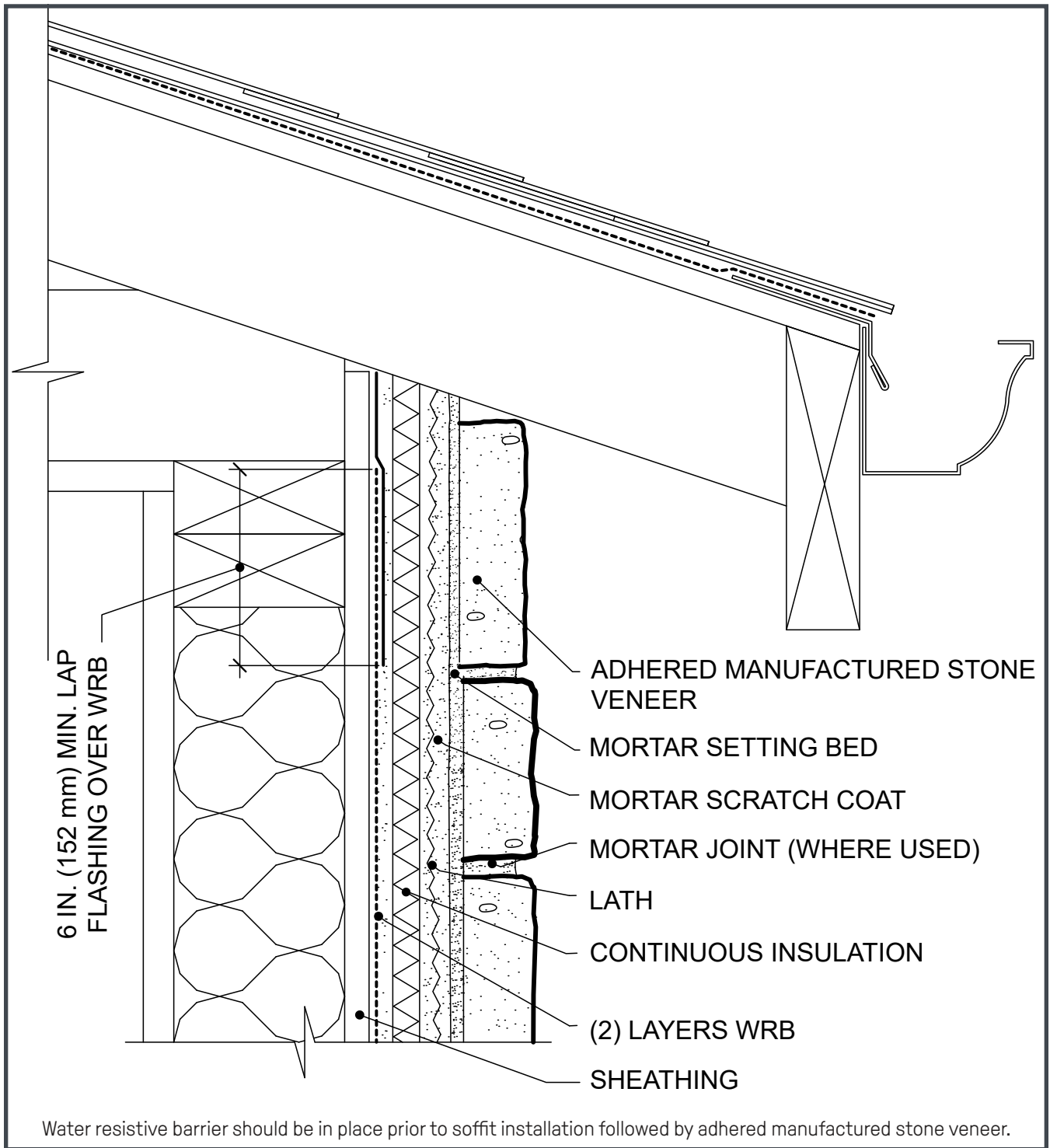
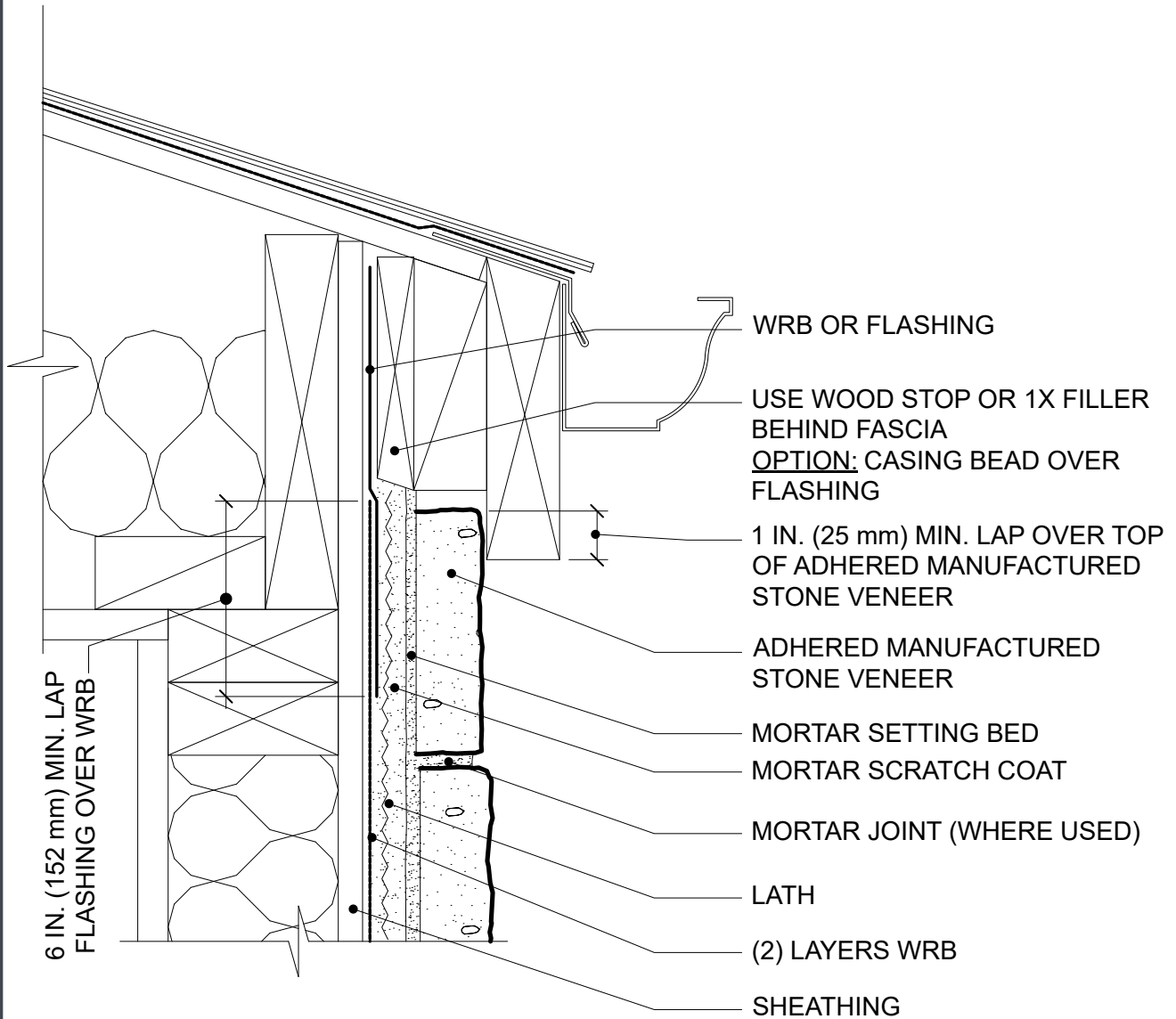


Figure 13b. Open Eave - Overhang Over Continuous Insulation



**Figure 14. Open Eave - Flush**

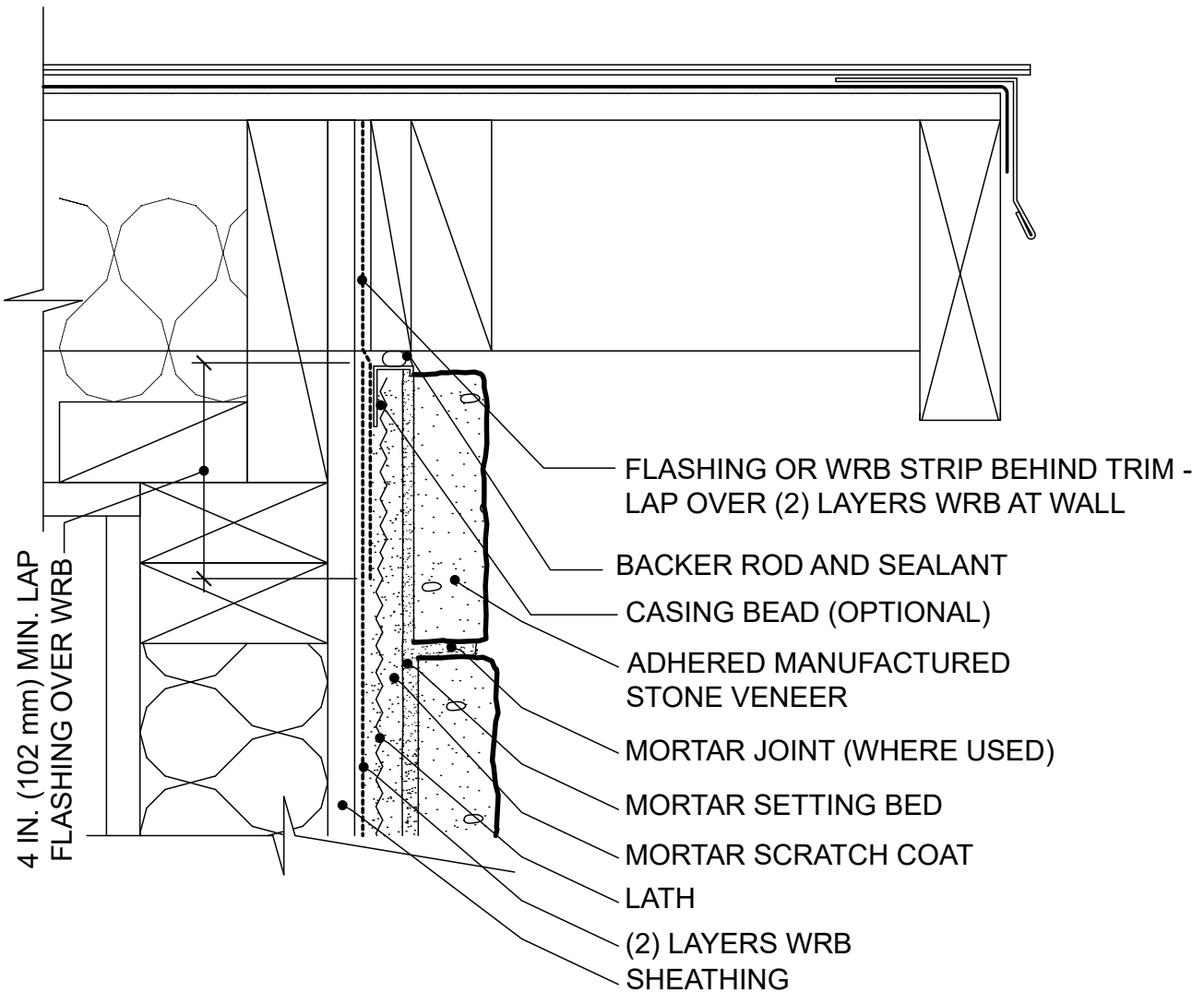
NOTE: FOR CONTINUOUS INSULATION APPLICATIONS, REFER TO FIGURE 13b.



Water resistive barrier should be in place prior to soffit installation followed by adhered manufactured stone veneer.

Figure 15. Rake - Overhang

NOTE: FOR CONTINUOUS INSULATION APPLICATIONS, REFER TO FIGURE 13b.





**Figure 16. Rake - Flush**

NOTE: FOR CONTINUOUS INSULATION APPLICATIONS, REFER TO FIGURE 13b.

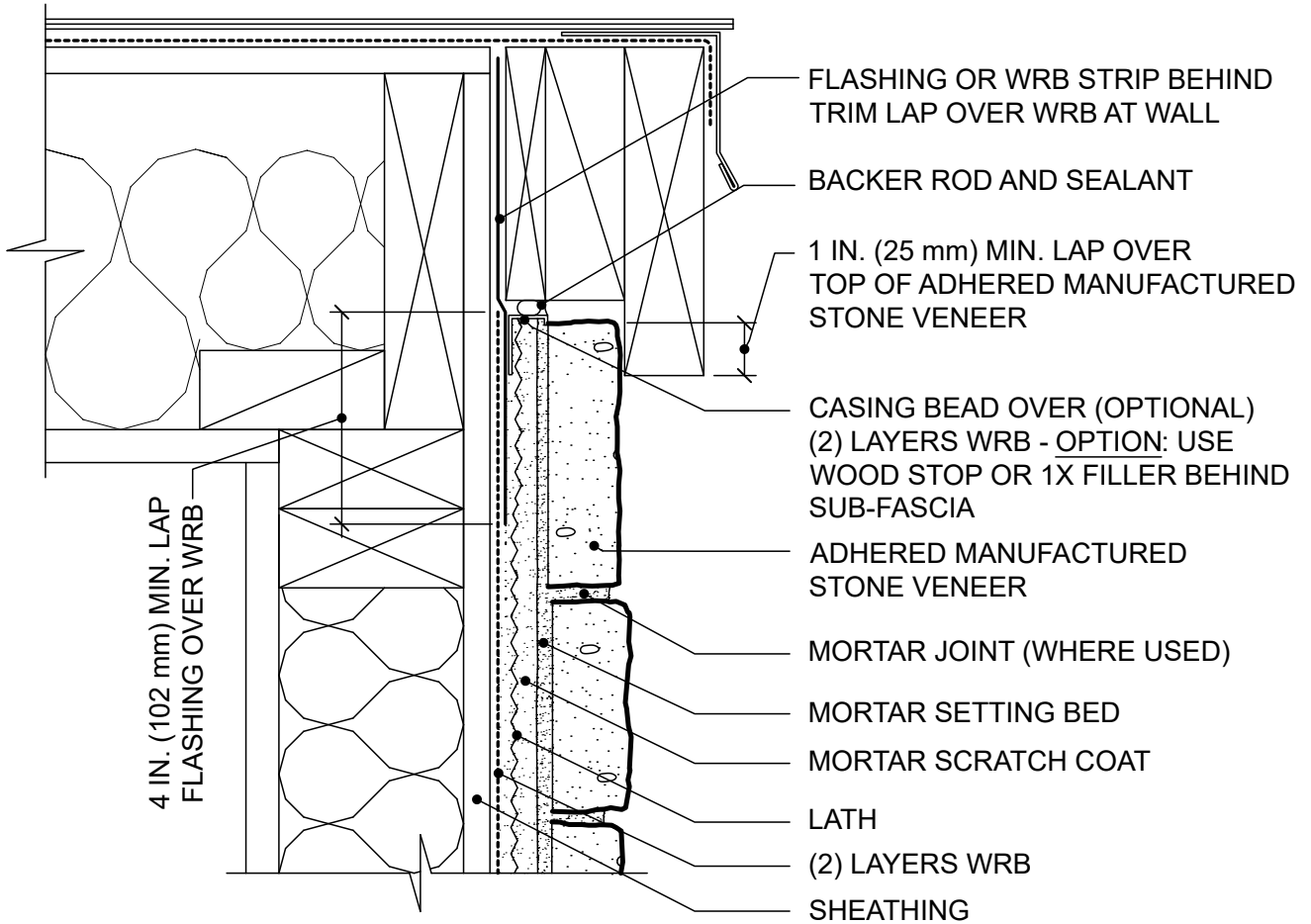
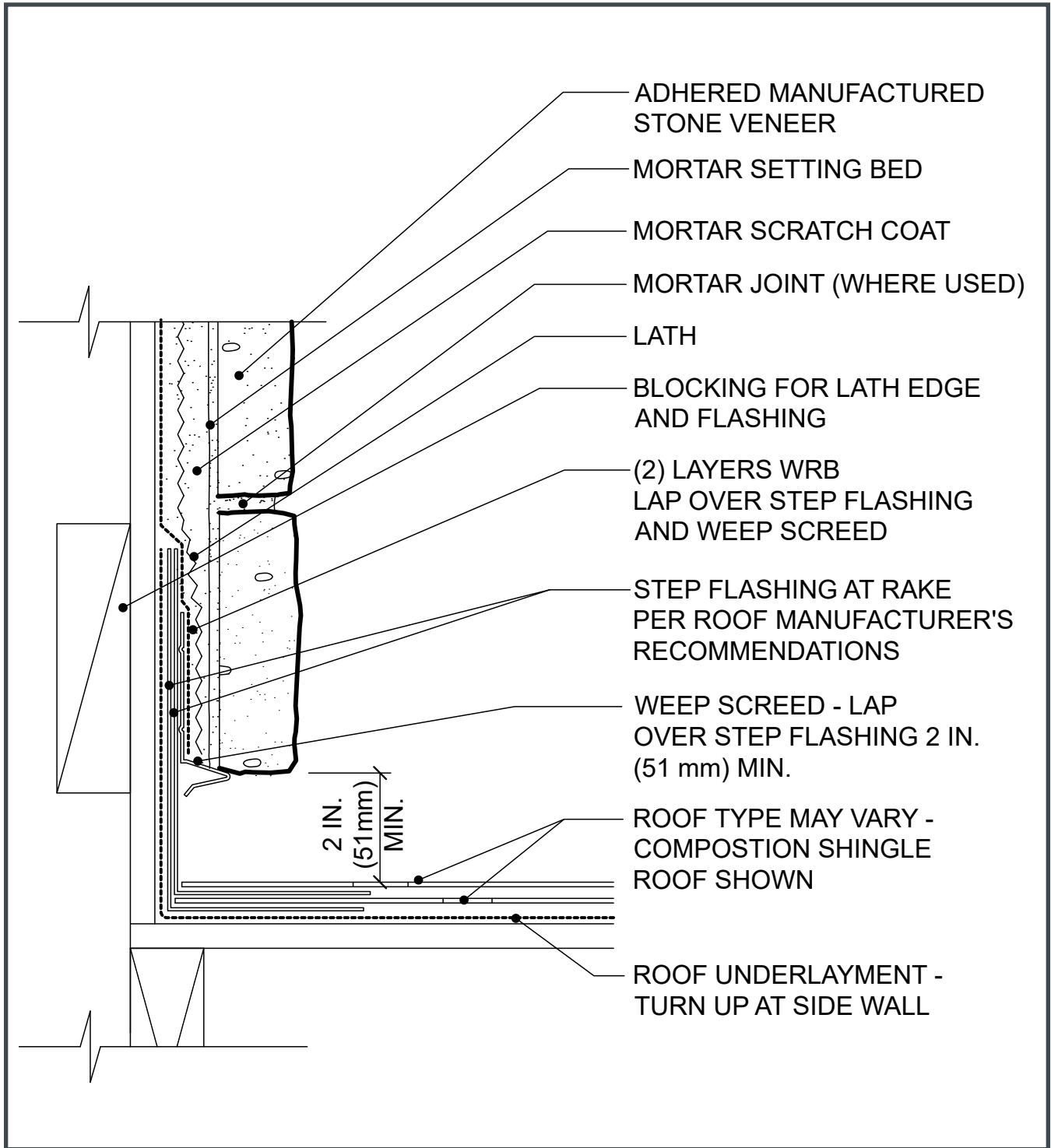
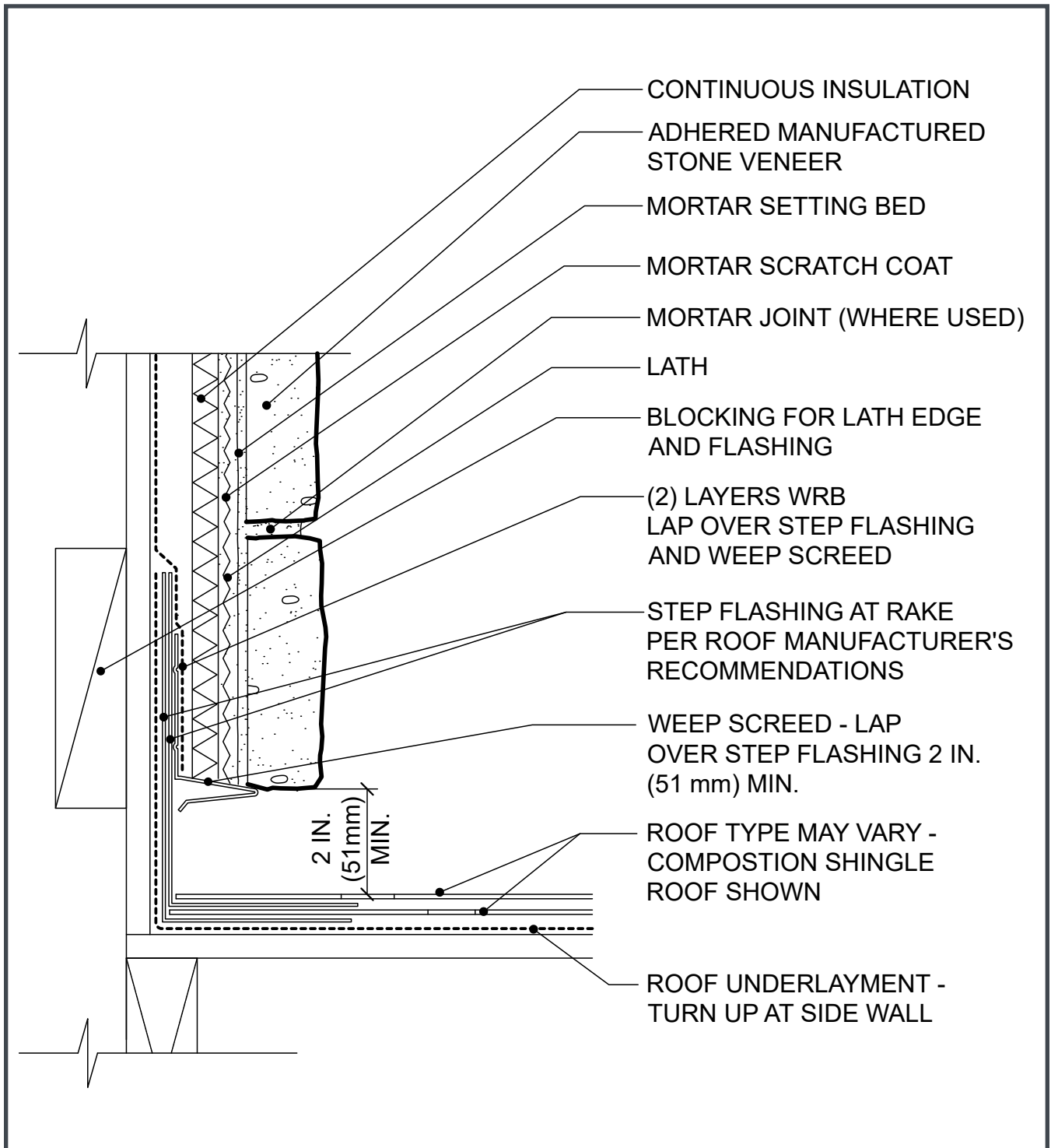


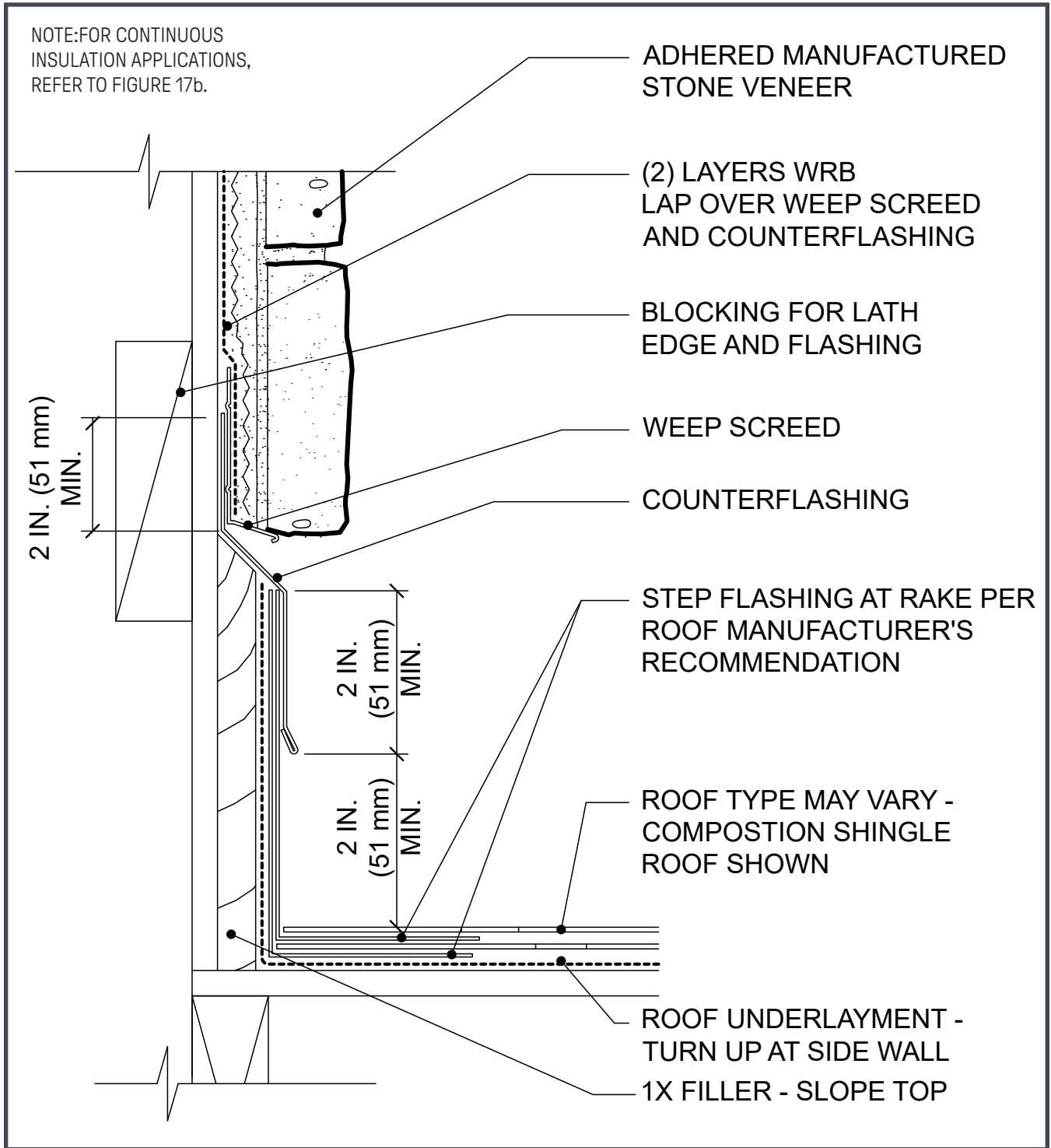
Figure 17a. Side Wall - Composition Shingles



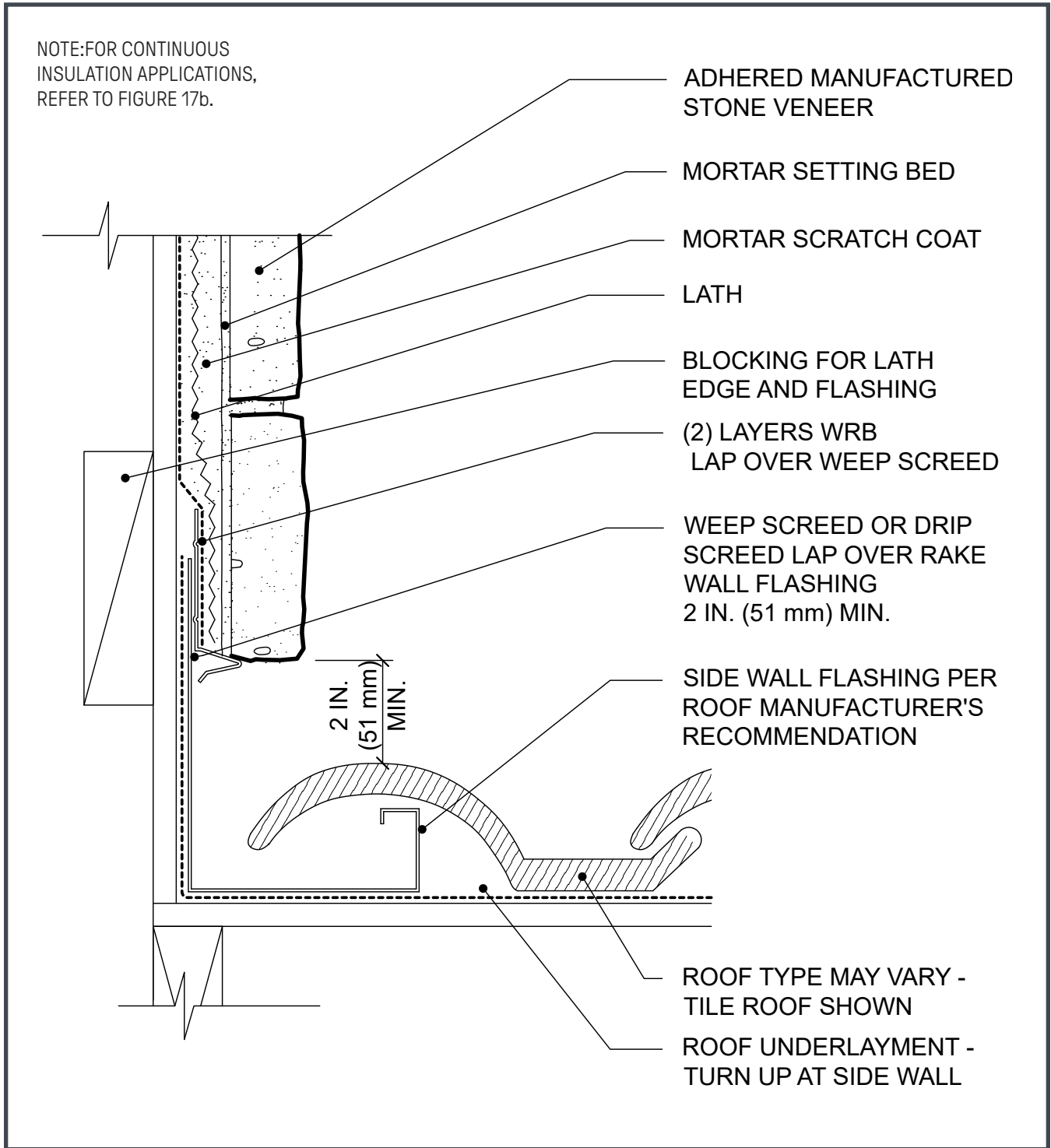
**Figure 17b. Side Wall - Composition Shingles Over Continuous Insulation**



**Figure 18. Side Wall - Composition Shingles Curbing**



**Figure 19. Side Wall - Tile Roofing**



**Figure 20. Side Wall - Tile Roofing Curbing**

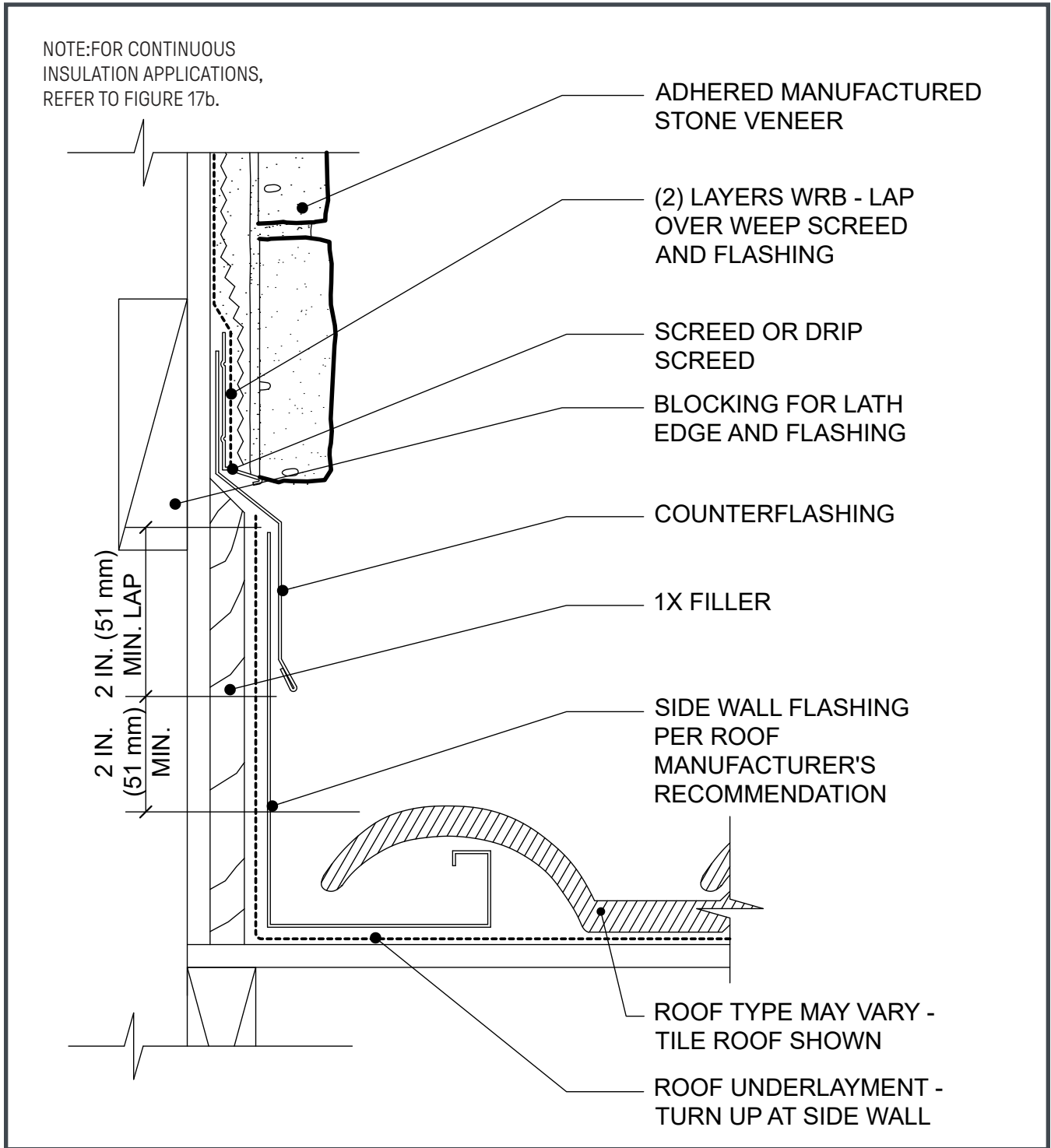
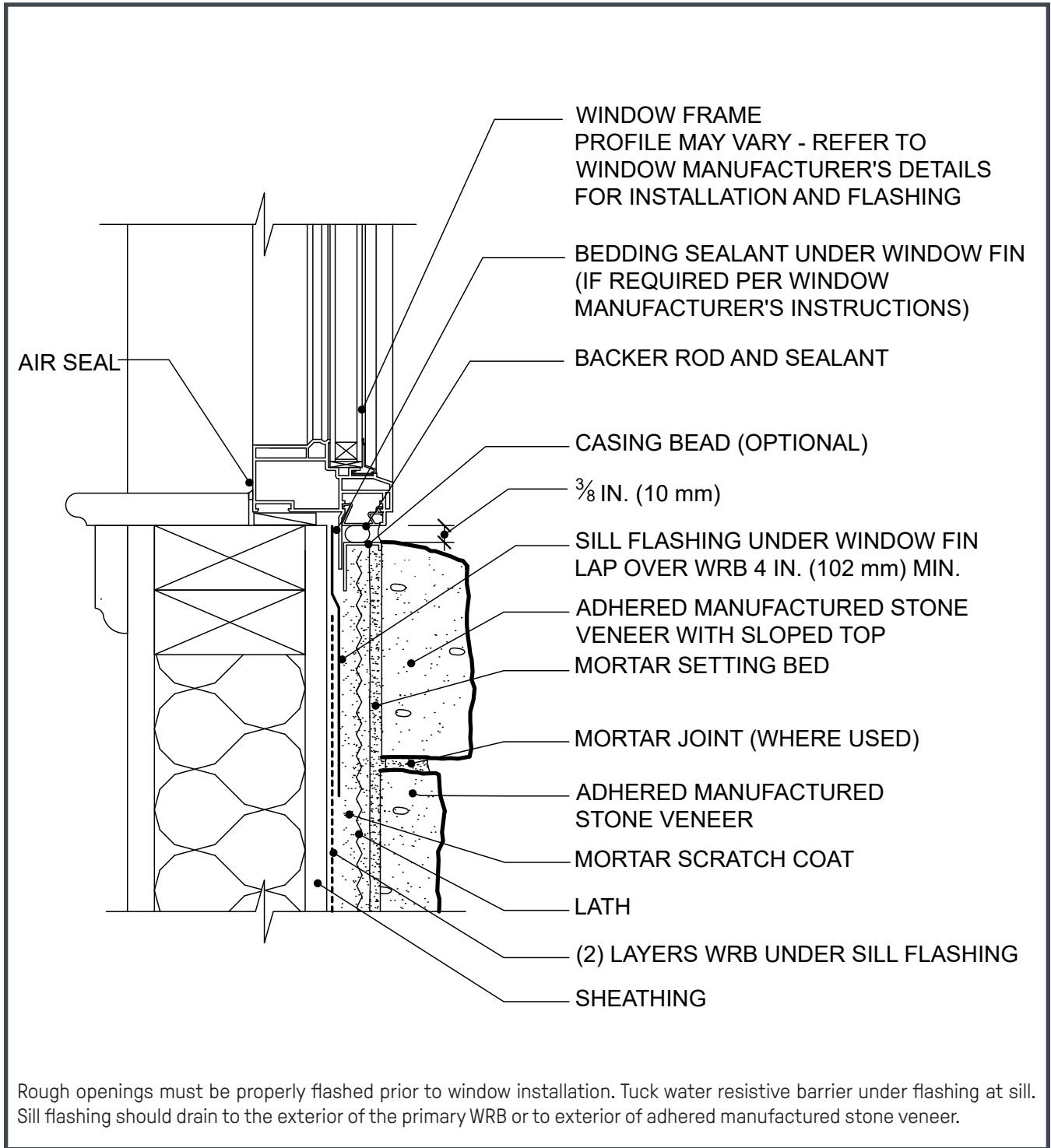
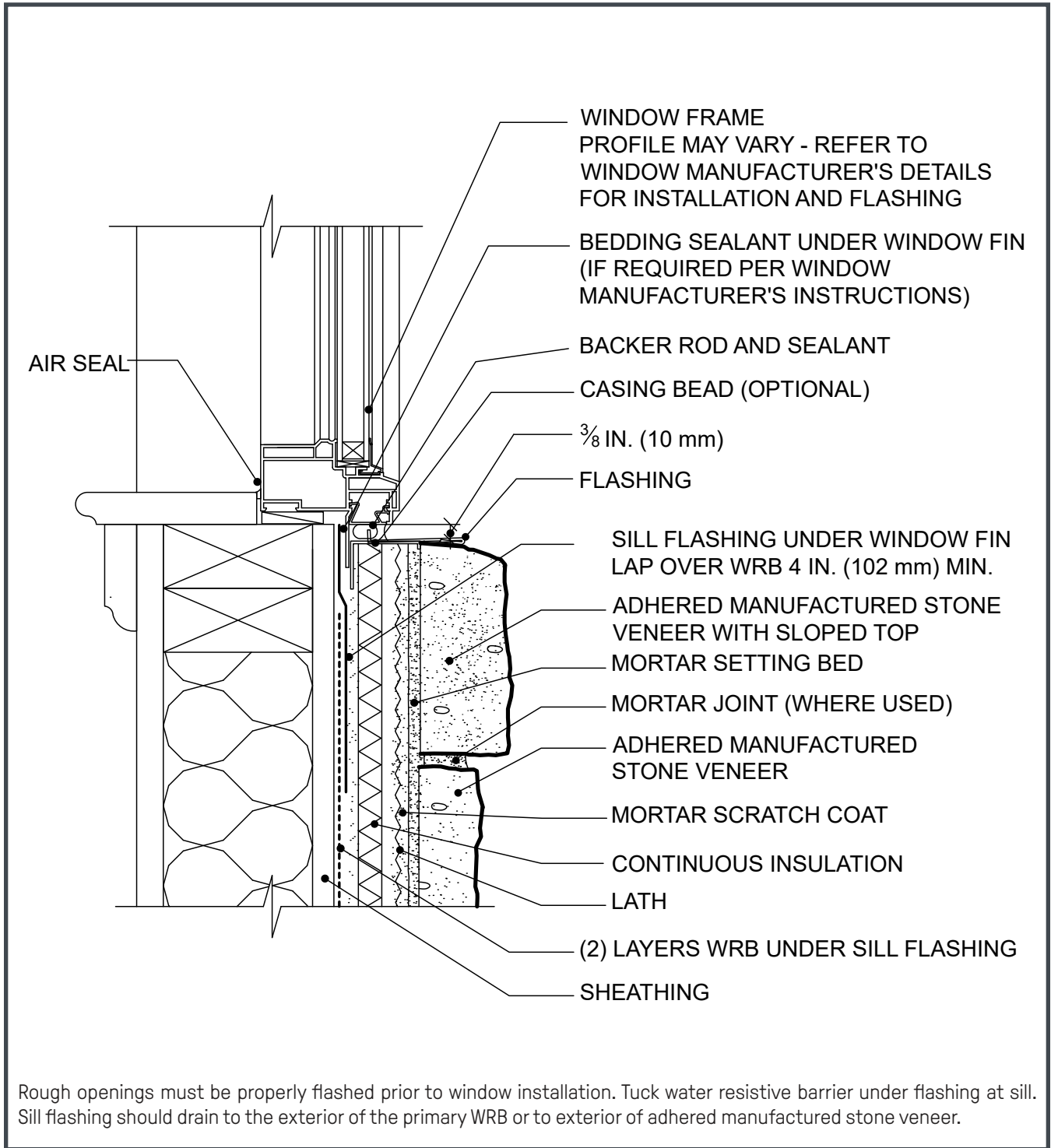


Figure 21a. Window Sill



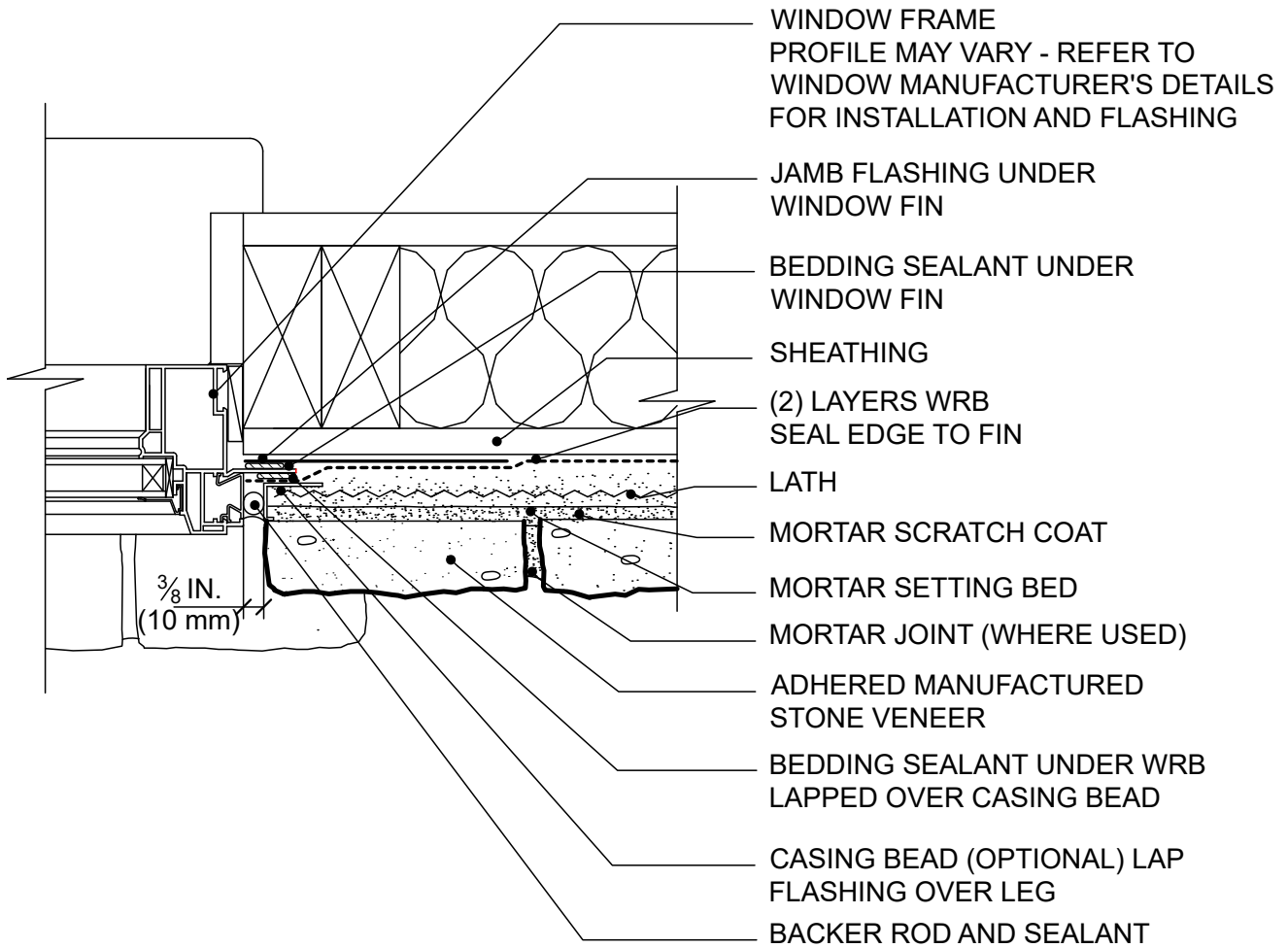
**Figure 21b. Window Sill Over Continuous Insulation**





**Figure 22. Window Jamb**

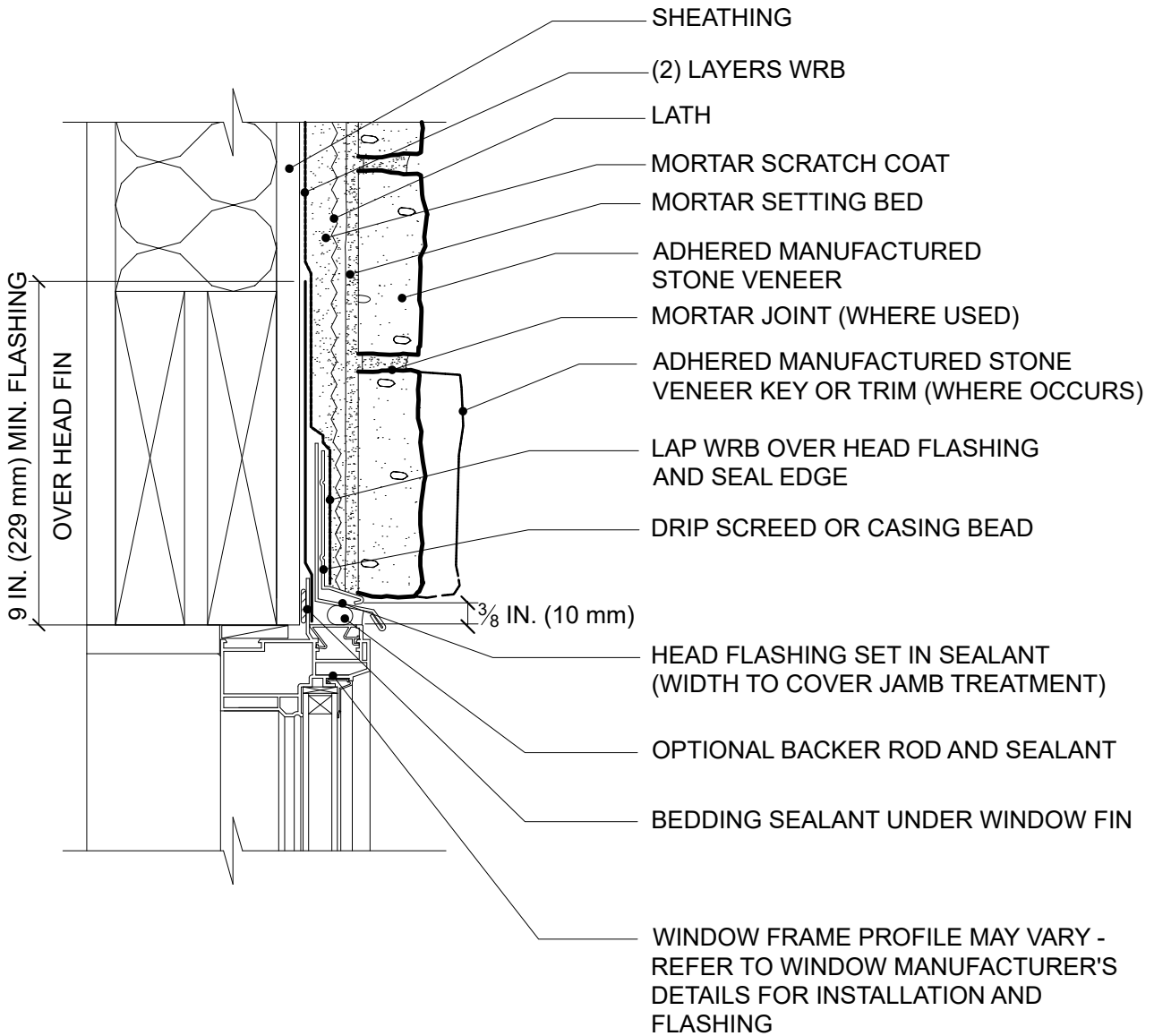
NOTE:FOR CONTINUOUS  
INSULATION APPLICATIONS,  
REFER TO FIGURE 21b.



Rough openings must be properly flashed prior to window installation. Backer rod and sealant between the window frame and the adhered manufactured stone veneer allows for movement between the dissimilar materials.

**Figure 23. Window Head**

NOTE: FOR CONTINUOUS INSULATION APPLICATIONS, REFER TO FIGURE 21b.



Flashing and WRB installed shingle fashion may be complimented with self-adhered flashing (SAF) to seal WRB to window frame.

Figure 24. Kick-Out Flashing

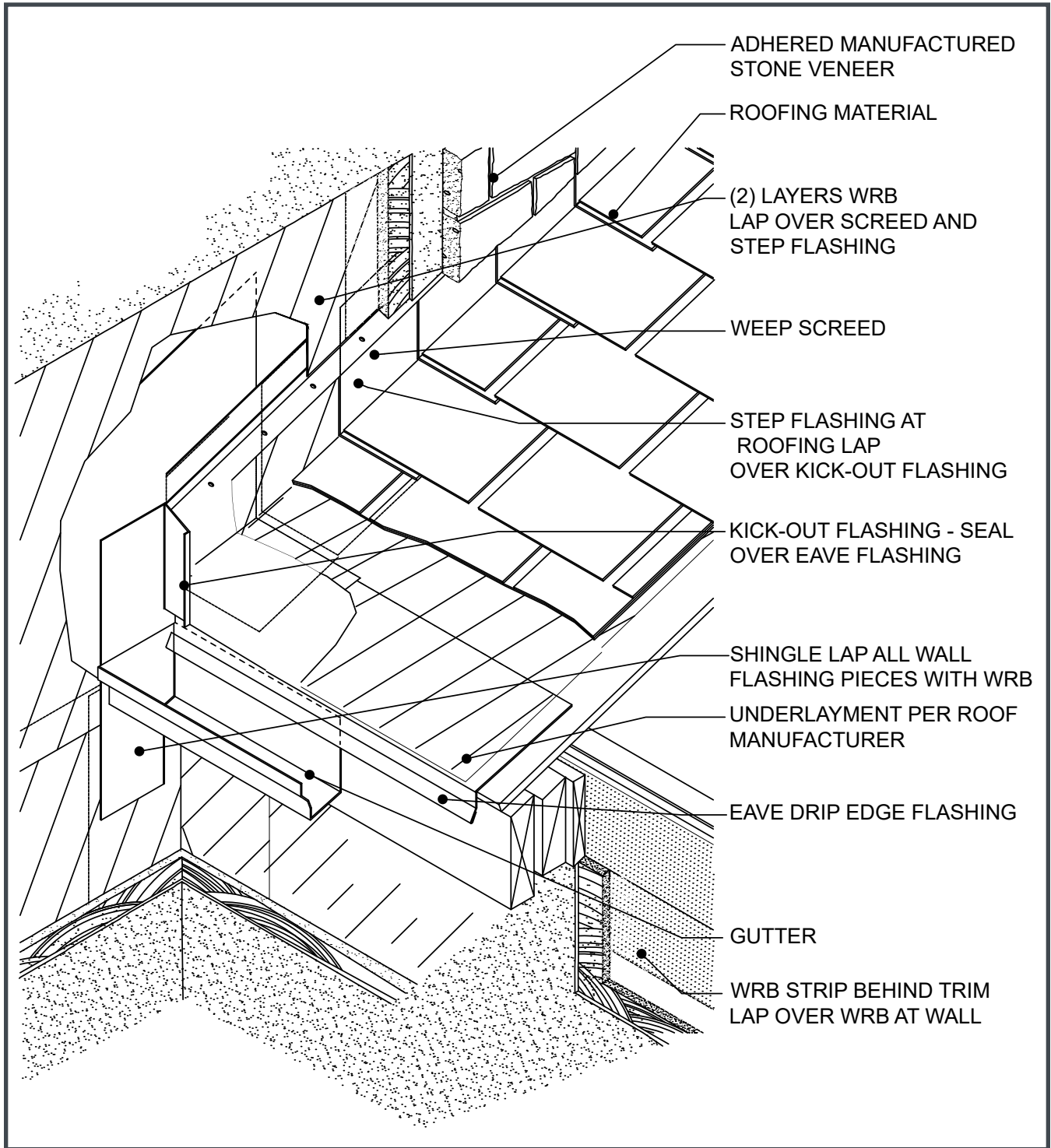
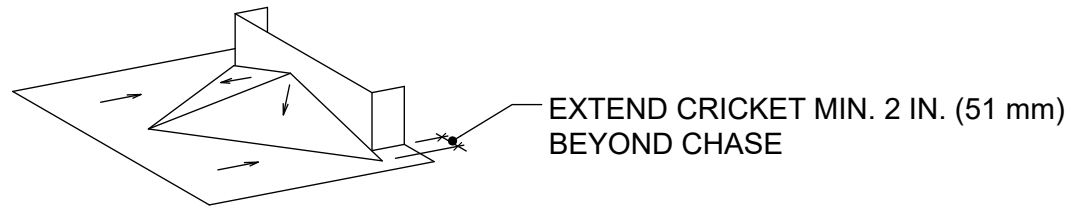
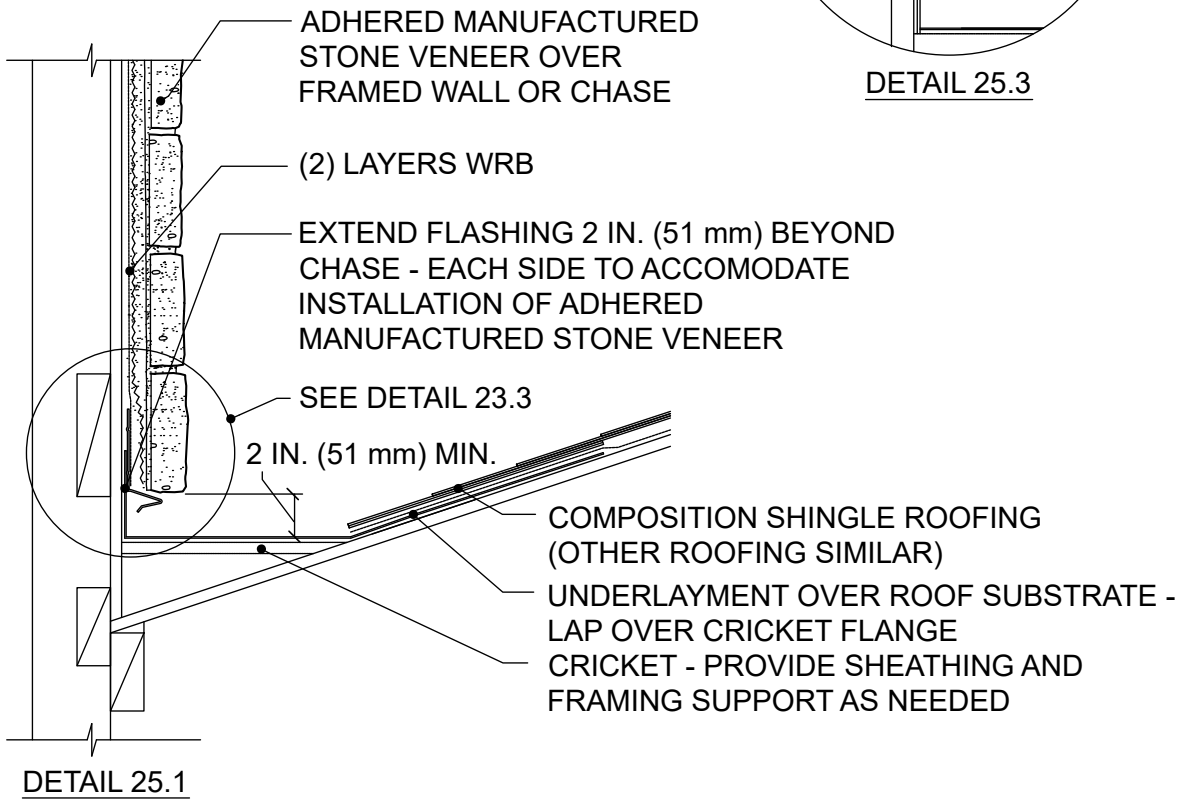
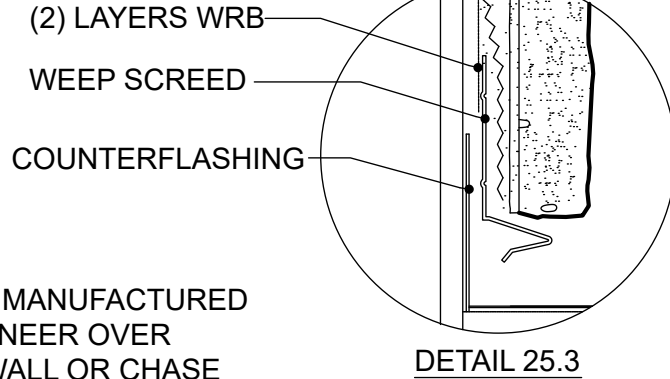


Figure 25. Cricket



TYPICAL CRICKET  
PER ROOF MANUFACTURER'S  
RECOMMENDATIONS  
DETAIL 25.2



**Figure 26. Chimney Chase**

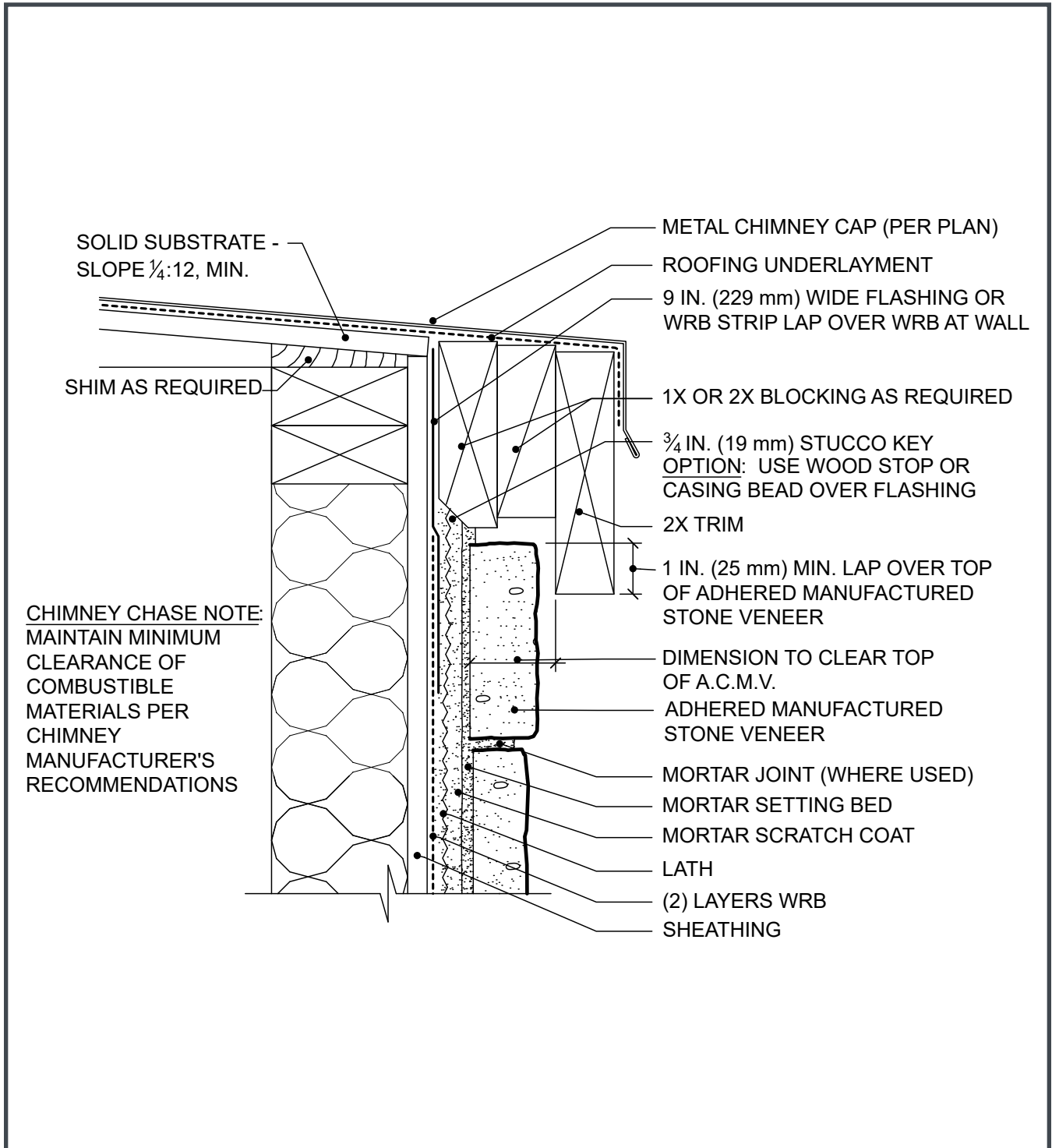
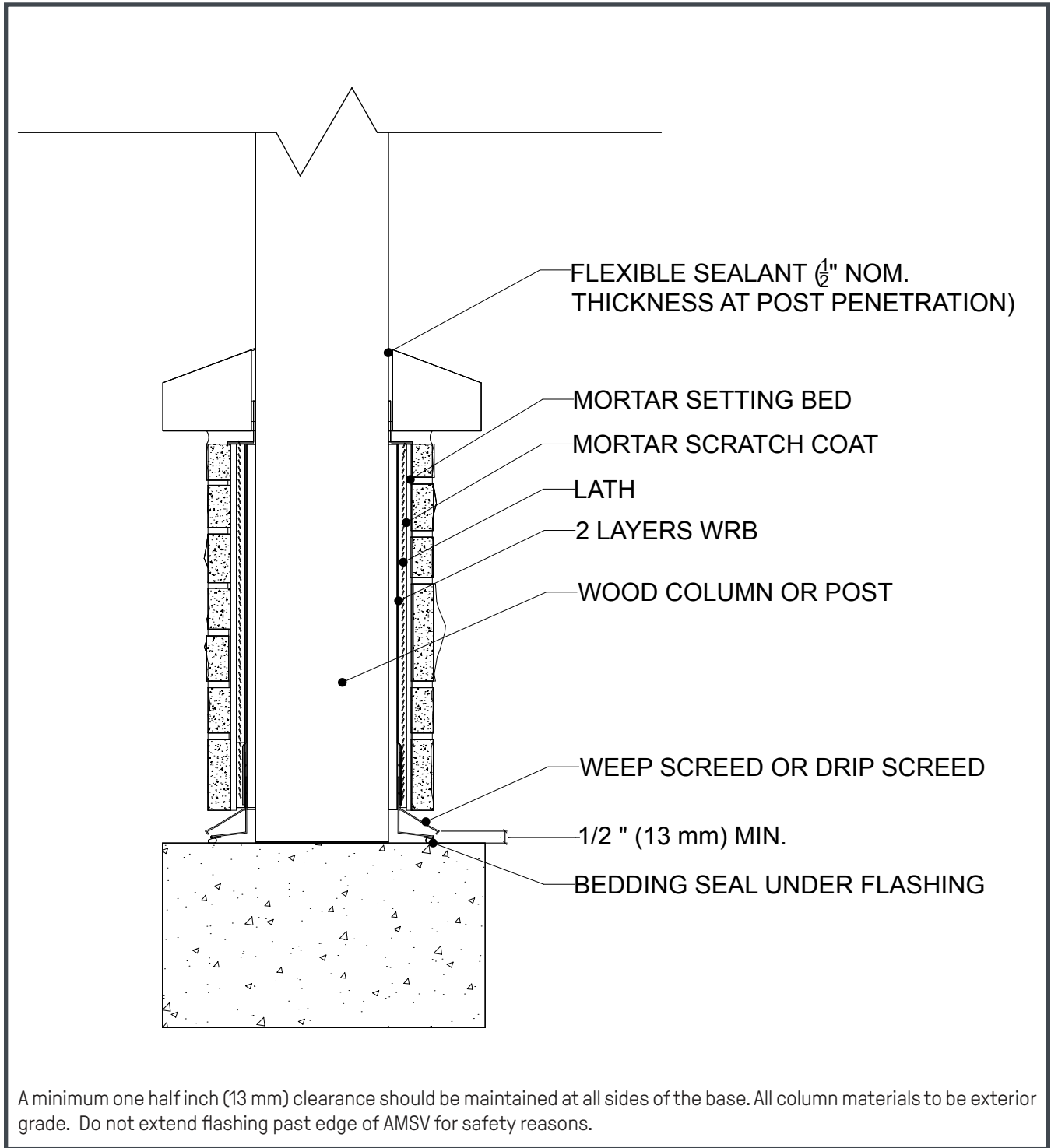
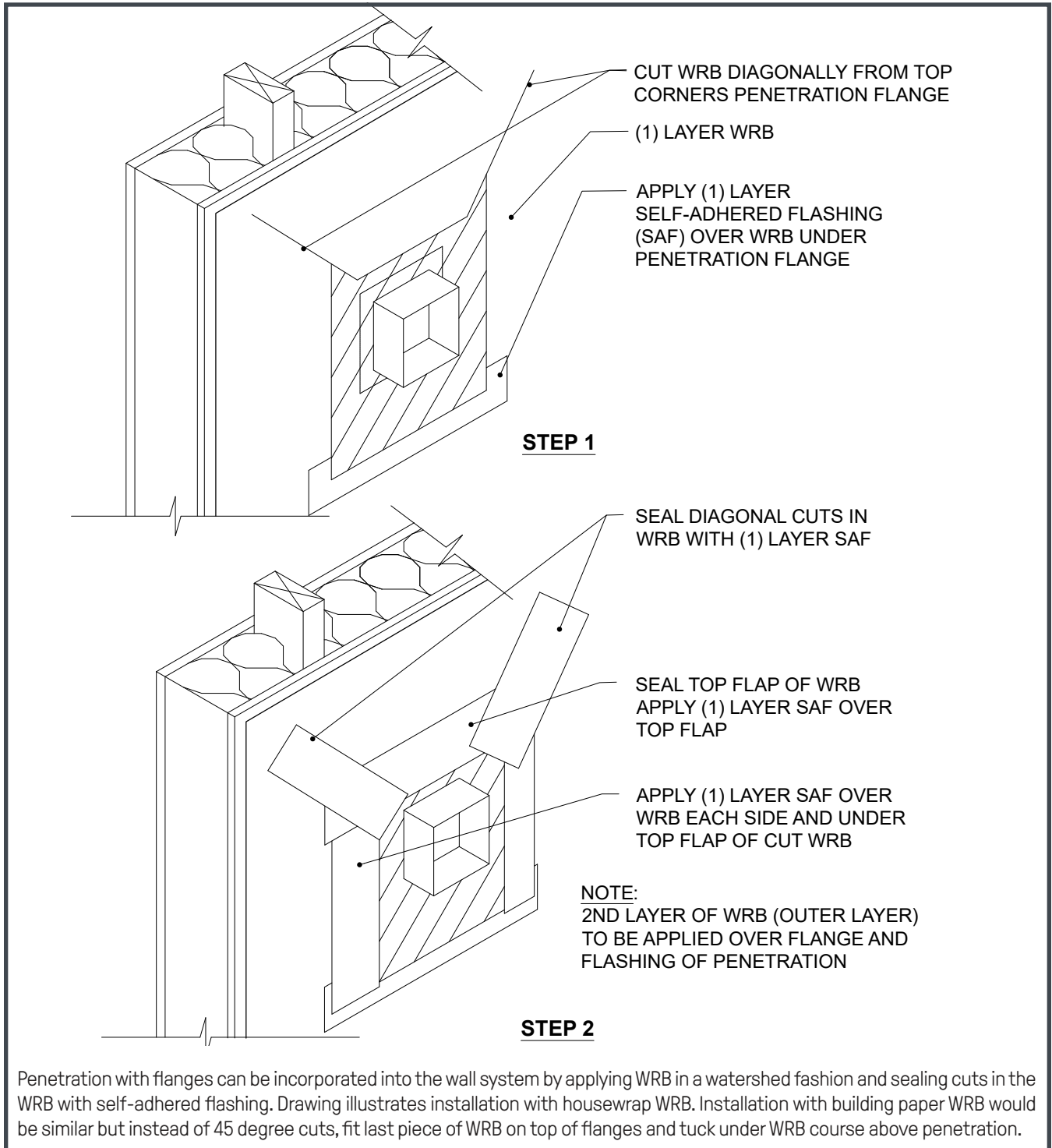


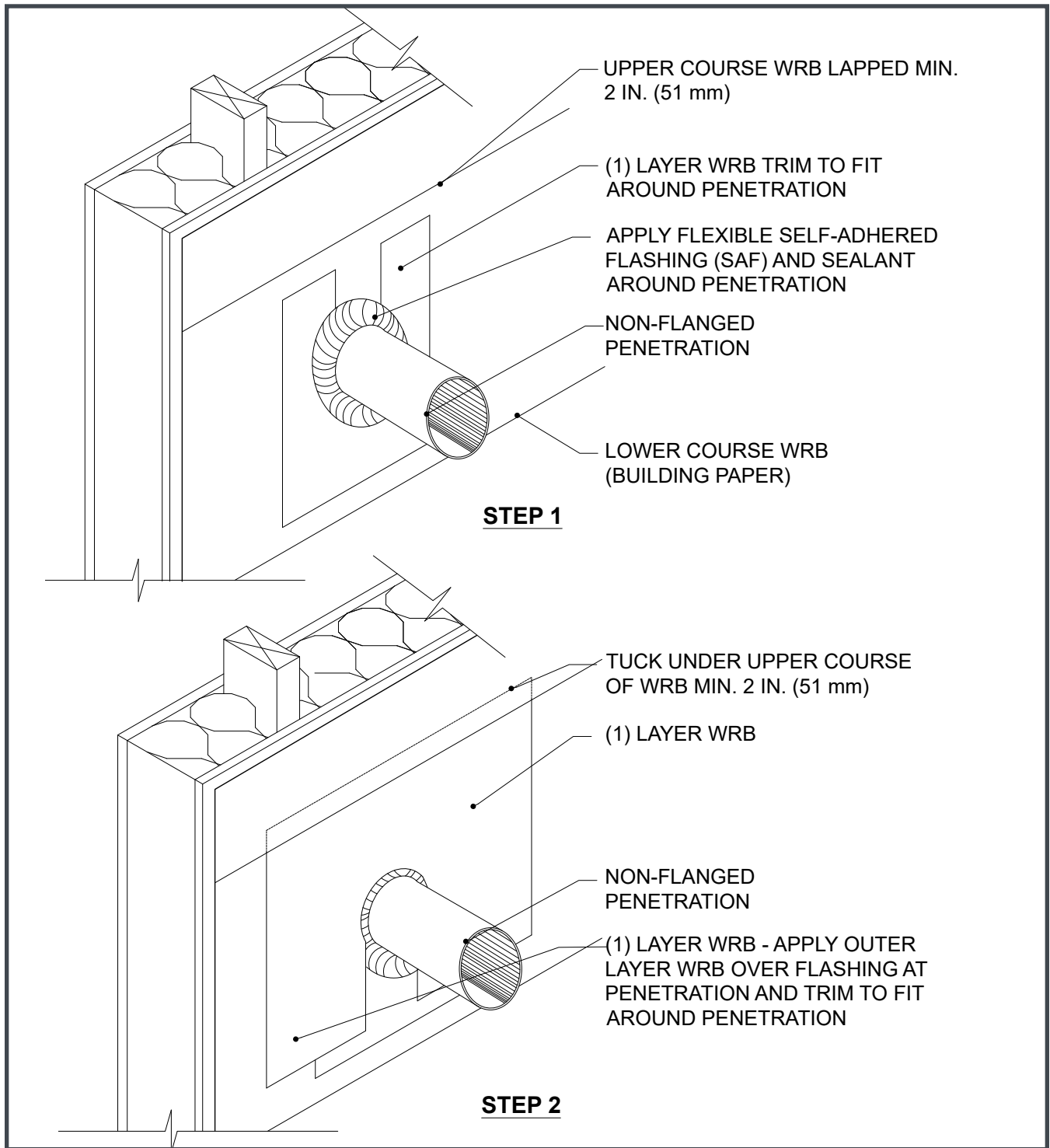
Figure 27. Wood Column with Penetration Through Cap



**Figure 28. Penetration, Flanged**



**Figure 29. Penetration Non-Flanged, with Building Paper WRB**





**Figure 30. Penetration Non-Flanged, with Housewrap WRB**

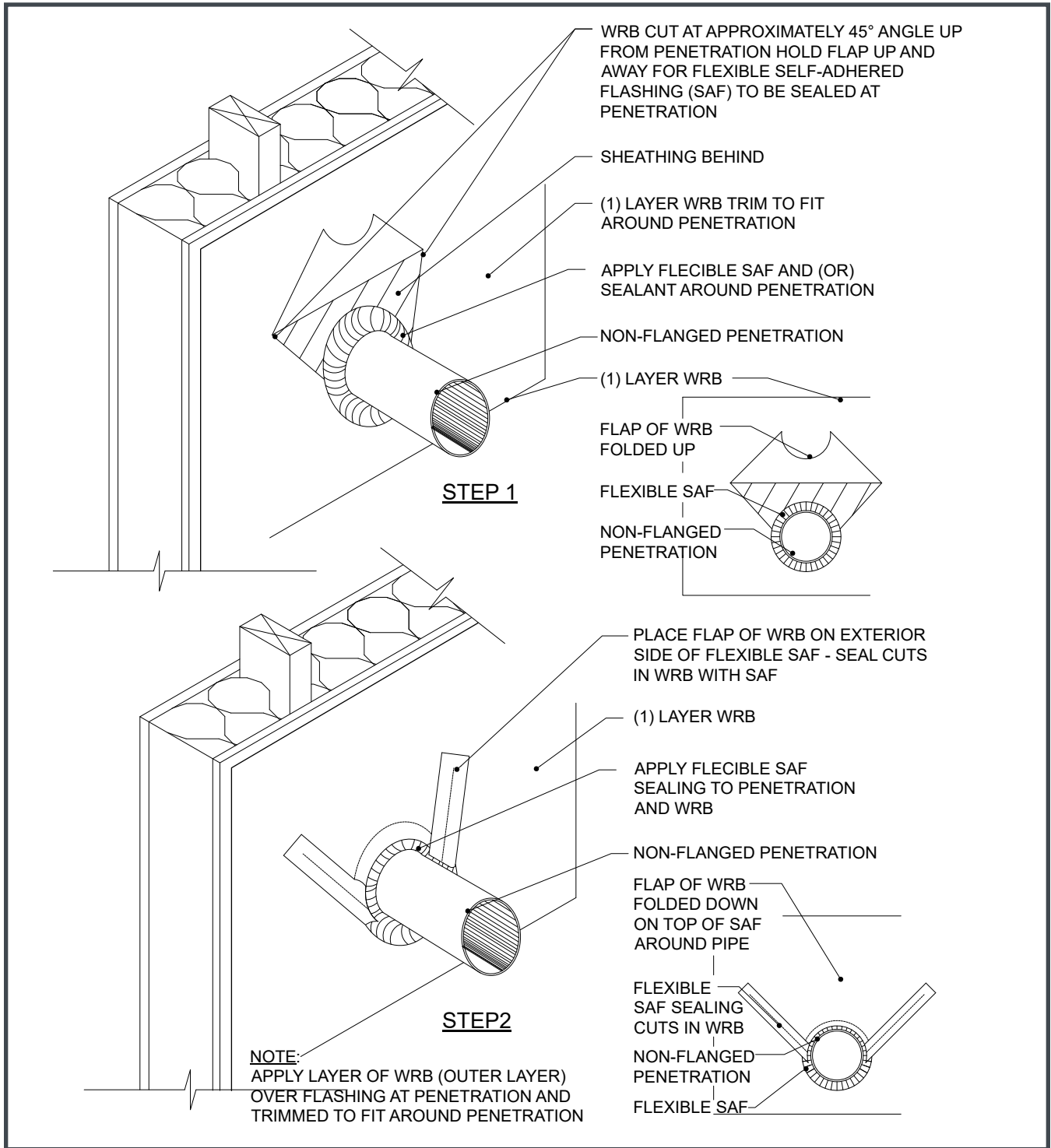
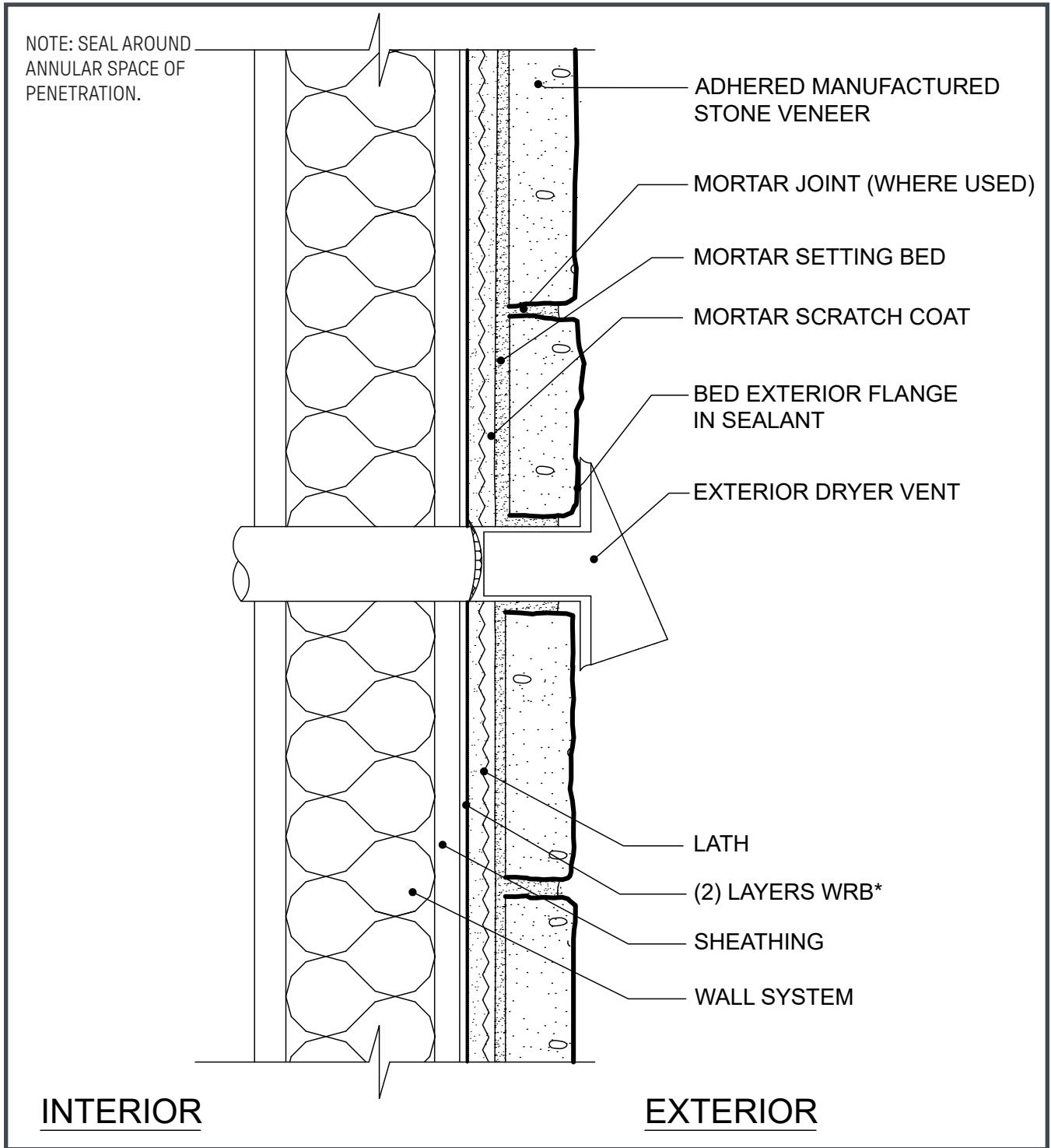




Figure 32. Penetration, Dryer Vent



**Figure 33. Deck Termination**

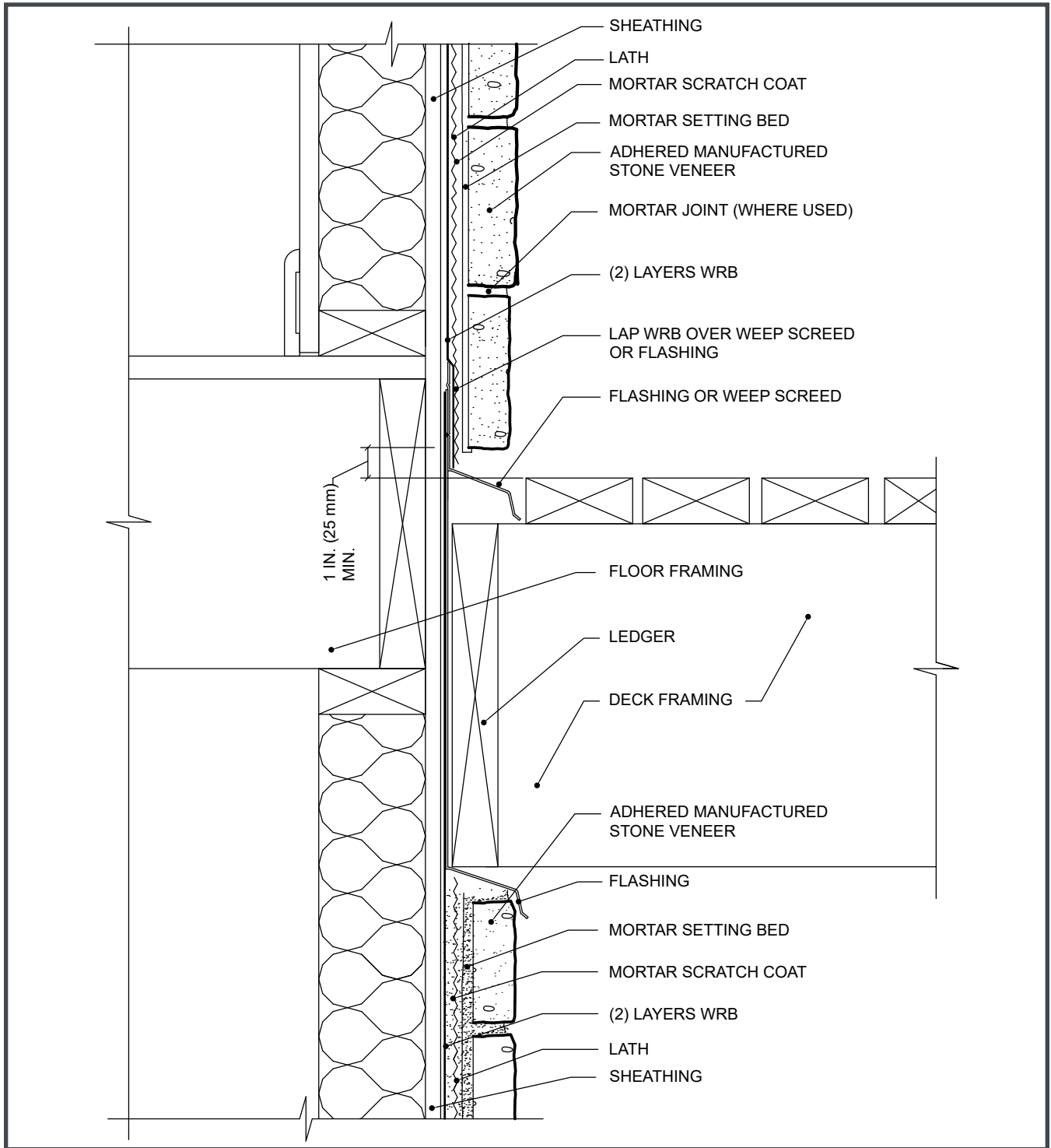
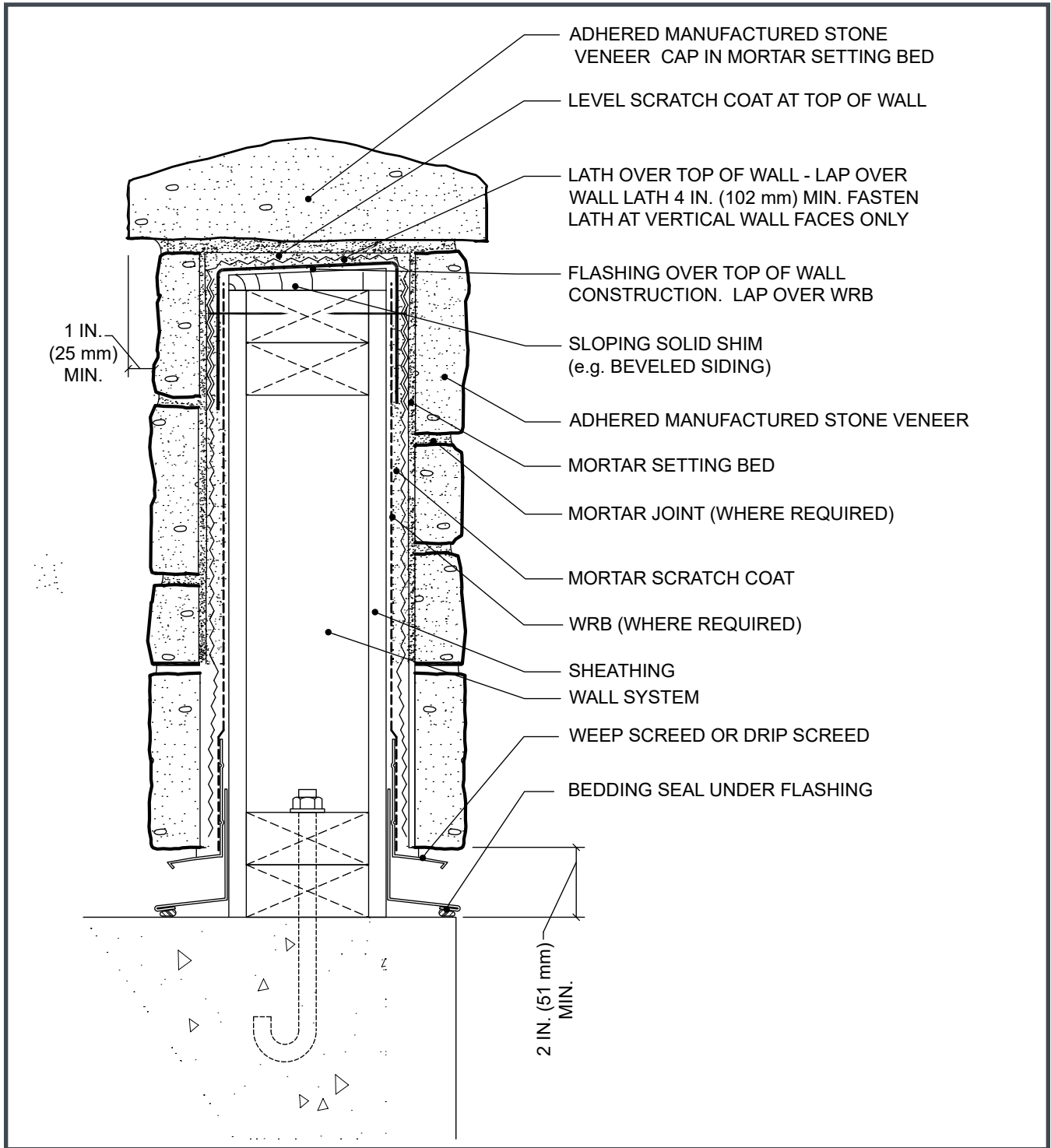
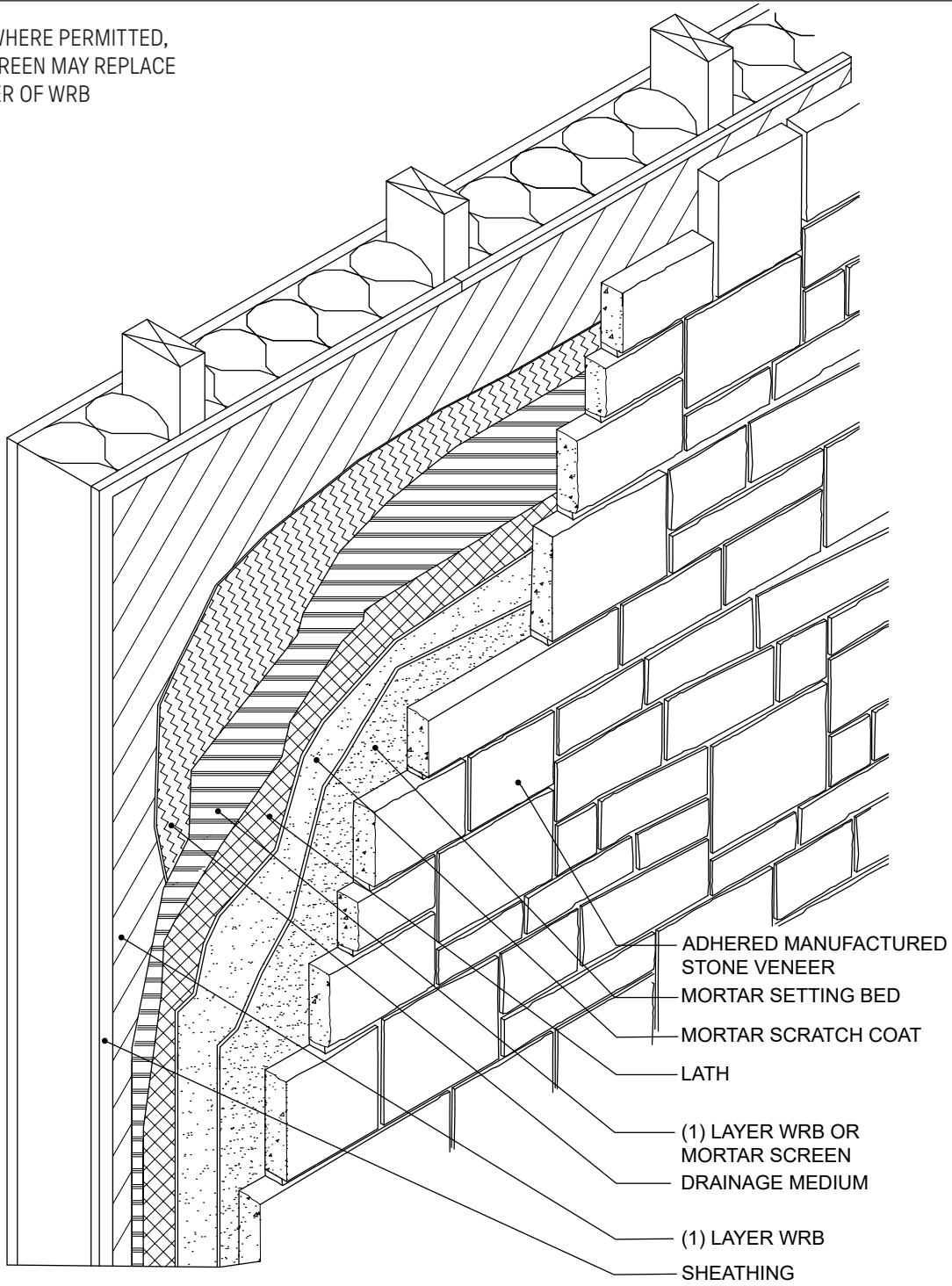


Figure 34. Wall Cap



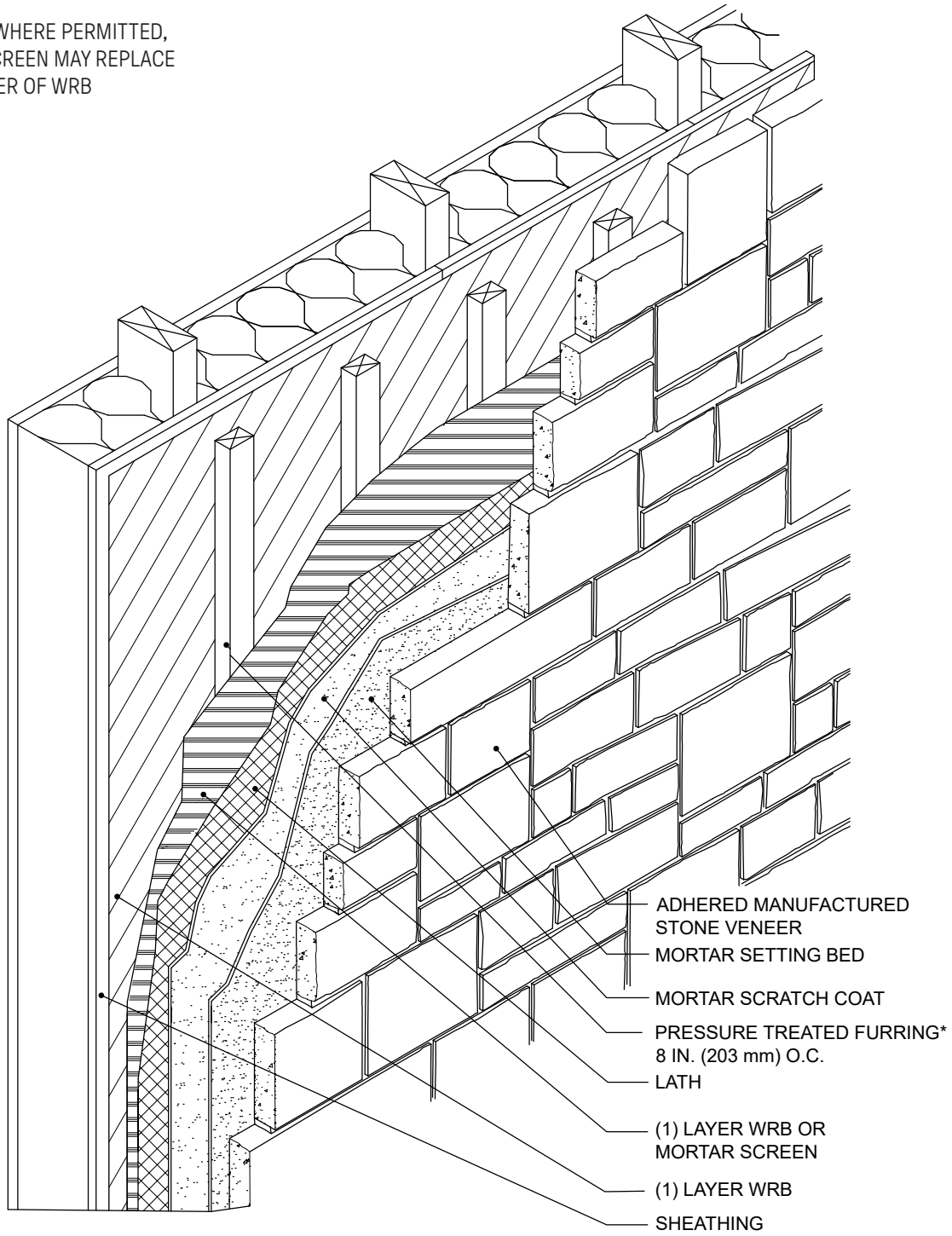
**Figure 35. Wall Assembly - Rainscreen System - Membrane System**

NOTE: WHERE PERMITTED,  
RAINSCREEN MAY REPLACE  
(1) LAYER OF WRB



**Figure 36. Wall Assembly - Rainscreen System - Strapped**

NOTE: WHERE PERMITTED,  
RAINSCREEN MAY REPLACE  
(1) LAYER OF WRB



**Figure 37. Foundation Wall Base - Rainscreen System**

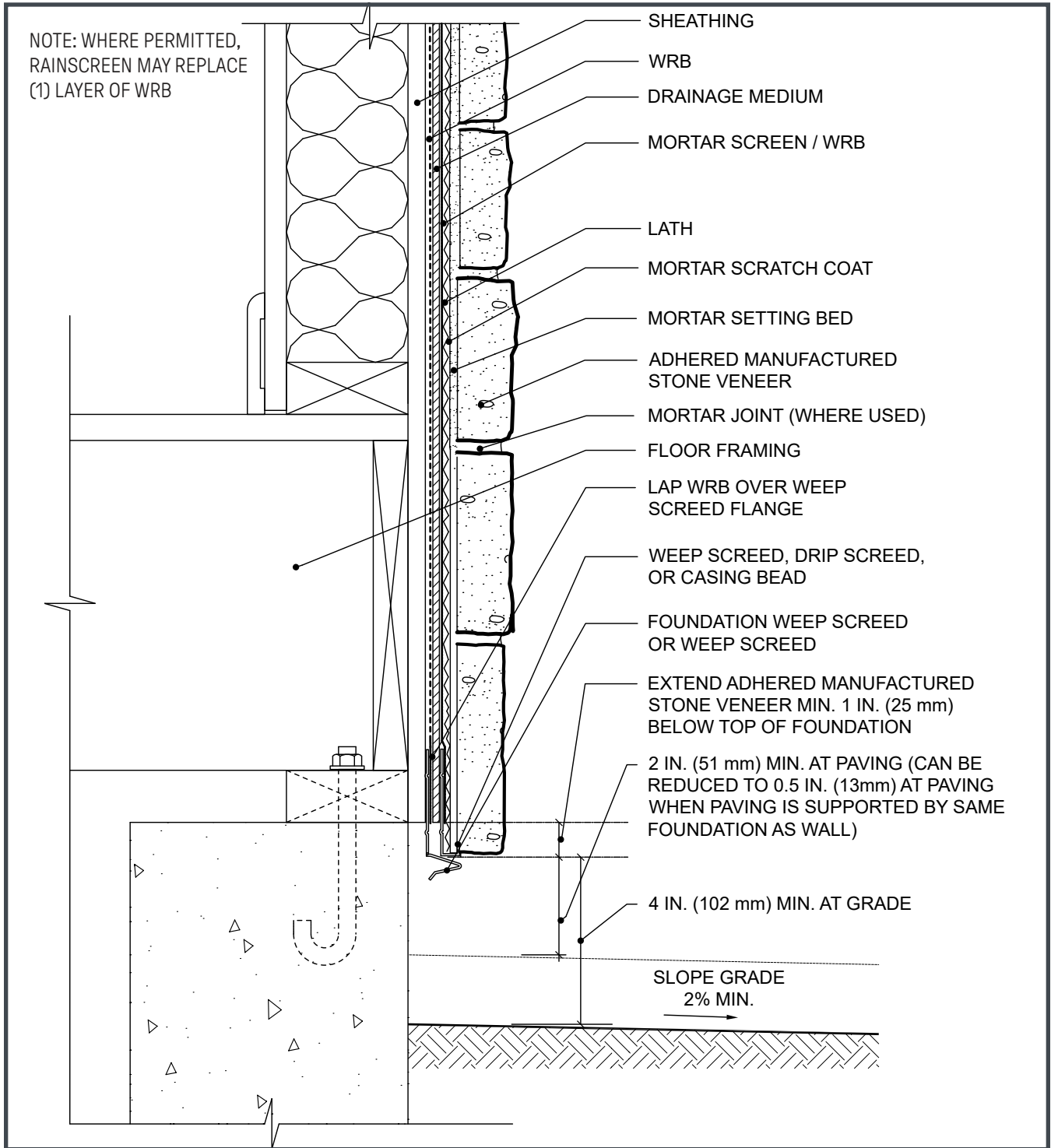
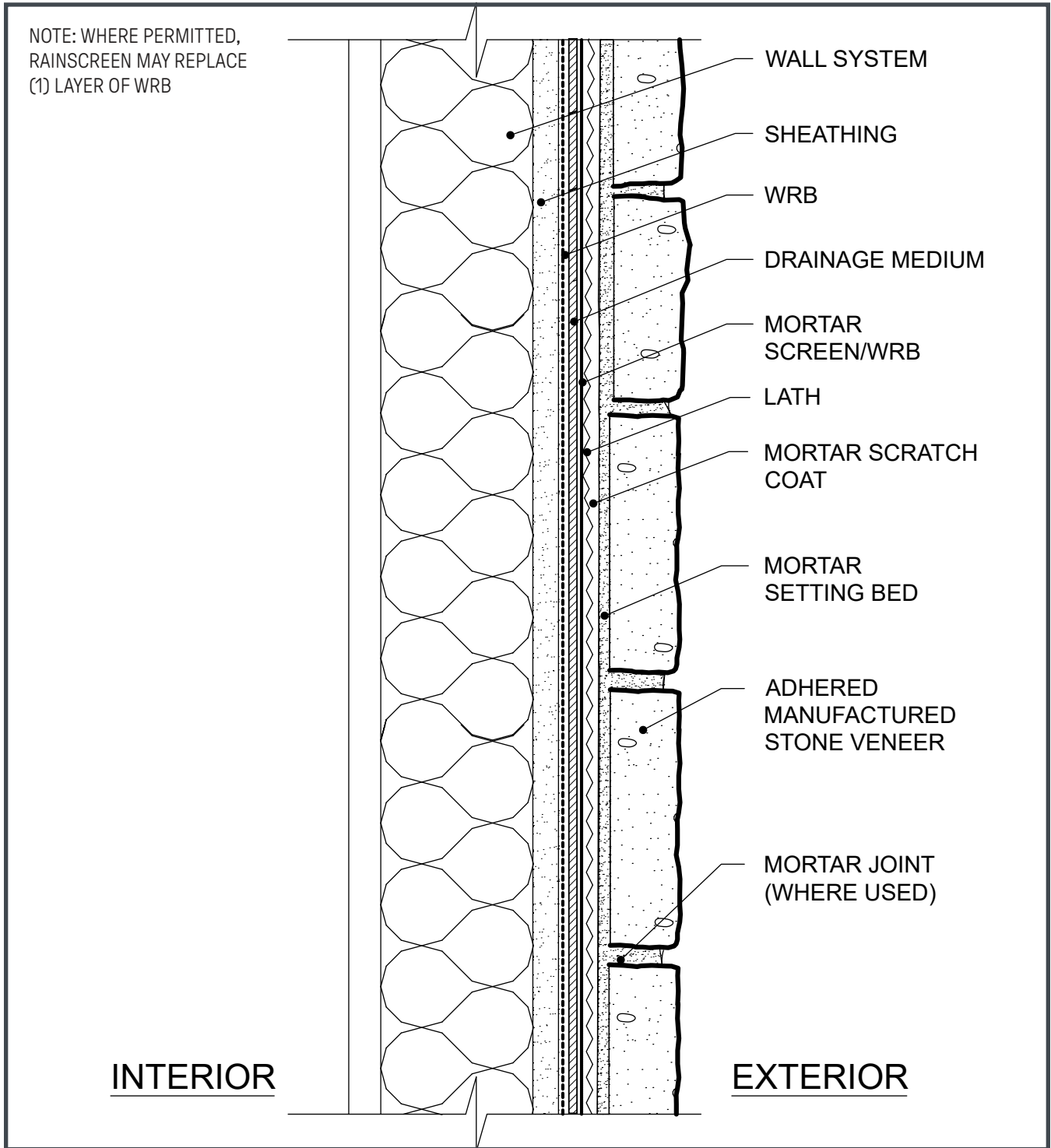
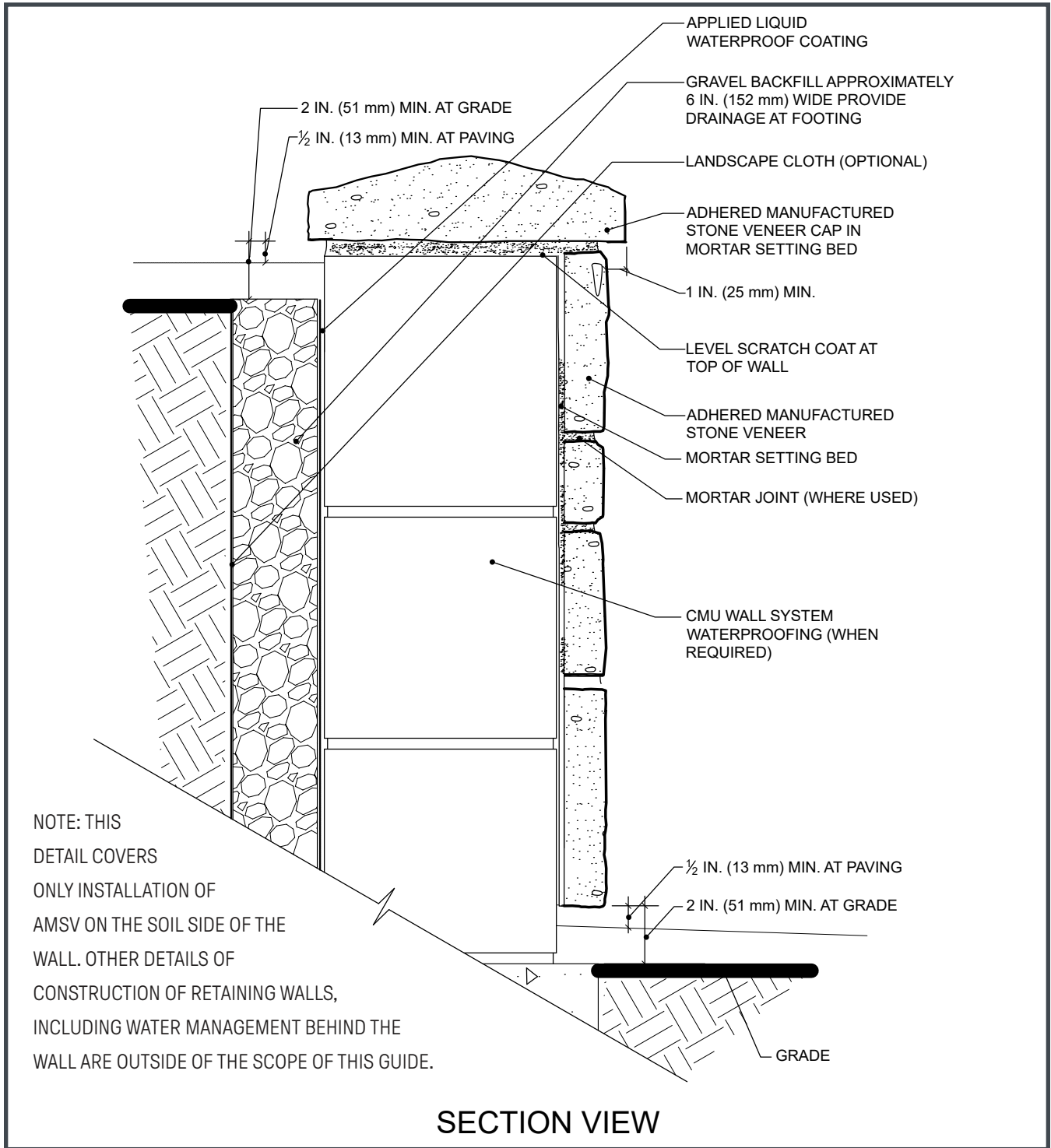




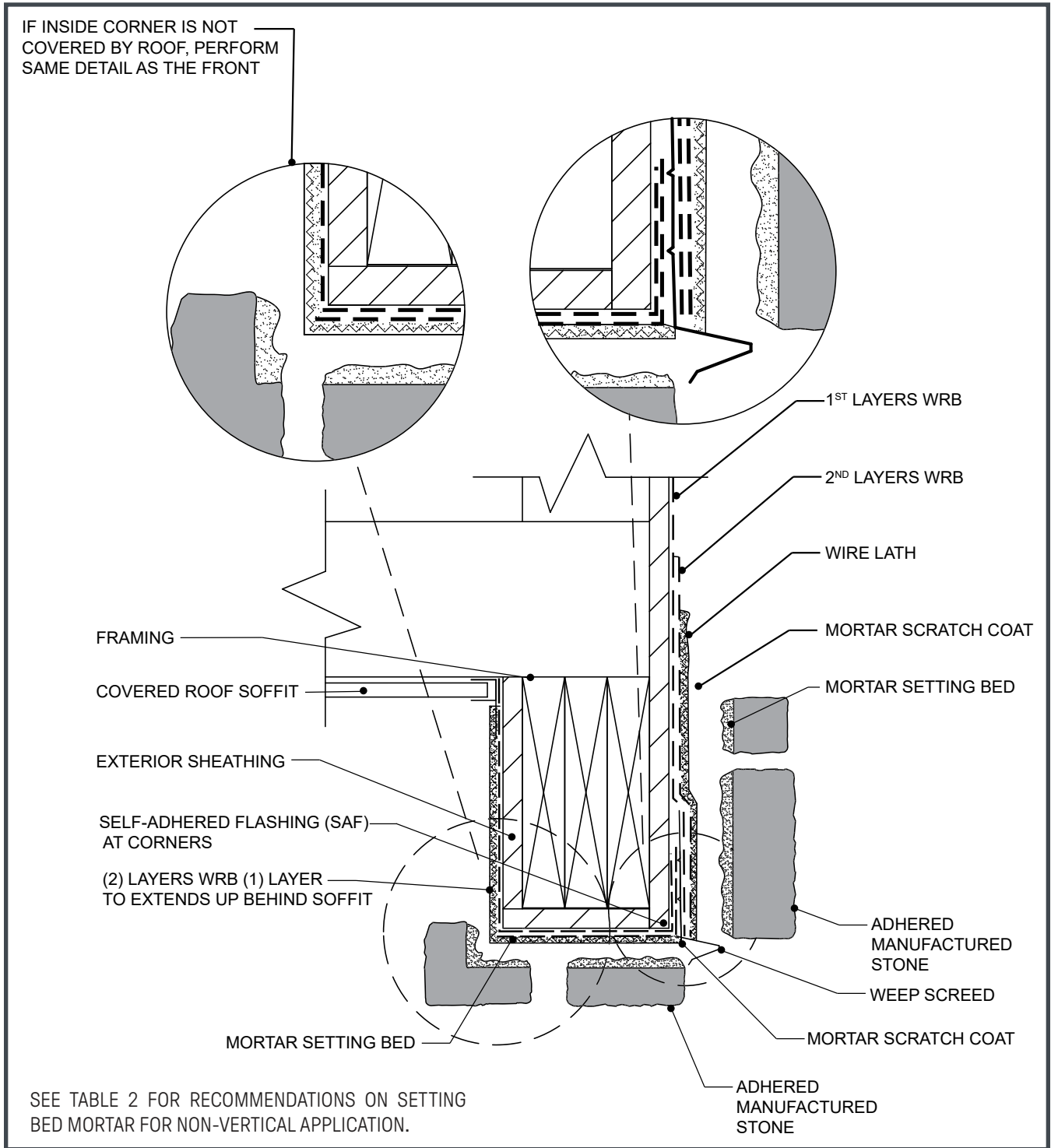
Figure 38. Typical Wall Section - Rainscreen System



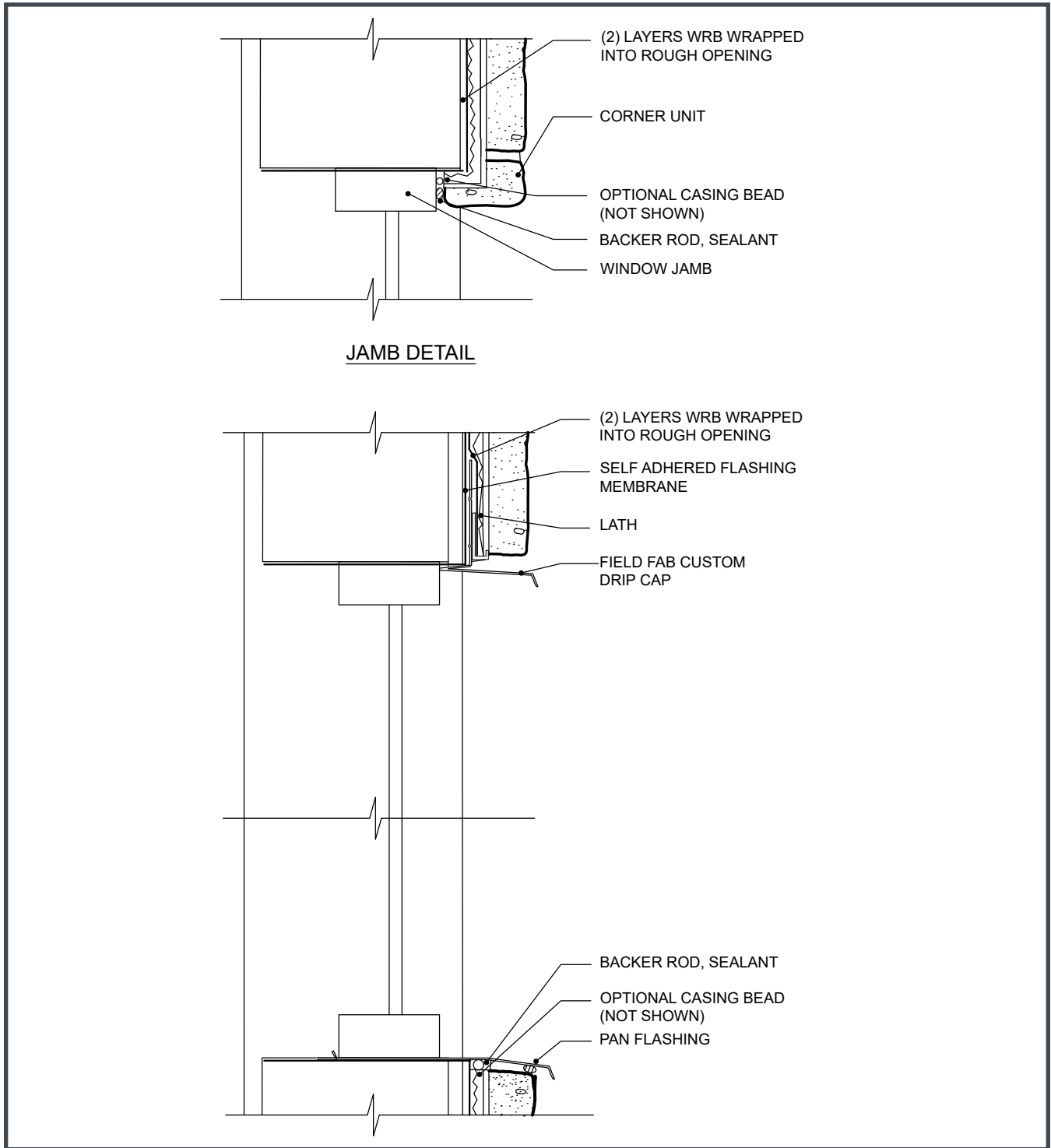
**Figure 39. Retaining Wall (CMU)**



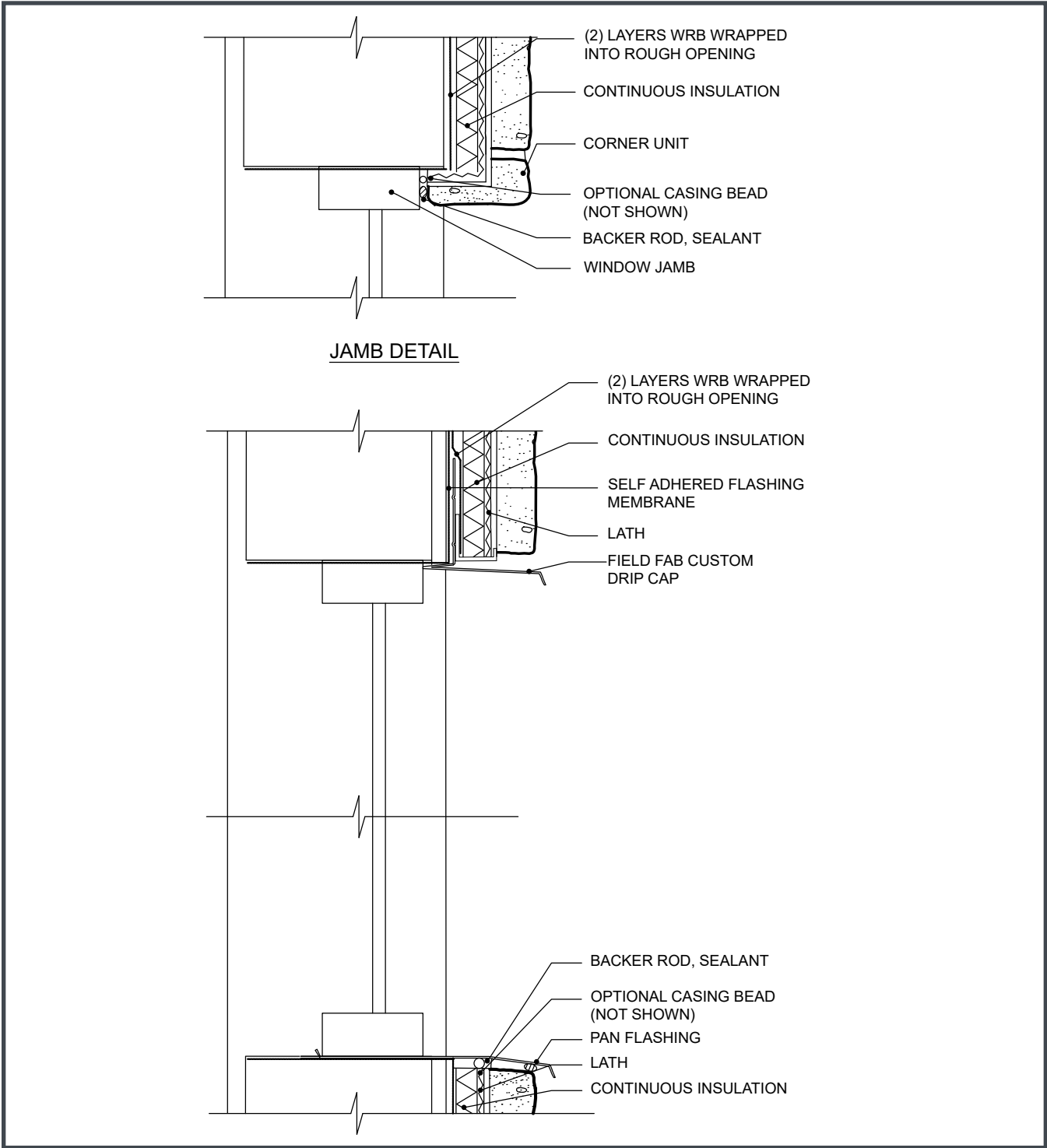
**Figure 40. Stone Wrap Under Straight Overhang**



**Figure 41a. Forward Mounted Commercial Window**



**Figure 41b. Forward Mounted Commercial Window Over Continuous Insulation**



**Figure 42. Forward Mounted Commercial Window – Top View**

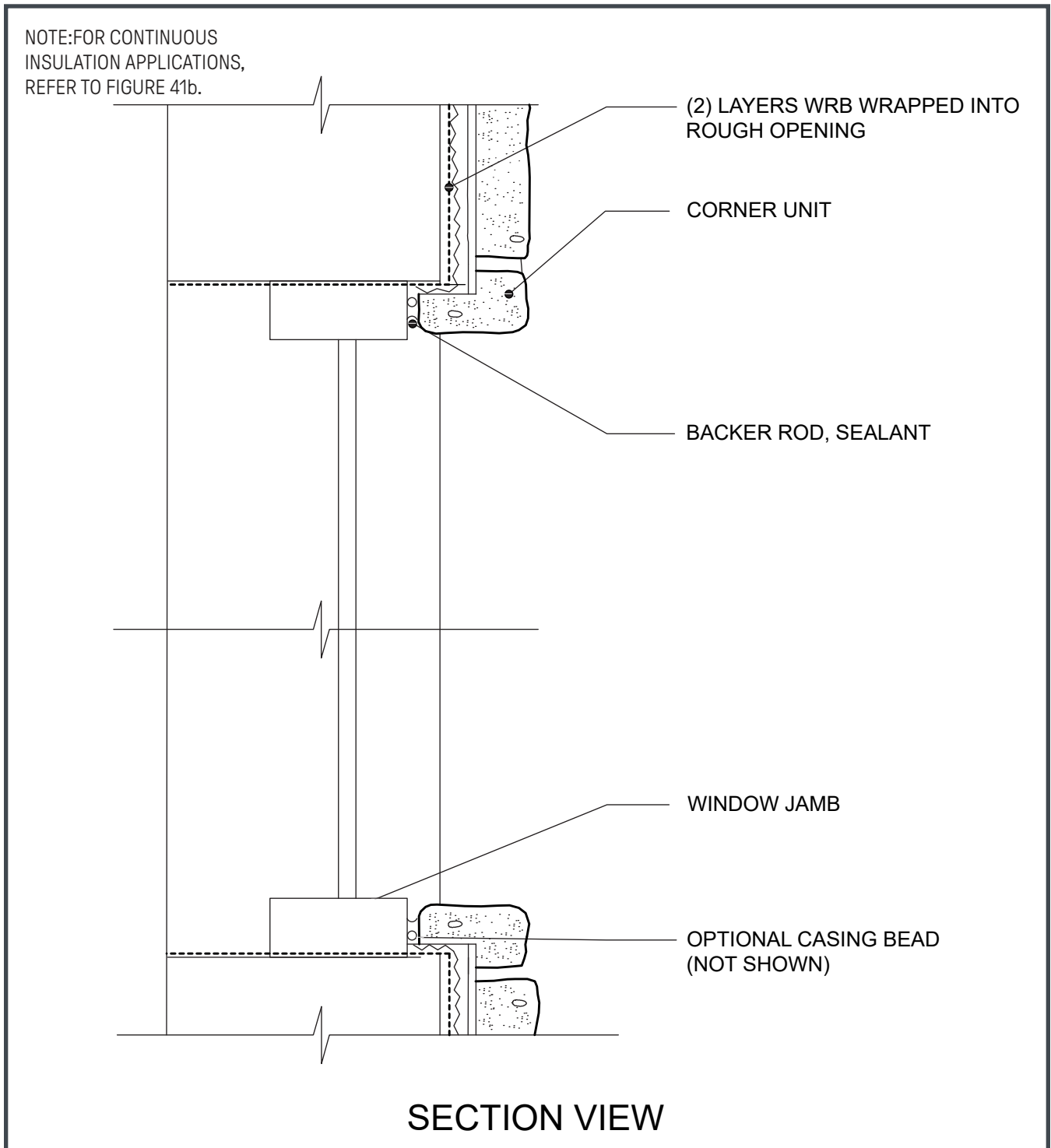
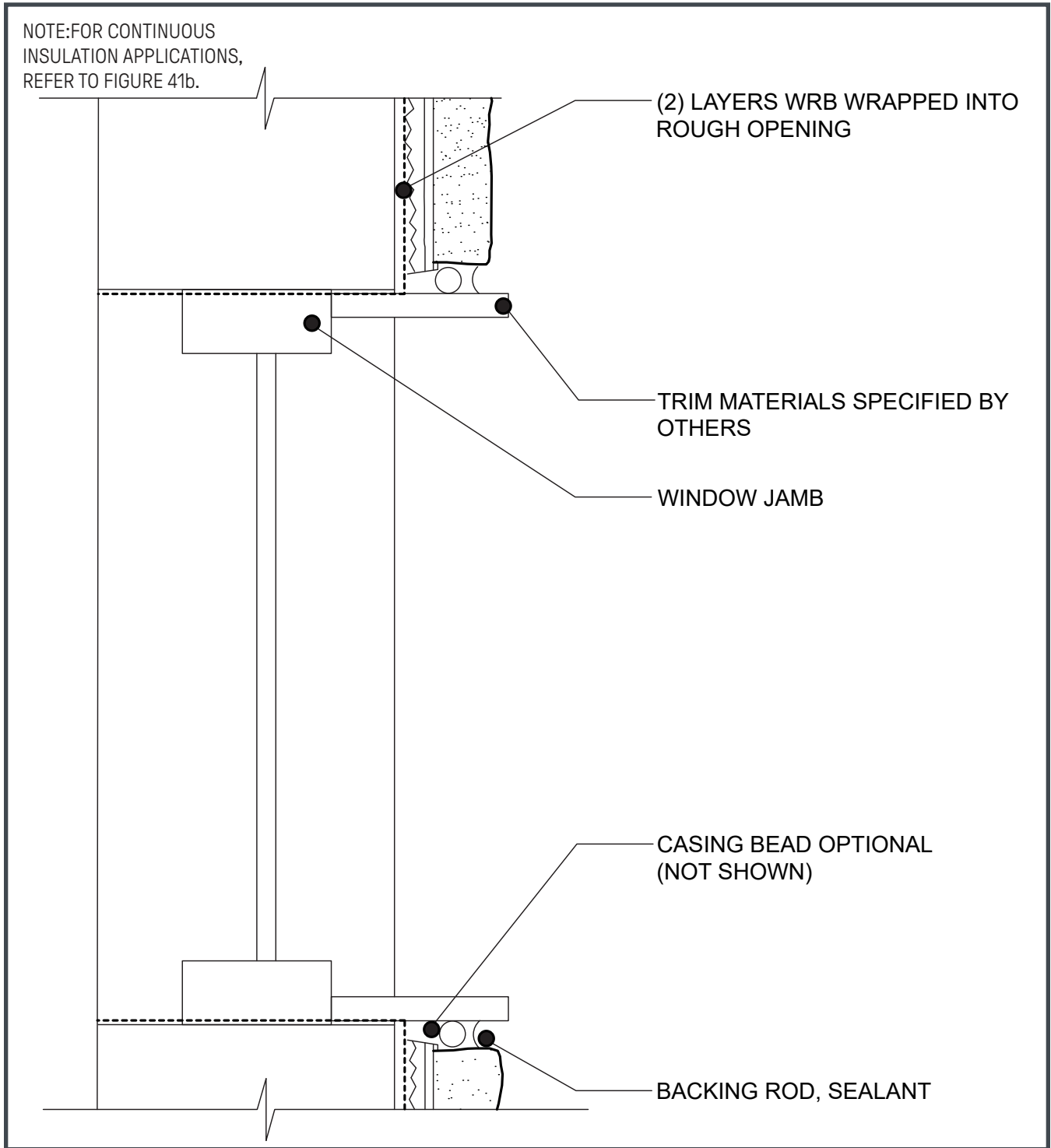
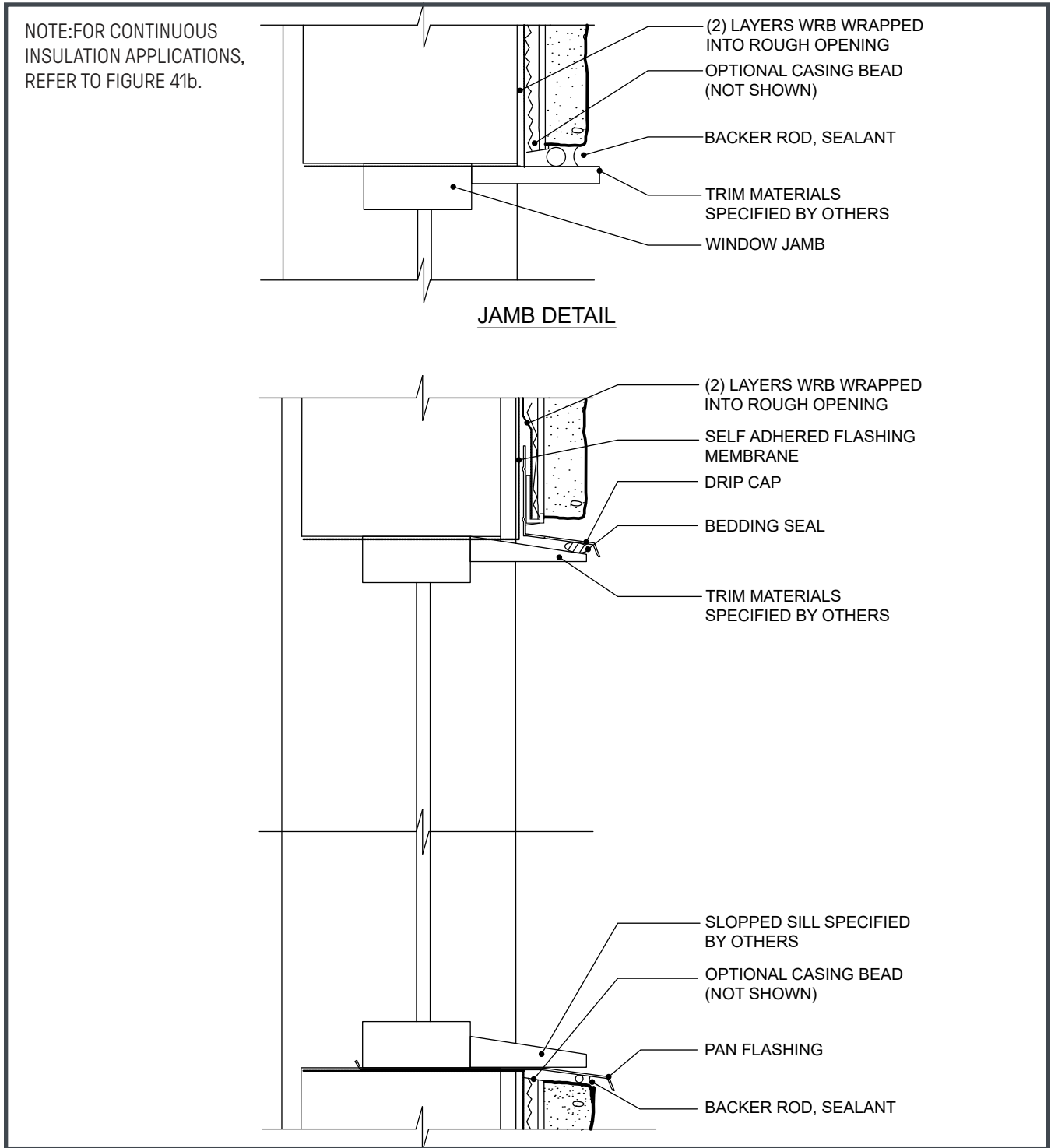


Figure 43. Commercial Storefront Window – Top View



**Figure 44. Commercial Storefront Window**





**Figure 45. Wall-Section Multi-Floor Joint Detail**

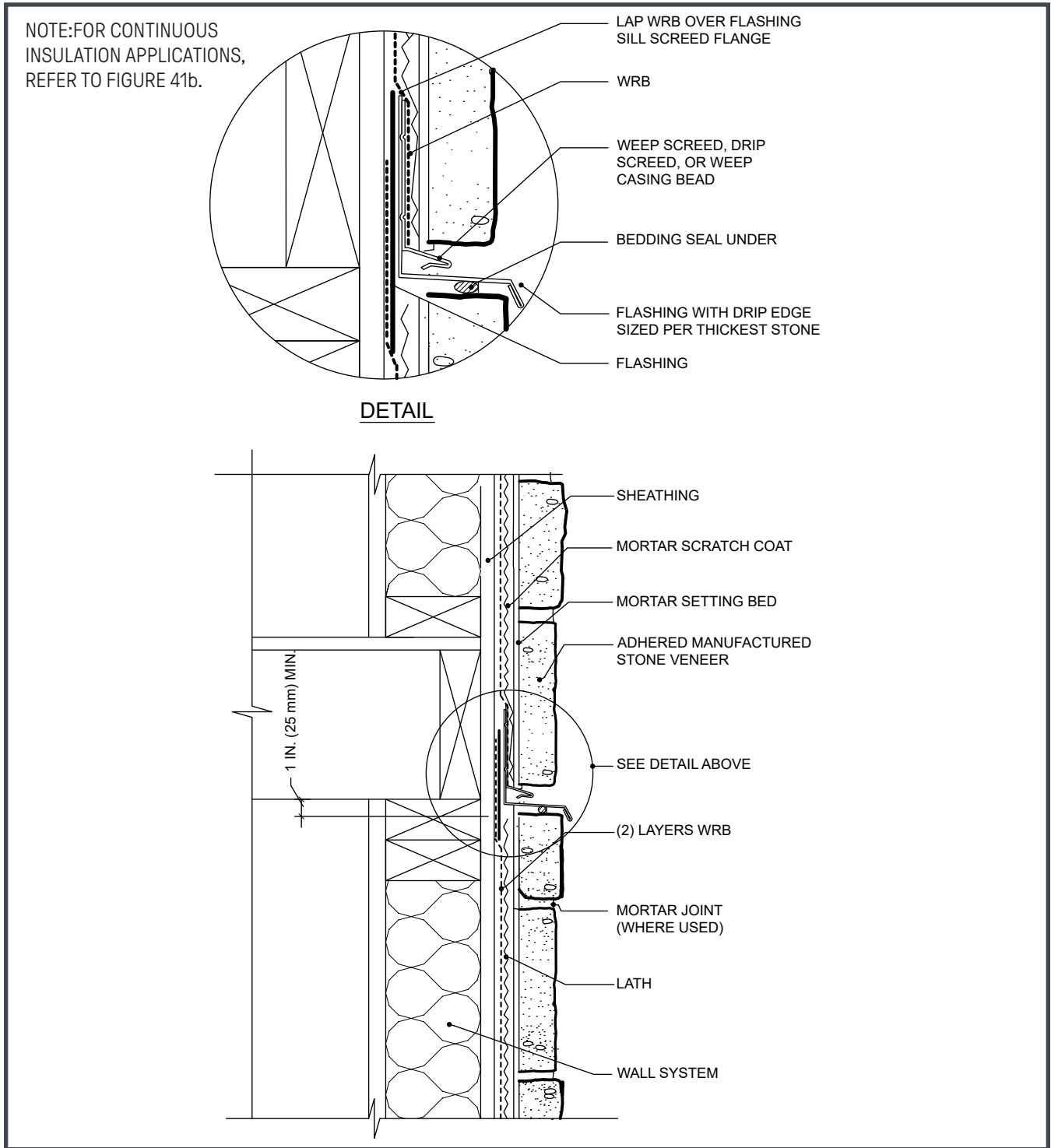


Figure 46a. Wall-Section CMU

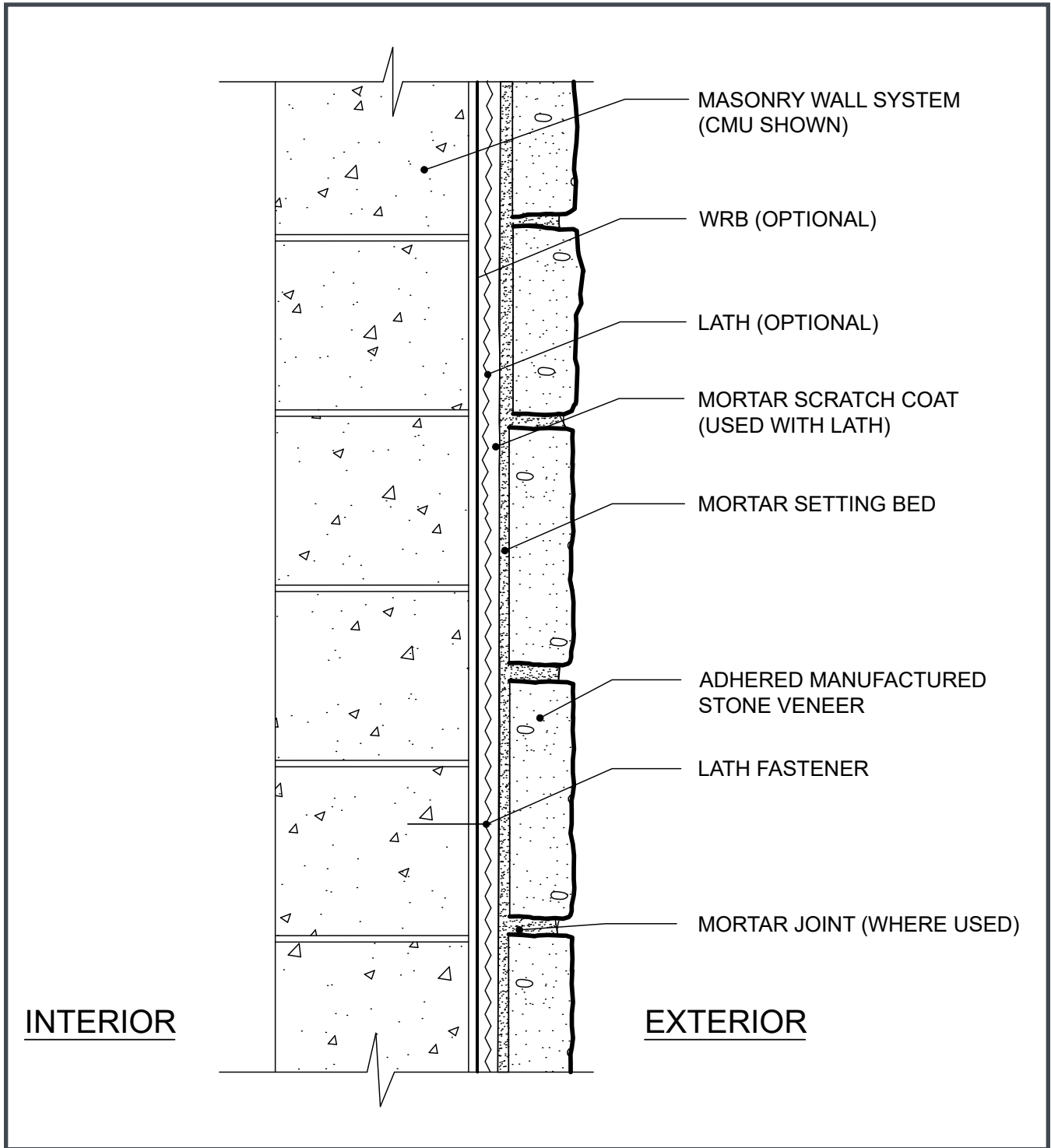
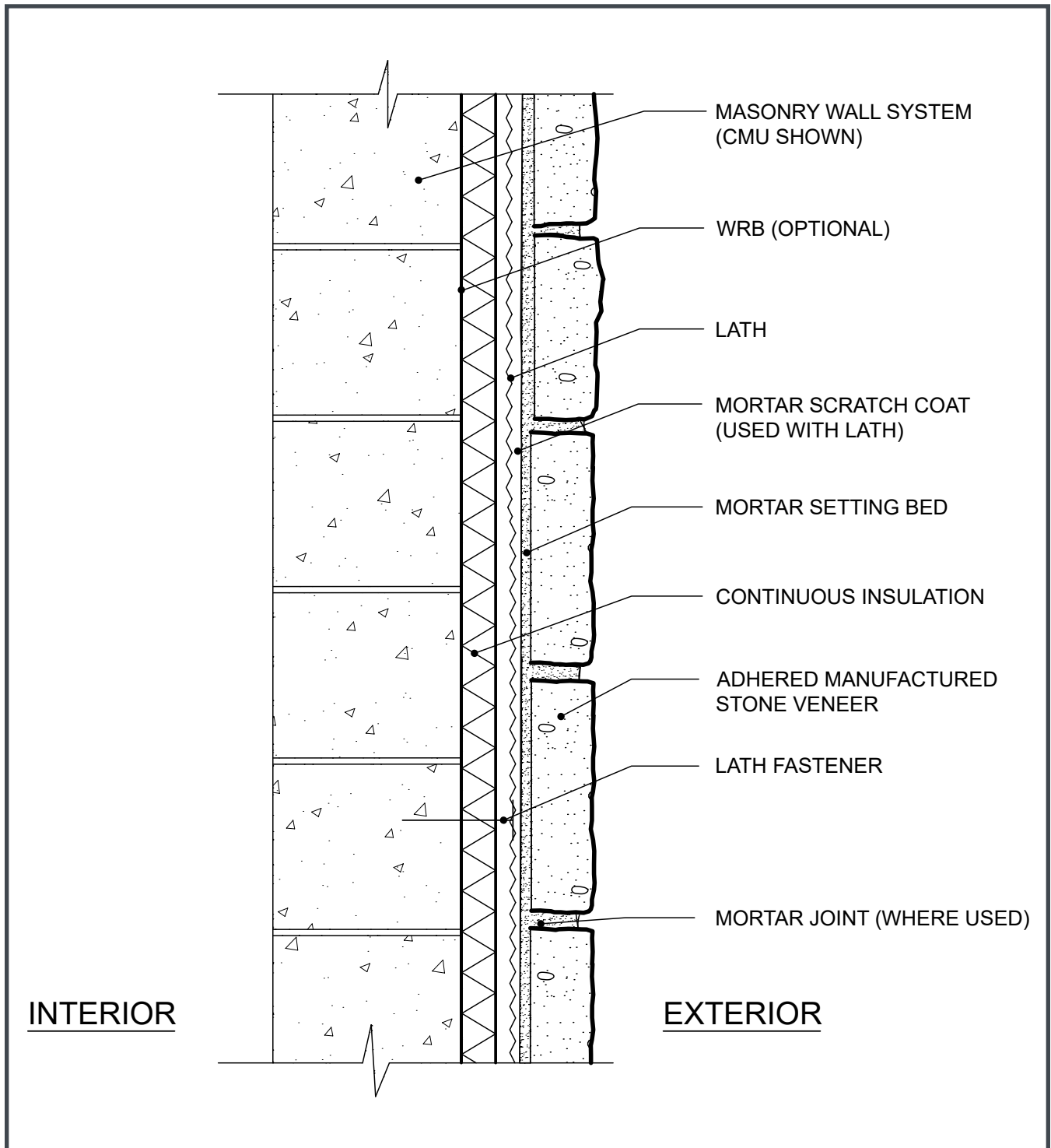
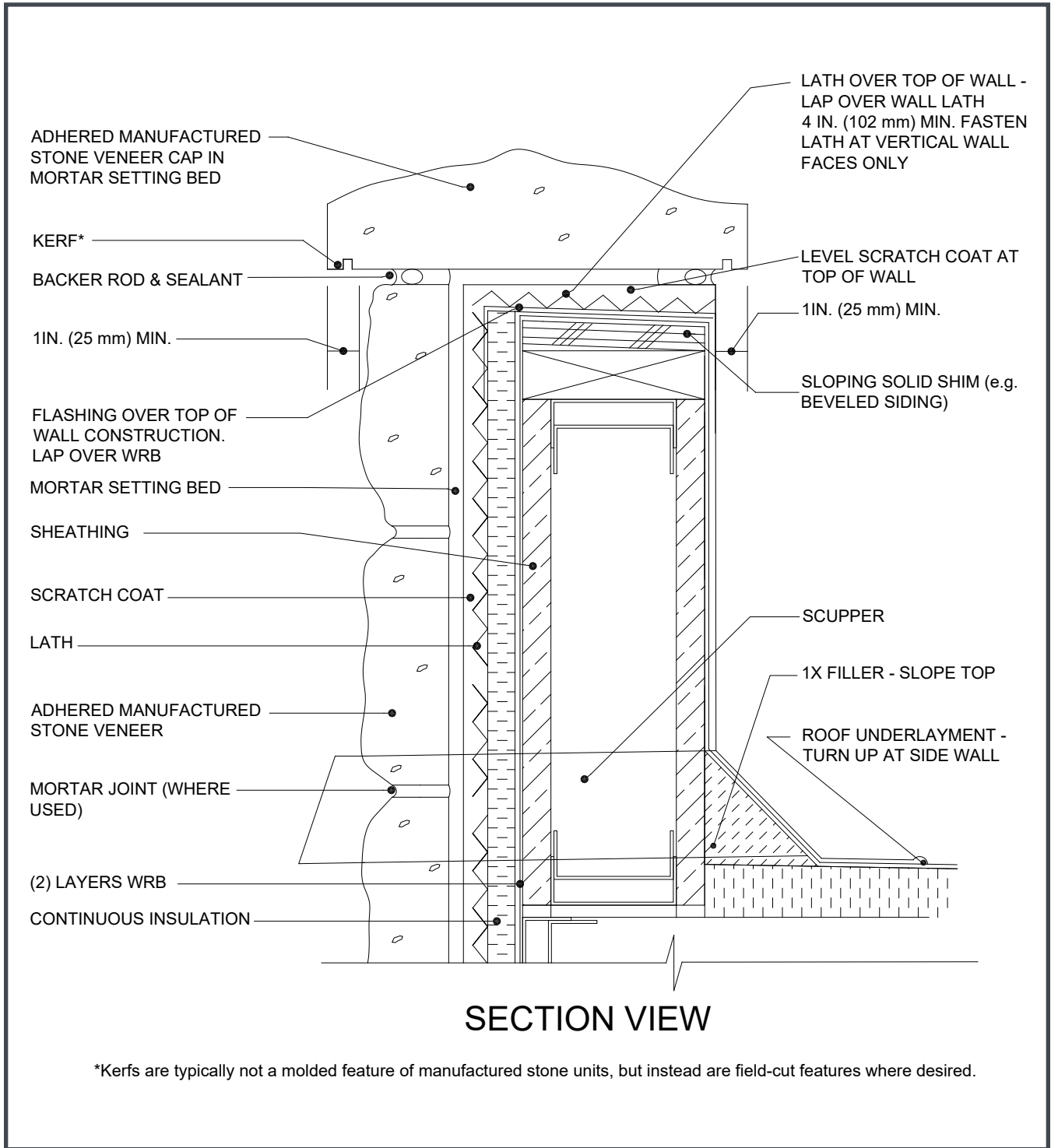


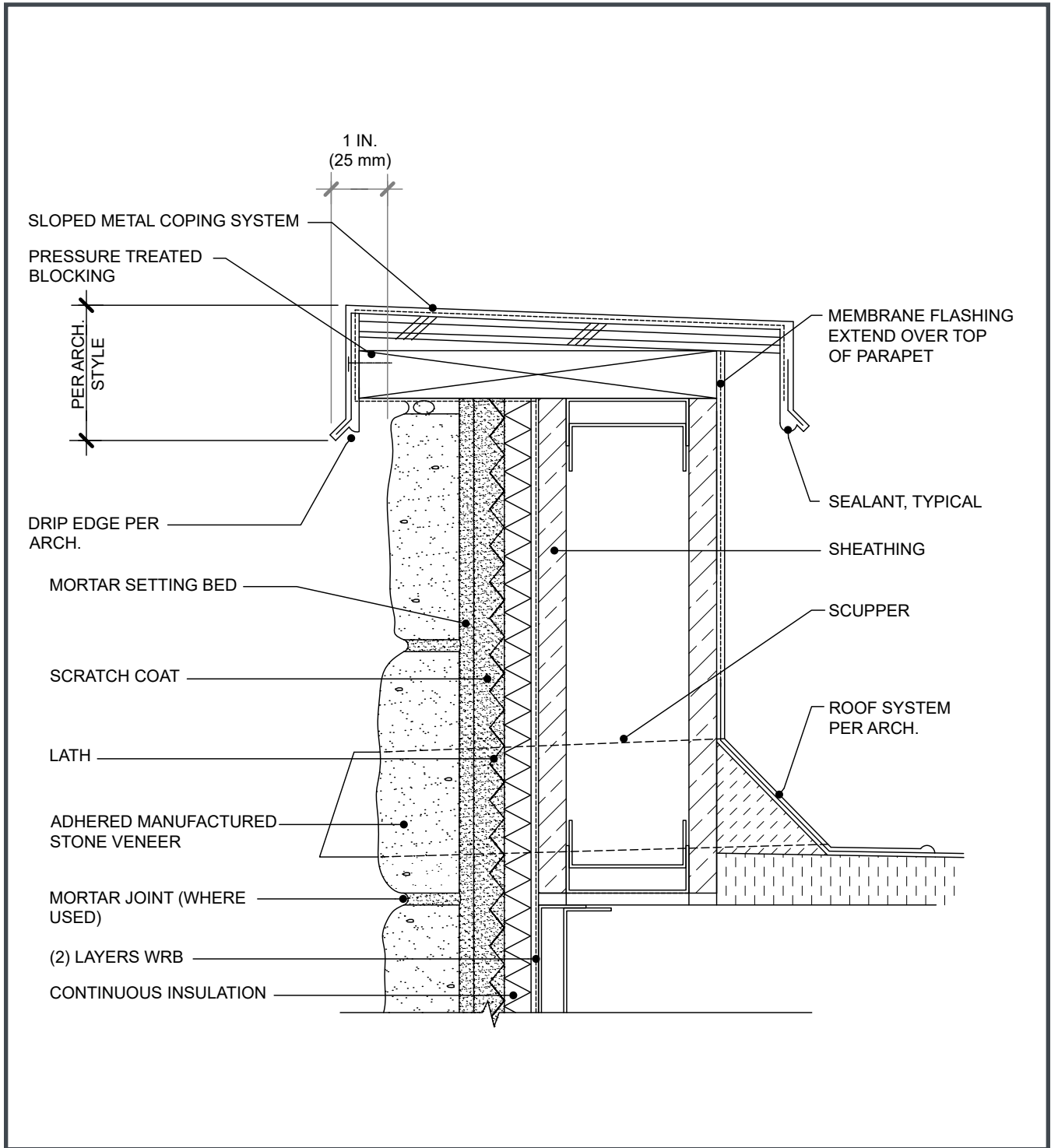
Figure 46b. Wall-Section Over Continuous Rigid Insulation



**Figure 47. Wall-Section Parapet with Stone Cap**



**Figure 48. Wall-Section Parapet with Steel Cap**







## NCMA Manufactured Stone Veneer Associate Members



ClarkDietrich Building Systems  
[www.clarkdietrich.com](http://www.clarkdietrich.com)



Dynamic Color Solutions  
[www.dynamiccolorsolutions.com](http://www.dynamiccolorsolutions.com)



Laticrete International Inc.  
<https://laticrete.com>

Globally Proven  
Construction Solutions



Masonry Adhered Veneer Systems (Omega Products International)  
[www.omegaproducts.com/mavs](http://www.omegaproducts.com/mavs)



Master Builders Solutions  
<https://www.master-builders-solutions.com/en-us>



PermaBase Cement Board (National Gypsum)  
[www.nationalgypsum.com](http://www.nationalgypsum.com)



Plastic Components Inc.  
<http://plasticcomponents.com>



Smooth-On, Inc.  
[www.smooth-on.com](http://www.smooth-on.com)



SPEC MIX, Inc.  
[www.specmix.com](http://www.specmix.com)



# NCMA MSV

MANUFACTURED STONE VENEER

For additional information or questions on the  
items contained here, please contact NCMA at:  
(703) 713-1900

Copyright © 2021 NCMA All Rights Reserved.  
NCMA and its respective logos are trademarks of  
NCMA in the United States and other countries.



Eldorado Stone, LLC
1370 Grand Ave., Bldg., B
San Marcos, CA 92069
Tel: (760) 736-3232
Fax: (760) 736-8890

e-mail: customerservice@westlake.net
website: www.eldoradostone.com

SECTION 04 73 00

MANUFACTURED MASONRY VENEER

GENERAL NOTES TO SPECIFIER:

THIS SPECIFICATION SECTION HAS BEEN PREPARED TO ASSIST DESIGN PROFESSIONALS IN THE PREPARATION OF PROJECT OR OFFICE MASTER SPECIFICATIONS. IT FOLLOWS GUIDELINES ESTABLISHED BY THE CONSTRUCTION SPECIFICATIONS INSTITUTE (CSI), AND THEREFORE MAY BE USED WITH MOST MASTER SPECIFICATION SYSTEMS WITH MINOR EDITING.

EDIT CAREFULLY TO SUIT PROJECT REQUIREMENTS. MODIFY AS NECESSARY AND DELETE ITEMS THAT ARE NOT APPLICABLE. VERIFY THAT REFERENCED SECTION NUMBERS AND TITLES ARE CORRECT. (NUMBERS AND TITLES REFERENCED ARE BASED ON MASTERFORMAT, 2004 EDITION).

THIS SECTION ASSUMES THE PROJECT MANUAL WILL CONTAIN COMPLETE DIVISION 1 DOCUMENTS INCLUDING SECTIONS 01 25 13-PRODUCT SUBSTITUTION PROCEDURES, 01 33 00-SUBMITTAL PROCEDURES, 01 62 00-PRODUCT OPTIONS, 01 66 00-PRODUCT STORAGE AND HANDLING REQUIREMENTS, 01 74 00-CLEANING AND WASTE MANAGEMENT, 01 77 00-CLOSEOUT PROCEDURES, AND 01 78 00-CLOSEOUT SUBMITTALS. CLOSE COORDINATION WITH DIVISION 1 SECTIONS IS REQUIRED. IF THE PROJECT MANUAL DOES NOT CONTAIN THESE SECTIONS, ADDITIONAL INFORMATION SHOULD BE INCLUDED UNDER THE APPROPRIATE ARTICLES.

THIS IS A CLOSED PROPRIETARY SPECIFICATION.

NOTES TO THE SPECIFIER ARE CONTAINED IN BOXES AND SHOULD BE DELETED FROM FINAL COPY.

GREY HIGHLIGHTED GREEN TEXT AND NOTES RELATE TO LEED® PROJECTS AND CAN BE DELETED IF THE PROJECT IS NOT INTENDED TO ATTAIN LEED® CERTIFICATION. CREDIT REFERENCES REFER TO LEED® FOR NEW CONSTRUCTION, V2.2.

OPTIONAL ITEMS REQUIRING SELECTION BY THE SPECIFIER ARE ENCLOSED WITHIN BRACKETS, E.G. [35] [40] [45]. MAKE APPROPRIATE SELECTIONS AND DELETE OTHERS.

ITEMS REQUIRING ADDITIONAL INFORMATION ARE UNDERLINED BLANK SPACES, E.G. \_\_\_\_\_ .

OPTIONAL PARAGRAPHS REQUIRING SELECTION OF ONE OF THE OPTIONS ARE SEPARATED BY "OR" WITHIN A BOX, E.G.

OR

BOLD FACE TEXT IDENTIFIES OPTIONAL PARAGRAPHS AND FEATURES THAT MAY BE INCLUDED OR DELETED DEPENDING ON PROJECT REQUIREMENTS. CONVERT THE BOLD FACE TEXT TO REGULAR TEXT WHEN INCLUDING THESE PARAGRAPHS OR FEATURES. WHEN DELETING A PARAGRAPH, BE CERTAIN THAT ALL SUBPARAGRAPHS ARE ALSO DELETED.

REVISE FOOTER TO SUIT PROJECT/OFFICE REQUIREMENTS.

ELECTRONIC VERSIONS OF THIS SPECIFICATION UTILIZE AUTOMATIC PARAGRAPH NUMBERING.

## PART 1 - GENERAL

### 1.01 SUMMARY

- A. Section Includes: Portland cement based manufactured [stone] [and] [brick] veneer and trim.
- B. Related Sections:

INCLUDE ALL DIVISION 01 SECTIONS CONTAINING LEED® REQUIREMENTS.

- 1. \_\_\_\_\_ - \_\_\_\_\_. **Wall Framing.**
- 2. \_\_\_\_\_ - \_\_\_\_\_. **Wall Sheathing.**
- 3. **07 60 00–Flashing and Sheet Metal.**
- 4. **07 92 00–Joint Sealants.**
- 5. **09 24 00–Portland Cement Plastering.**
- 6. **10 30 00–Fireplaces and Stoves.**

INCLUDE APPROPRIATE LANGUAGE BELOW IF PRODUCTS SPECIFIED IN THIS SECTION ARE TO BE BID AS ALTERNATES. OTHERWISE DELETE FOLLOWING PARAGRAPH.

#### C. Alternates:

- 1. Reference Section 01 23 00–Alternates.

### 1.02 REFERENCES

- A. American National Standards Institute (ANSI):
  - 1. ANSI A118.4 Specifications for Latex-Portland Cement Mortar.
- B. American Society for Testing and Materials (ASTM):
  - 1. ASTM C 39 – Standard Test Method for Compressive Strength of Cylindrical Concrete Specimens.
  - 2. ASTM C 67 – Standard Test Methods for Sampling and Testing Brick and Structural Clay Tile.
  - 3. ASTM C 144 – Standard Specification for Aggregate for Masonry Mortar.
  - 4. ASTM C 177 – Standard Test Method for Steady-State Head Flux Measurements and Thermal Transmission Properties by Means of the Guarded-Hot-Plate Apparatus.
  - 5. ASTM C 207 – Standard Specification for Hydrated Lime for Masonry Purposes.
  - 6. ASTM C 270 – Standard Specification for Mortar for Unit Masonry.
  - 7. ASTM C 482 – Standard Test Method for Bond Strength of Ceramic Tile to Portland Cement.
  - 8. ASTM C 567 – Standard Test Method for Determining Density of Structural Lightweight Concrete.
  - 9. ASTM C 847 – Standard Specification for Metal Lath.
  - 10. ASTM C 932 – Standard Specification for Surface-Applied Bonding Compounds for Exterior Plastering.
  - 11. ASTM C 979 – Standard Specification for Pigments for Integrally Colored Concrete.
  - 12. ASTM C 1032 – Standard Specification for Woven Wire Plaster Base.
  - 13. ASTM C 1059 – Standard Specification for Latex Agents for Bonding Fresh To Hardened Concrete.
  - 14. ASTM D 226 – Standard Specification for Asphalt-Saturated Organic Felt Used in Roofing and Waterproofing.

15. ASTM C1063 –Standard Specification for Installation of Lathing and Furring to Receive Interior and Exterior Portland Cement-Based Plaster
16. ASTM C1329 Standard specification for Portland cement
17. ASTM C578 – Standard Specification for Rigid, Cellular Polystyrene Thermal Insulation
18. ASTM C1289 – Standard Specification for Faced Rigid Cellular Polyisocyanurate Thermal Insulation Board
19. ASTM E2556/E2556M – Standard Specification for Vapor Permeable Flexible Sheet Water-Resistive Barriers Intended for Mechanical Attachment

C. Other Standards:

1. UBC Standard No. 14-1, Kraft Waterproof Building Paper
2. ICC AC38 Acceptance Criteria for Water Resistive Barriers
3. UU-B-790 Building Paper, Vegetable Based, Kraft , waterproofed, water repellent and fireproof

D. **City of Los Angeles: Research Report (LARR)**

1. Research Report #25589

E. International Code Council (ICC):

1. ESR Report.

F. **LEED®: US Green Building Council’s Leadership in Energy and Environmental Design Green Building Rating System™.**

G. Underwriter's Laboratory (UL): Building Materials Directory.

H. **US Department of Housing and Urban Development (HUD): Material Release Numbers 910Fs.**

1.03 SUBMITTALS

A. Reference Section 01 33 00–Submittal Procedures; submit following items:

1. Product Data.
2. Samples:
  - a. Standard sample board consisting of small-scale pieces of veneer units showing full range of textures and colors.
  - b. Full range of mortar colors.**
3. **Verification Samples: Following initial sample selection submit “laid-up” sample board using the selected stone and mortar materials and showing the full range of colors expected in the finished Work; minimum sample size: 3 by 3 feet (1 by 1 m).**
4. Quality Assurance/Control Submittals:
  - a. Qualifications:
    - 1) Proof of manufacturer qualifications.
    - 2) Proof of installer qualifications.
  - b. Regulatory Requirements: Evaluation reports.
  - c. Veneer manufacturer’s installation instructions.
  - d. Installation instructions for other materials.
5. **LEED® Submittals:**
  - a. **Credit MR 4.1, 4.2 Recycled Content: Provide percentage of recycled content (post- consumer and pre-consumer).**
  - b. **Credit MR 5.1, 5.2 Regional Materials:**

- 1) Provide distance between Project site and extraction site.
- 2) Provide distance between Project site and final manufacturing location.

MANUFACTURED MASONRY CAN ALSO CONTRIBUTE TO CREDIT EA 1 FOR OPTIMIZING ENERGY PERFORMANCE AND CREDITS ID 1.1-1.4 FOR INNOVATION IN DESIGN, HOWEVER, NO SPECIFIC SUBMITTALS ARE REQUIRED IN THIS SECTION.

- B. Closeout Submittals: Reference Section 01 78 00–Closeout Submittals; submit following items:
1. Maintenance Instructions.
  2. Special Warranties.

#### 1.04 QUALITY ASSURANCE

- A. Qualifications:
1. Manufacturer Qualifications: Eldorado Stone, LLC.
  2. Installer Qualifications: Experienced mason familiar with installation procedures and related local, state and federal codes masonry.

- B. Certifications:
1. **ICC Evaluation Service – Evaluation Report ESR-1215.**
  2. **ICC ESR-1215, Florida Building Code Supplement**
  3. **ASTM C1670**
  4. **LARR – Research Report RR25589**
  5. **HUD – Material Release Number 910F**
  6. **UL – Classification listing in Building Materials Directory: UL 546T (F8002).**

- C. Field Sample:

COMPLETE FOLLOWING SUBPARAGRAPH TO INCLUDE DESIRED DETAILS SUCH AS CORNERS, TRIM, MORTAR JOINTS AND JOINT DETAILS ABUTTING OTHER MATERIALS.

1. Prepare [4 by 4 foot (1200 by 1200 mm)] [ \_\_ by \_\_ foot ( \_\_\_\_ by \_\_\_\_ mm)] sample at a location on the structure as selected by the Architect. Use approved selection sample materials and colors. Include \_\_\_\_\_.
2. Obtain Architect’s approval.
3. Protect and retain sample as a basis for approval of completed manufactured stone work. Approved sample may be incorporated into completed work.

#### 1.05 DELIVERY, STORAGE, AND HANDLING

- A. Reference Section 01 66 00–Product Storage and Handling Requirements.
- B. Follow manufacturer’s instructions.

#### 1.06 PROJECT/SITE CONDITIONS

- A. Environmental Requirements: When air temperature is 40 degrees F (4.5 degrees C) or below, consult local building code for Cold-Weather Construction requirements.

#### 1.07 WARRANTY

- A. Special Warranty: Manufacturer’s standard warranty coverage against defects in materials when installed in accordance with manufacturer’s installation instructions.

## PART 2 - PRODUCTS

### 2.01 MANUFACTURER

A. Eldorado Stone, LLC  
1370 Grand Ave., Bldg. B  
San Marcos, CA 92069

Tel: (800) 925-1491  
Fax: (760) 736-3840  
E-Mail: [customerservice@westlake.net](mailto:customerservice@westlake.net)  
Website: [www.eldoradostone.com](http://www.eldoradostone.com)

INSERT NAME, ADDRESS AND CONTACT INFORMATION OF LOCAL DISTRIBUTOR BELOW.

#### 1. Manufacturer's Distributor:

IF PROJECT UTILIZES ONLY ONE TYPE OF STONE, INSERT THE NAME OF THE PRODUCT IN THE BLANK SPACE BELOW AND DELETE THE SECOND SELECTION. IF MORE THAN ONE TYPE OF STONE IS REQUIRED, DELETE THE FIRST SELECTION AND VERIFY THAT STONE TYPES ARE NOTED ON DRAWINGS.

B. Product: [ \_\_\_\_\_ veneer ] [ Veneer types as shown on Drawings ].

C. Substitutions: None Allowed.

### 2.02 MATERIALS

#### A. Stone Veneer:

SELECT DESIRED PROFILE FROM THE ELDORADO STONE WEBSITE [STONE](#) PAGE. INSERT PROFILE BELOW.

1. Profile: \_\_\_\_\_ . Include matching corner pieces.

SELECT DESIRED STONE ACCENTS FROM THE ELDORADO STONE WEBSITE [ACCENTS](#) PAGE. INSERT DESIRED ACCENTS BELOW AND INSERT TEXTURE IF REQUIRED. VERIFY THAT DIMENSIONS, IF REQUIRED, ARE SHOWN ON THE DRAWINGS.

2. **Stone Accents:** \_\_\_\_\_ .
- Color: [ Buckskin ] [ Earth ] [ Smoke ] [ Taupe ] [ As shown on Drawings ].
  - Texture: \_\_\_\_\_ .

#### B. Brick Veneer:

SELECT DESIRED PROFILE AND COLOR FROM THE ELDORADO STONE WEBSITE [BRICK](#) PAGE; INSERT PROFILE AND COLOR BELOW.

1. Profile: \_\_\_\_\_ . Include matching corner pieces.
- Color: \_\_\_\_\_ .

SELECT DESIRED BRICK ACCENTS FROM THE ELDORADO STONE WEBSITE [ACCENTS](#) PAGE. INSERT DESIRED ACCENTS BELOW AND INSERT TEXTURE IF REQUIRED. VERIFY THAT DIMENSIONS, IF REQUIRED, ARE SHOWN ON THE DRAWINGS.

2. **Brick Accents:** \_\_\_\_\_ .
- Color: [ Match brick ] [ \_\_\_\_\_ ] [ As shown on Drawings ].

- C. Veneer Unit properties: Precast veneer units consisting of portland cement, lightweight aggregates, and mineral oxide pigments.
  - 1. Compressive Strength: ASTM C 192 and ASTM C 39, 5 sample average: greater than 1,800 psi (12.4MPa).
  - 2. Shear Bond: ASTM C 482: 50 psi (345kPa), minimum.
  - 3. Freeze-Thaw Test: ASTM C 67: Less than 3 percent weight loss and no disintegration.
  - 4. Thermal Resistance: ASTM C 177: 0.473 at 1.387 inches thick
  - 5. Weight per square foot: 2012 IBC and 2012 IRC, ASTM C1670, 15 pounds, saturated.

EDIT MATERIALS PER BUILDING CODE REQUIREMENTS. DELETE FROM THIS SECTION IF SPECIFIED IN OTHER SECTIONS.

- D. Weather Barrier: [ASTM D 226, Type 1, No. 15, non-perforated asphalt-saturated felt paper] [UBC Standard 14-1, kraft waterproof building paper] or [UBC Standard No. 14-1, Kraft Waterproof Building Paper] or [ICC AC-38, synthetic house wrap]
- E. Reinforcing: [ASTM C 847, 2.5lb/yd<sup>2</sup> (1.4kg/m<sup>2</sup>) galvanized expanded metal lath] [ASTM C 847, 3.4lb (1.8 kg/m<sup>2</sup>) galvanized 3/8" rib lath] [ASTM C 1032, 17 gauge (1.3 mm) woven wire mesh] complying with code agency requirements for the type of substrate over which stone veneer is installed.
- F. Mortar:
  - 1. Cement: Portland cement complying with ASTM C 1329.
  - 2. Lime: ASTM C 207.
  - 3. Sand: ASTM C 144, natural or manufactured sand.
  - 4. **Color Pigment: ASTM C 979, mineral oxide pigments.**
  - 5. Water: Potable.
  - 6. Pre-Packaged Latex-Portland Cement Mortar: ANSI A118.4.
- G. Bonding Agent: Exterior integral bonding agent meeting [ASTM C 932] [ASTM C 1059 Type II]
- H. Water Repellent: Water based silane or siloxane masonry water repellent**

2.03 MORTAR MIXES

- A. Standard Installation (Grouted Joints):
  - 1. Mix mortar in accordance with ASTM C 270,
  - 2. Polymer modified mortar complying with ANSI A118.4
    - a. **Add color pigment in grout joint mortar in accordance with pigment manufacturer's instructions not to exceed 10% by weight of cement.**

OR

- A. Jointless/Dry-Stacked Installation:
  - 1. Polymer modified mortar complying with ANSI A118.4
  - 2. Mortar prepared to comply with ASTM C270. Type S mortar.
    - a. **Add color pigment in accordance with pigment manufacturer's instructions.**

## **PART 3 - EXECUTION**

### 3.01 EXAMINATION

- A. Examine substrates upon which work will be installed.
- B. Coordinate with responsible entity to perform corrective work on unsatisfactory substrates.
- C. Commencement of work by installer is acceptance of substrate.

### 3.02 PREPARATION

- A. Protection: Protect adjacent work from contact with mortar.
- B. Surface Preparation: Prepare substrate in accordance with manufacturer's installation instructions for the type of substrate being covered.

### 3.03 INSTALLATION

- A. Install and clean stone in accordance with manufacturer's installation instructions for Standard Installation (Grouted Joint) or Jointless/Dry-Stacked installation as specified above.
- B. Apply repellent in accordance with repellent manufacturer's application instructions.**

### 3.04 FIELD QUALITY CONTROL

- A. Manufacturer's Field Services: Manufacturer's Field Service Representative shall make [one] [two] [ \_\_\_\_\_ ] periodic site visits review of on-going installation process but is not responsible for any errors or omissions that are not observed or are previously completed.**

### 3.05 CLEANING

- A. Reference Section 01 74 00–Cleaning and Waste Management.
- B. Remove protective coverings from adjacent work.
- C. Cleaning Veneer Units:
  - 1. Wash with soft bristle brush and water/granulated detergent solution
  - 2. Rinse immediately with clean water
- D. Removing Efflorescence:
  - 1. Allow veneer to dry thoroughly
  - 2. Scrub with soft bristle brush and clean water
  - 3. Rinse immediately with clean water; allow to dry
  - 4. If efflorescence is still visible, contact ES Customer Service for assistance

END OF SECTION<sup>1</sup>

---

<sup>1</sup> This specification was prepared specifically for Eldorado Stone Corporation by ASC Specification Consultants. Comments or suggestions for improvement should be addressed to Eldorado Stone via the contact information on page one.



# ICC-ES Evaluation Report

**ESR-1215**

Reissued November 2023

This report also contains:


- CBC Supplement

Subject to renewal November 2024

- FBC Supplement

ICC-ES Evaluation Reports are not to be construed as representing aesthetics or any other attributes not specifically addressed, nor are they to be construed as an endorsement of the subject of the report or a recommendation for its use. There is no warranty by ICC Evaluation Service, LLC, express or implied, as to any finding or other matter in this report, or as to any product covered by the report.

Copyright © 2023 ICC Evaluation Service, LLC. All rights reserved.

<p><b>DIVISION: 04 00 00— MASONRY</b></p> <p><b>Section: 04 71 00— Manufactured Brick Masonry</b></p> <p><b>Section: 04 73 00— Manufactured Stone Masonry</b></p>	<p><b>REPORT HOLDER: WESTLAKE ROYAL STONE, LLC</b></p>	<p><b>EVALUATION SUBJECT: ELDORADO STONE®, ELDORADO BRICK®, AND ELDORADO ADOBE® VENEERS</b></p>	
---	--	---	---

## 1.0 EVALUATION SCOPE

### 1.1 Compliance with the following codes:

- 2015 [International Building Code® \(IBC\)](#)
- 2015 [International Residential Code® \(IRC\)](#)
- Other Codes (see Section 8.0)

### Properties evaluated:

- Veneer strength and durability
- Surface burning characteristics
- Thermal Resistance

### 1.2 Evaluation to the following green code(s) and/or standards:

- 2020, and 2019 [California Green Building Standards Code \(CALGreen\)](#), Title 24, Part 11
- 2020, 2015, 2012 and 2008 [ICC 700 National Green Building Standard™](#) (ICC 700-2015, ICC 700-2012, and ICC 700-2008)

### Attributes verified:

See Section 3.0

## 2.0 USES

Eldorado Stone, Eldorado Brick and Eldorado Adobe Veneers are used as adhered, non-load-bearing exterior veneers or interior finishes on wood or light gage steel stud walls, concrete walls, or concrete masonry walls.

## 3.0 DESCRIPTION

Eldorado Stone®, Eldorado Brick® and Eldorado Adobe® veneers are precast concrete products made to resemble natural stone, brick, or adobe, respectively, in color and in texture. The concrete is composed of cement, aggregate, water, admixtures, and coloring. The veneer units are molded and cured at the plant. The average saturated weight of the installed veneer units does not exceed 15 pounds per square foot (73.2 kg/m<sup>2</sup>). Evaluated patterns of veneer are listed in [Table 1](#).

The precast veneer has a Class A finish rating in accordance with IBC Section 803.1.1 and complies with the flame-spread and smoke-development requirements of IRC Section R302.9. The stone veneer has an *R*-value of 0.43 when tested in accordance with ASTM C177 at an average thickness of 1.5 inches (38 mm).

The attributes of the precast veneers have been verified as conforming to the provisions of (i) CALGreen Section A4.405.1.3 for prefinished building materials and Section A5.406.1.2 for reduced maintenance; (ii) ICC 700-2020 Section 602.1.6 and 11.602.1.6 for termite-resistance materials and Sections 601.7 and 11.601.7 for site-applied finishing materials, (iii) ICC 700-2015 and ICC 700-2012 Sections 602.1.6 and 11.602.1.6 for termite-resistant materials and Sections 601.7, 11.601.7, and 12.1(A).601.7 for site-applied finishing materials; and (iv) ICC 700-2008 Section 602.8 for termite-resistant materials and Section 601.7 for site-applied finishing materials. Note that decisions on compliance for those areas rest with the user of this report. The user is advised of the project-specific provisions that may be contingent upon meeting specific conditions, and the verification of those conditions is outside the scope of this report. These codes or standards often provide supplemental information as guidance.

## 4.0 INSTALLATION

### 4.1 General:

Installation of Eldorado Stone precast stone veneer must comply with this report, the manufacturer's published installation instructions, and the applicable code. The manufacturer's published installation instructions must be available at the jobsite at all times during installation. The veneer must be installed in accordance with the clearance requirements of IBC Section 1405.10.1.3 or IRC Section R703.12.1, as applicable. The veneer has been evaluated for application over backings of cement plaster, concrete or concrete masonry.

### 4.2 Preparation of Backing:

**4.2.1 Cement Plaster Backings:** Cement plaster backings may be applied over plywood, OSB or gypsum sheathing, supported by wood or steel studs; over open wood or steel studs; over concrete walls; and over concrete masonry walls, when installed as described in Sections 4.2.1.1 and 4.2.1.2.

**4.2.1.1 Installation over Studs:** For exterior installations, the cement plaster backing must be installed over a water-resistive barrier complying with IBC Section 1405.10.1.1 or IRC Section R703.12.3, as applicable. Also, flashing must be installed as required by IBC Section 1405.10.1.2 or IRC Sections R703.4 and R703.12.2, as applicable, and weep screeds must be installed at the bottom of the stone veneer. The weep screeds must comply with, and be installed in accordance with, IBC Section 1405.10.1.2.1 or IRC Section R703.12.2, as applicable. In addition, the weep screeds must have holes with a minimum diameter of  $\frac{3}{16}$  inch (4.8 mm) spaced at a maximum of 33 inches (838 mm) on center, as required by Section 12.1.6.2 of TMS 402/ACI 530/ASCE 5, which is referenced in IBC Section 1405.10.

Studs must be spaced no more than 16 inches (406 mm) on center. Lath must be a 2.5 lb/yd<sup>2</sup> (1.4 kg/m<sup>2</sup>) diamond mesh metal lath conforming to ASTM C847; a 3.4 lb/yd<sup>2</sup> (1.8 kg/m<sup>2</sup>),  $\frac{3}{8}$ -inch thick ribbed lath conforming to ASTM C847; a 1.4 lb/yd<sup>2</sup> (0.760 kg/m<sup>2</sup>) galvanized woven wire mesh conforming to ASTM C1032; a welded wire lath complying with ASTM C933; or lath addressed in an ICC-ES evaluation report as a substitute for lath complying with ASTM C847. Lath may be self-furred or non-furred, provided furring or furring fasteners are used. When the cement plaster backing is installed over open studs, a paper back lath must be used. All lath must be installed over the water-resistive barriers by following lath manufacturer's installation guidelines and recommendations. Lath or mesh must be fastened to each of the wall studs as required by ASTM C1063 and IRC section R703.7.1. Fasteners must be spaced a maximum of 6 inches (153 mm) on center.

For attaching lath to wood studs, fasteners must be galvanized nails having a minimum shank diameter of 0.120-inch, a minimum head diameter of  $\frac{7}{16}$ -inch (11.1 mm) and sufficient length to penetrate the studs a minimum of  $\frac{3}{4}$ -inch (19.1 mm); wood screws of sufficient length to penetrate a minimum of  $\frac{5}{8}$  inch (15.9 mm) into the studs; or minimum 16 gage staples with a crown width of  $\frac{3}{4}$  inch (19.1 mm) and sufficient length to penetrate the studs a minimum of  $\frac{3}{4}$  inch (19.1 mm). Wood studs must have a minimum specific gravity of 0.42. For attaching lath to steel studs, fasteners must be a minimum of #12 corrosion resistant pan head or pancake head self-drilling, tapping screws having sufficient length to protrude a minimum of  $\frac{3}{8}$  inch (9.5 mm) through the stud. Steel studs must be a minimum of 33 mils thick.

A scratch coat of Type N or S mortar (cement plaster) complying with ASTM C926 must be applied over the lath to a thickness of  $\frac{1}{2}$  inch to  $\frac{3}{4}$  inch (12.7 to 19.1 mm). The scratch coat must be scored horizontally in accordance with the manufacturer's published installation instructions and must be allowed to cure in accordance with IBC Section 2512.6, prior to the application of the veneer units.

**4.2.1.2 Installation over Concrete and Masonry:** The veneer units may be applied directly to concrete and masonry backing without lath, provided the concrete and masonry surface is clean and free of paints, repellents, contaminants and release agents (see Section 4.2.2). Where lath is used, apply one layer of water-resistive barrier over the wall, in accordance with the report holder's recommendations. The lath must be corrosion-resistant metal lath complying with ASTM C847, or 1.4 lb/yd<sup>2</sup> (0.760 kg/m<sup>2</sup>), corrosion-resistant, woven wire plaster base complying with ASTM C1032. The lath must be fastened to the wall in accordance with Section 7.10 of ASTM C1063, and IRC Section R703.6.1, as applicable. The fasteners must be spaced a maximum of 6 inches (152 mm) on center vertically and 16 inches (406 mm) on center horizontally. The gravity load (shear) capacity and negative wind load (pull-out) capacity of the proprietary fasteners must be justified to the satisfaction of the code official. The scratch coat must be applied as described in Section 4.2.1.1.

**4.2.2 Concrete and Masonry Backing:** Concrete masonry and poured concrete wall surfaces must be prepared in accordance with Section 5.2 of ASTM C926, and IBC Section 2510.7, as applicable. Alternatively, a cement plaster backing may be installed as described in Section 4.2.1.

#### **4.3 Application of Veneer Units:**

Prior to the application of the veneer units, the scratch coat or other backing and the back of the veneer units must be moistened in accordance with the manufacturer's instructions. Veneer units must be installed in accordance with IBC Section 1405.10.1.4.3. Under the IRC, a minimum 1/2-inch-thick (12.7 mm) setting bed of Type N or S mortar must be applied to the back of the veneer units, and the veneer units must be pressed firmly in place, squeezing the mortar out around all veneer unit edges. For grouted patterns, joints between veneer units must be grouted and tooled in accordance with the veneer manufacturer's published installation instructions.

## **5.0 CONDITIONS OF USE:**

The precast stone veneer described in this report complies with, or is a suitable alternative to what is specified in, those codes listed in Section 1.0 of this report, subject to the following conditions:

- 5.1** Installation must comply with this report, the manufacturer's published installation instructions and the applicable code. In the event of a conflict between the manufacturer's published installation instructions and this report, this report governs.
- 5.2** The use of the precast stone veneer has been evaluated for installation on walls with cement plaster, concrete or concrete masonry backings.
- 5.3** Expansion or control joints, used to limit the effect of differential movement of supports on the veneer system, are to be specified by the architect, designer or veneer manufacturer, in that order. Consideration must also be given to movement caused by temperature change, shrinkage, creep and deflection.
- 5.4** In jurisdictions adopting the IBC, the supporting wall must be designed to support the installed weight of the veneer system, including veneer, setting bed and cement plaster backing, as applicable. At wall openings, the supporting members must be designed to limit deflection to 1/600 of the span of the supporting members.
- 5.5** In jurisdictions adopting the IRC, where the seismic provisions of IRC Section R301.2.2 apply, the average weight of the wall supporting the precast stone veneer, including the weight of the veneer system, must be determined. When this weight exceeds the applicable limits of IRC Section R301.2.2.2.1, an engineered design of the wall construction must be performed in accordance with IRC Section R301.1.3.
- 5.6** Eldorado Stone products are manufactured under a quality control program with inspections by ICC-ES.

## **6.0 EVIDENCE SUBMITTED**

- 6.1** Data in accordance with the [ICC-ES Acceptance Criteria for Precast Stone Veneer \(AC51\)](#), dated June 2013 (editorially revised September 2014).
- 6.2** Report of testing of surface-burning characteristics in accordance with ASTM E84.
- 6.3** Report of testing on thermal resistance in accordance with ASTM C177.

## **7.0 IDENTIFICATION**

- 7.1** Boxes of precast stone veneer units are identified with the manufacturer's name (Westlake Royal Stone), the brand name (Eldorado Stone), the pattern name, the manufacturing date and location, and the evaluation report number (ESR-1215).

7.2 The report holder's contact information is the following:

**WESTLAKE ROYAL STONE LLC**  
**2801 POST OAK BOULEVARD, SUITE 600**  
**HOUSTON, TEXAS 77056**  
**(855) 769-2585**  
[www.royalbuildingproducts.com/boral](http://www.royalbuildingproducts.com/boral)

## 8.0 OTHER CODES

### 8.1 Evaluation Scope:

In addition to the codes referenced in Section 1.0, the products described in this report were evaluated for compliance with the following codes:

- 2012 *International Building Code*<sup>®</sup> (2012 IBC)
- 2012 *International Residential Code*<sup>®</sup> (2012 IRC)
- 2009 *International Building Code*<sup>®</sup> (2009 IBC)
- 2009 *International Residential Code*<sup>®</sup> (2009 IRC)
- 2006 *International Building Code*<sup>®</sup> (2006 IBC)
- 2006 *International Residential Code*<sup>®</sup> (2006 IRC)
- 2013 *Abu Dhabi International Building Code* (ADIBC)<sup>†</sup>

<sup>†</sup>The ADIBC is based on the 2009 IBC. 2009 IBC code sections referenced in this report are the same sections in the ADIBC.

The Eldorado Stone products described in this report comply with, or are suitable alternatives to what is specified in, the codes listed above, subject to the provisions of Sections 8.2 through 8.7.

### 8.2 Uses:

See Section 2.0.

### 8.3 Description:

See the first paragraph of Section 3.0 and the following: The precast veneer has a Class A finish rating in accordance with 2012 and 2009 IBC Section 803.1.1 (2006 IBC Section 803.1) and complies with the flame-spread and smoke-development requirements of 2012 and 2009 IRC Section R302.9 (2006 IRC Section R315). The stone veneer has an *R*-value of 0.43 when tested in accordance with ASTM C177 at an average thickness of 1.5 inches (38 mm).

### 8.4 Installation:

**8.4.1 General:** See Section 4.1, and the following: Under the 2012 IBC and 2012 IRC, the veneer must be installed in accordance with the clearance requirements of 2012 IBC Section 1405.10.1.3 and 2012 IRC Section R703.12.1, as applicable.

#### 8.4.2 Preparation of Backing:

**8.4.2.1 Cement Plaster Backings:** See Section 4.2.1.

**8.4.2.1.1 Installation over Studs:** Replace the first paragraph of Section 4.2.1.1 with the following: For exterior installations, the cement plaster backing must be installed over a water-resistive barrier complying with 2012 IBC Section 1405.10.1.1.; 2009 and 2006 IBC Sections 1404.2 and 2510.6; or 2012, 2009 and 2006 IRC Sections R703.2 and R703.6.3, as applicable. Also, flashing must be installed as required by 2012 IBC Sections 1405.4 and 1405.10.1.2; 2009 IBC Section 1405.4; 2006 IBC Section 1405.3; or 2012, 2009 and 2006 IRC Section R703.8, as applicable, and weep screeds must be installed at the bottom of the stone veneer. The weep screeds must comply with, and be installed in accordance with, 2012 IBC Section 1405.10.1.2; 2009 and 2006 IBC Section 2512.1.2; 2012 IRC Section R703.12.2; or 2009 and 2006 IRC Section R703.6.2.1, as applicable. In addition, the weep screeds must have holes with a minimum diameter of  $\frac{3}{16}$  inch (4.8 mm) spaced at a maximum of 33 inches (838 mm) on center, as required by Section 6.1.6.2 of TMS 402-11, which is referenced in 2012 IBC Section 1405.10; Section 6.1.5.2 of TMS 402-08, which is referenced in 2009 IBC Section 1405.10; or Section 6.1.5.2 of ACI 530-05, which is referenced in 2006 IBC Section 1405.9, as applicable.

For additional requirements, see the remaining paragraphs of Section 4.2.1.1.

**8.4.2.1.2 Installation over Concrete and Masonry:** See Section 4.2.1.2.

**8.4.2.2 Concrete and Masonry Backing:** See Section 4.2.2.

**8.4.3 Application of Veneer Units:** See Section 4.3.

**8.5 Conditions of Use:**

See Section 5.0.

**8.6 Evidence Submitted:**

See Section 6.0.

**8.7 Identification:**

See Section 7.0.

**TABLE 1—EVALUATED PATTERNS**

PRODUCT	PATTERNS
Eldorado Stone®	Ashlar, Bluffstone, Broken Top, Castlestone, Cliffstone, Coarsed Stone, Coastal Ledge, Coastal Reef, Cobblestone, Country Rubble, Cut Coarse Stone, Cypress Ridge, European Ledge, Fieldledge, Hillstone, Ledgecut <sub>33</sub> , Limestone, Longitude, Mountain Ledge, Mountain Ledge Panel, River Rock, Roughcut, Rustic Ledge, Shadow Rock, Stacked Stone, Top Rock, Weather Edge,
Eldorado Brick®	Modena Brick, Roma Brick, Tundra Brick, Via Brick,
Eldorado Adobe®	Camino Adobe, Capistrano Adobe

**DIVISION: 04 00 00—MASONRY****Section: 04 71 00—Manufactured Brick Masonry****Section: 04 73 00—Manufactured Stone Masonry****REPORT HOLDER:**

WESTLAKE ROYAL STONE, LLC

**EVALUATION SUBJECT:**

ELDORADO STONE®, ELDORADO BRICK® AND ELDORADO ADOBE® VENEERS

**1.0 REPORT PURPOSE AND SCOPE****Purpose:**

The purpose of this evaluation report supplement is to indicate that Eldorado Stone®, Eldorado Brick® and Eldorado Adobe® Veneers, described in ICC-ES evaluation report ESR-1215, have also been evaluated for compliance with CBC Chapters 8, 14, 21, 21A and 25 and CRC Chapters 3 and 7.

**Applicable code editions:**

- 2013 *California Building Code*® (CBC)
- 2013 *California Residential Code*® (CRC)

**2.0 CONCLUSIONS****2.1 CBC:**

The Eldorado Stone®, Eldorado Brick® and Eldorado Adobe® Veneers, described in Sections 2.0 through 7.0 of the evaluation report ESR-1215, comply with CBC Sections 803.1.1, 1404.4, 2101.2.6, and 2101A.2.6, provided the design and installation are in accordance with the 2012 *International Building Code*® (IBC) provisions noted in the evaluation report and the additional requirements of CBC Sections 1405.1.1, 1405.3 and 1410, as applicable.

**2.2 CRC:**

The Eldorado Stone®, Eldorado Brick® and Eldorado Adobe® Veneers, described in Sections 2.0 through 7.0 of the evaluation report ESR-1215, comply with the flame spread and smoke developed requirements of CRC Section R302.9 and with CRC Section R703, provided the design and installation are in accordance with the 2012 *International Residential Code*® (IRC) provisions noted in the evaluation report and the additional requirements of CRC Sections R301.1.3 and R702.7.

This supplement expires concurrently with the evaluation report, reissued November 2023.

**DIVISION: 04 00 00—MASONRY****Section: 04 71 00—Manufactured Brick Masonry****Section: 04 73 00—Manufactured Stone Masonry****REPORT HOLDER:****WESTLAKE ROYAL STONE, LLC****EVALUATION SUBJECT:****ELDORADO STONE®, ELDORADO BRICK® AND ELDORADO ADOBE® VENEERS****1.0 REPORT PURPOSE AND SCOPE****Purpose:**

The purpose of this evaluation report supplement is to indicate that Eldorado Stone, Eldorado Brick and Eldorado Adobe Veneers, described in ICC-ES evaluation report ESR-1215, have also been evaluated for compliance with the codes noted below.

**Applicable code editions:**

- 2014 *Florida Building Code—Building*
- 2014 *Florida Building Code—Residential*

**2.0 CONCLUSIONS**

The Eldorado Stone, Eldorado Brick and Eldorado Adobe Veneers, described in Sections 2.0 through 7.0 of the evaluation report ESR-1215, comply with the *Florida Building Code—Building* and the *Florida Building Code—Residential*, provided the design and installation are in accordance with the 2012 *International Building Code*® (IBC) provisions noted in the evaluation report, provided that the veneer has a clearance to the final earth grade on the exterior of the building as required by Section 1403.7 of the *Florida Building Code—Building* or Section R318.7 of the *Florida Building Code—Residential*, as applicable.

Use of the Eldorado Stone, Eldorado Brick and Eldorado Adobe Veneers for compliance with the High-Velocity Hurricane Zone provisions of the *Florida Building Code—Building* and the *Florida Building Code—Residential* has not been evaluated, and is outside the scope of this evaluation report.

For products falling under Florida Rule G1G20-3, verification that the report holder's quality assurance program is audited by a quality assurance entity approved by the Florida Building Commission for the type of inspections being conducted is the responsibility of an approved validation entity (or the code official when the report holder does not possess an approval by the Commission).

This supplement expires concurrently with the evaluation report, reissued November 2023.

## Safety Data Sheet (SDS)

**Product:** Adhered Masonry Stone Veneer (AMSV)

**SDS No:** 010

**Preparation Date:** 05/31/2015

**Version No.:** 1.0

**Revision Date:** 12/07/2015

### SECTION 1. IDENTIFICATION OF THE MIXTURE AND SUPPLIER

#### 1.1 Product Identifier:

**Product name:** Adhered Masonry Stone Veneer  
**Product code:** Various  
**Formula:** Mixture

#### 1.2 Relevant identified uses of the substance or mixture and uses advised against:

**Relevant identified uses:** Interior or Exterior Wall or Surface Covering  
**Uses advised against:** Any use other than those recommended

#### 1.3 Details of the supplier of the safety data sheet:

**Manufacturer/Supplier:** Eldorado Stone  
**Street Address:** 1370 Grand Avenue, San Marcos, CA  
**Country ID/Postcode:** USA/92078  
**Customer service telephone:** 760-736-3232/ 800-925-1491

#### 1.4 Emergency telephone number:

**Emergency telephone number:** 877-347-8096  
**Hours available:** 24 hours a day / 7 days a week

### SECTION 2. HAZARDS IDENTIFICATION

#### 2.1 Classification of the mixture:

Adhered Masonry Stone Veneer (AMSV) are defined by OSHA as an article (under normal conditions, no more than minute or trace amounts of a hazardous chemicals are released and the article does not pose a physical hazard or health risk to employees).

An SDS not is required for articles; however, this SDS is provided to communicate hazards associated where activities related to the Adhered Masonry Stone Veneer (cutting, grinding, crushing, drilling or breaking) may result in the release of a hazardous substance in DUST.

**GHS Classification(s) for Adhered Masonry Stone Veneer according to OSHA Hazard Communication Standard (29 CFR 1910.1200) under normal handling conditions:**

None



**GHS Classification(s) for dust generated from cutting, grinding, crushing, drilling or breaking of Adhered Masonry Stone Veneer according to OSHA Hazard Communication Standard (29 CFR 1910.1200) under use conditions that may result in the release of hazardous substances:**

Skin Corrosion/Irritation, Category 2 (H315)

Eye Damage/Irritation, Category 2 (H319)

Specific Target Organ Toxicity-Repeated Exposure (STOT-RE), Category 1 (H372)

**Note:** The AMSV dust classifications are based on (1) individual ingredient classifications (i.e., Silica Sand [SiO<sub>2</sub>], pumice, expanded shale, expanded clay or expanded slate, Portland Cement, Fly Ash, etc.), (2) the final chemical composition of the AMSV (based on cement chemistry) and (3) the form of the material (dust). Further, the Specific Target Organ Toxicity-Repeat Exposure is a conservative classification based on the potential presence of respirable crystalline silica. Eldorado Stone has not performed analysis for the presence of respirable crystalline silica under these handling conditions.

**Additional information:**

For full text of GHS Hazard statements (H-statements) and associated Precautionary statements (P-statements), see below.

## 2.2 Label elements

The Hazard Pictograms, Signal Word and Precautionary Statements only apply to activities that may release hazardous substances from the AMSV (i.e., cutting / grinding / crushing / drilling / breaking).

**No Hazard Pictograms, Signal Word or Precautionary Statements are applicable to the Adhered Masonry Stone Veneer.**

Hazard Pictograms that apply to the dust generated from cutting, grinding, crushing, drilling or breaking of the Adhered Masonry Stone Veneer:



**Signal Word:**

Danger

**Hazard Statements:**

**(For AMSV Dust Generated from Cutting, Grinding, Crushing, Drilling or Breaking)**

H315: Causes skin irritation.

H319: Causes eye irritation.

H372: Causes damage to lungs through prolonged or repeated inhalation exposure.

**Precautionary Statements:**

**(For AMSV Dust Generated from Cutting, Grinding, Crushing, Drilling or Breaking)**

P260: Do not breathe dust.

P270: Do not eat, drink or smoke while using this product.

P271: Use only outdoors or in a well-ventilated area.

P264: Wash thoroughly after handling.

P280: Wear protective gloves/protective clothing/eye protection/face protection.

P302 + P352: IF ON SKIN: Wash with plenty of water.

P304 + P340: IF INHALED: Remove person to fresh air and keep comfortable for breathing.

P305 + P351 + P338: IF IN EYES: Rinse cautiously with water for several minutes. Remove contact lenses, if present and easy to do. Continue rinsing.

**Product: Adhered Masonry Stone Veneer (AMSV)**

SDS No: 001

Version No.: 1.0

Preparation Date: 05/31/2015

Revision Date: 12/07/2015

P314: Get medical advice/attention if you feel unwell.  
P321: See the SDS for specific treatment.  
P332 + P313: If skin irritation occurs, get medical advice/attention.  
P337 + 313: If eye irritation persists, get medical attention.  
P362 + P364: Take off contaminated clothing and wash before reuse.  
P501: Dispose of generated dust in accordance with local / regional / national / international regulations.

### 2.3 Other hazards related to AMSV dust generated from cutting, grinding, crushing, drilling or breaking of adhered masonry stone veneer.

**Listed Carcinogens:** Silica dust (respirable, crystalline fraction) in the form of quartz.

**IARC:** Yes    **NTP:** Yes    **OSHA:** No    **Other:** No (European Union)

**Hazardous Properties:** Dust generated from cutting, grinding, crushing, drilling or breaking may cause eye damage and skin irritation. May be irritating to respiratory tract. Respirable crystalline silica may cause damage to lungs upon repeated inhalation exposures.

## SECTION 3. COMPOSITION / INFORMATION ON INGREDIENTS

### 3.1 Description of the mixture:

The product is a solid concrete block that, when subjected to cutting, grinding, crushing, drilling or breaking, may form hazardous dusts.

### 3.2 Hazardous Ingredients:

Name	CAS No.	Weight %	GHS Classification per OSHA Hazard Communication (29 CFR 1900.1200)
Silica dioxide (quartz)	14808-60-7	0-90%	STOT-RE, Category 1 (H372)*
Portland Cement	65597-15-1	8-15%	Skin Corrosion/Irritation, Category 2 (H315) Eye Damage/Irritation, Category 1 (H318) STOT-Single Exposure, Category 3 (H335)
Fly Ash	68131-74-8	0-4%	STOT-RE, Category 1 (H372*)
Iron Oxide Pigments	001309-37-1	0-1%	Not considered a hazardous ingredient.

\* The Specific Target Organ Toxicity-Repeat Exposure (STOT-RE) is a conservative classification based on the presence/potential presence of respirable crystalline silica.

## SECTION 4. FIRST AID MEASURES

### 4.1 Description of first aid measures:

**Inhalation:** If dust generated from cutting, grinding, crushing, drilling or breaking is inhaled, remove person to fresh air and keep comfortable for breathing. Get medical attention if respiratory symptoms persist.

**Product:** Adhered Masonry Stone Veneer (AMSV)

SDS No: 001

Version No.: 1.0

Preparation Date: 05/31/2015

Revision Date: 12/07/2015

**Skin contact:** If dust generated from cutting, grinding, crushing, drilling or breaking is on skin, wash with soap and water. Get medical advice/attention if irritation occurs/persists.

**Eye contact:** If dust generated from cutting, grinding, crushing, drilling or breaking is in eyes, rinse cautiously with water for several minutes. Get medical advice/attention if irritation occurs/persists.

**Ingestion:** No specific first aid measures are required.

#### **4.2 Most important health effects related to AMSV dust generated from cutting, grinding, crushing, drilling or breaking, both acute and delayed:**

**Acute effects:** Direct exposure to dust generated from cutting, grinding, crushing, drilling or breaking may cause eye damage/irritation, skin irritation and respiratory irritation. Dust can dry and irritate the skin and cause dermatitis. Can irritate eyes and skin through mechanical abrasion.

**Delayed effects:** Chronic exposure to inhaled dust generated from cutting, grinding, crushing, drilling or breaking may cause lung damage from repeated exposure. Chronic inhalation of dusts containing free crystalline silica may result in silicosis.

#### **4.3 Indication of any immediate medical attention and special treatment needed:**

Seek first aid or call a doctor if contact with dust generated from cutting, grinding, crushing, drilling or breaking with eyes occurs and irritation remains after rinsing.

## **SECTION 5. FIREFIGHTING MEASURES**

### **5.1 Extinguishing Media:**

**Suitable extinguishing media:** Product is not flammable. Use extinguishing media appropriate for surrounding fire.

**Unsuitable extinguishing media:** Not applicable; the product is not flammable.

### **5.2 Special hazards arising from the substance or mixture:**

**Hazardous combustion products:** None known.

### **5.3 Advice for firefighters:**

**Special protective equipment and precautions for firefighters:** As with any fire, wear self-contained breathing apparatus, MSHA/NIOSH (approved or equivalent) and full protective gear.

## **SECTION 6. ACCIDENTAL RELEASE MEASURES**

### **6.1 Personal precautions, protective equipment and emergency procedures associated with AMSV dust generated from cutting, grinding, crushing, drilling or breaking:**

**For Non-Emergency Personnel:**

**Product: Adhered Masonry Stone Veneer (AMSV)**

SDS No: 001

Version No.: 1.0

Preparation Date: 05/31/2015

Revision Date: 12/07/2015

**Protective equipment:** In case of exposure to dust generated from cutting, grinding, crushing, drilling or breaking, wear specified protective equipment. (See Section 8).

**Emergency procedures:** Avoid the creation of dust generated from cutting, grinding, crushing, drilling or breaking. Use scooping, water/flushing/misting or vacuum cleaning systems. Wet methods of cutting, grinding, crushing, drilling or breaking are the preferred method of controlling dust.

**For Emergency Responders:**

**Protective equipment:** In case of exposure to dust generated from cutting, grinding, crushing, drilling or breaking, wear specified protective equipment. In case of fire, use self-contained breathing apparatus with full face mask.

## 6.2 Environmental Precautions

Discard any product or dust residue in compliance with local regulations.

## 6.3 Methods and material for containment and cleaning up:

**For containment and cleaning up:** After cutting, grinding, crushing, drilling or breaking activities, use scooping, water spraying/flushing/misting or ventilated vacuum cleaning system to clean up dust generated from cutting, grinding, crushing, drilling or breaking. Use closed containers. Do not use pressurized air to clean dust.

**Other information:** Take measures to avoid dust formation during cutting, grinding, crushing, drilling or breaking activities.

# SECTION 7. HANDLING AND STORAGE

## 7.1 Precautions for safe handling:

**Protective measures:** Avoid contact with dust generated from cutting, grinding, crushing, drilling or breaking with skin, eyes, and clothing. Avoid breathing dust. Wash thoroughly after handling. Wet methods of cutting, grinding, crushing, drilling or breaking are the preferred method of controlling dust.

**Measures to prevent fires:** Not applicable; material is non-flammable.

**Measures to prevent dust generation:** Vacuum, scoop, or use water mist/spray/flush to remove generated dust during cutting, grinding, crushing, drilling or breaking activities. Do not use pressurized air. Wet methods of cutting, grinding, crushing, drilling or breaking are the preferred method of controlling dust.

**Measures to protect the environment:** Not applicable; material is not an environmental hazard.

**Advice on general occupational hygiene:**

Practice good housekeeping. Avoid formation of dust generated from cutting, grinding, crushing, drilling or breaking. Do not breathe dust. Use adequate exhaust ventilation, dust collection and/or water mist to maintain airborne dust concentrations below permissible exposure limits. Respirable crystalline silica dust may be in the air without a visible dust cloud. In case of insufficient ventilation, wear a NIOSH approved respirator for silica dust when using, handling, storing or disposing dust from this product. Do not permit dust to collect on walls, floors, sills, ledges, machinery, or equipment. Maintain and test ventilation and dust collection equipment. Wash or vacuum clothing that has become dusty. Avoid eating, smoking, or drinking while handling the material.

**7.2 Conditions for safe storage, including any incompatibilities:**

**Storage conditions:** Minimize dust produced during loading and unloading.

**SECTION 8. EXPOSURE CONTROLS / PERSONAL PROTECTION**

**8.1 Control parameters applicable to AMSV dust generated from cutting, grinding, crushing, drilling or breaking:**

**United States**

<b>OCCUPATIONAL EXPOSURE LIMITS FOR HAZARDOUS SUBSTANCES IN THE WORKPLACE</b>					
<b>SUBSTANCE</b>		<b>OSHA PEL TWA / STEL (mg/m<sup>3</sup>)</b>	<b>NIOSH REL TWA / STEL (mg/m<sup>3</sup>)</b>	<b>ACGIH TLV TWA / STEL (mg/m<sup>3</sup>)</b>	<b>CAL - OSHA PEL (mg/m<sup>3</sup>)</b>
<b>Calcium Oxide</b>		5	2	2	-
<b>Crystalline Silica</b>	Total Quartz	$30 \div (\%SiO_2+2)$ (Total Quartz)	-	-	0.3
	Respirable Crystalline Silica	$10 \div (\%SiO_2+2)$	0.05	0.025 ( $\alpha$ -quartz & cristobalite)	0.1
	Cristobalite	-	0.05	0.025 ( $\alpha$ -quartz & cristobalite)	0.05 (respirable)
<b>Particulates Not Otherwise Regulated</b>	Total	15	15	-	10
	Respirable	5	5	-	5

**8.2 Exposure controls:**

**8.2.1. Exposure Controls**

**Engineering controls:**

Ventilation should be adequate to maintain the ambient workplace atmosphere below the exposure limit(s). Use general and local exhaust ventilation and dust collection systems as necessary to minimize exposure to dust generated from cutting, grinding, crushing, drilling or breaking. Wet methods of cutting, grinding, crushing, drilling or breaking are the preferred method of controlling dust.

### 8.2.2. Personal Protective Equipment

**Respiratory protection:** Wear a NIOSH/MSHA approved particulate respirator if exposure to dust generated from cutting, grinding, crushing, drilling or breaking is unavoidable and where occupational exposure limits may be exceeded. If airborne dust exposures exceed the PEL or TLV, a self-contained breathing apparatus or airline respirator is recommended.

**Eye and face protection:** If eye contact with dust generated from cutting, grinding, crushing, drilling or breaking is anticipated, wear protective glasses with side shields. Avoid contact lenses.

**Hand and skin protection:** Wear gloves and protective clothing to minimize skin contact with dust generated from cutting, grinding, crushing, drilling or breaking. Wash hands with soap and water after contact with material.

**Foot protection:** Wear American National Standards Institute (ANSI) approved hard-toed safety shoes when handling AMSV.

### 8.2.3. Environmental Exposure Controls

**Instructions to prevent exposure:** No special requirements. Discard any product or dust residue in compliance with local regulations. Wet methods of cutting, grinding, crushing, drilling or breaking are the preferred method of controlling dust.

## SECTION 9. PHYSICAL AND CHEMICAL PROPERTIES

### 9.1 Information on basic physical and chemical properties:

Property	Value	Property	Value
<b>Appearance:</b>	Simulated Stone	<b>Lower Explosive Limit (LEL):</b>	Not applicable
<b>Odor</b>	Odorless	<b>Vapor Pressure (Pa):</b>	Not applicable
<b>Odor threshold</b>	Not applicable	<b>Vapor Density:</b>	Not applicable
<b>pH (25°C):</b>	Not available	<b>Relative Density/Specific Gravity:</b>	1.4 – 1.6
<b>Melting/Freezing Point (°C):</b>	Not applicable	<b>Water Solubility:</b>	Negligible
<b>Initial Boiling Point (°C):</b>	Not applicable	<b>Partition Coefficient: <i>n</i>-octanol/water:</b>	Not applicable
<b>Boiling Range (°C):</b>	Not applicable	<b>Auto-ignition Temperature (°C):</b>	Not applicable
<b>Flash Point(°C):</b>	Not applicable	<b>Decomposition Temperature (°C):</b>	Not available
<b>Evaporation Rate:</b>	Not applicable	<b>Viscosity:</b>	Not applicable
<b>Flammability (solid, gas):</b>	Not combustible	<b>Explosive Properties:</b>	Not applicable

**Product:** Adhered Masonry Stone Veneer (AMSV)

SDS No: 001

Version No.: 1.0

Preparation Date: 05/31/2015

Revision Date: 12/07/2015

Property	Value	Property	Value
Upper Explosive Limit (UEL):	Not applicable	Oxidizing Properties:	Not applicable

## SECTION 10. STABILITY AND REACTIVITY

<b>10.1 Reactivity</b>	Stable inert material
<b>10.2 Chemical stability</b>	Stable inert material
<b>10.3 Possibility of hazardous reactions</b>	None known.
<b>10.4 Conditions to avoid</b>	None known
<b>10.5 Incompatible materials</b>	None known
<b>10.6 Hazardous decomposition products</b>	None known

## SECTION 11. TOXICOLOGICAL INFORMATION

### 11.1 Information on toxicological effects:

<b>Acute toxicity:</b>	No data is available on the AMSV dust generated from cutting, grinding, crushing, drilling or breaking. No ingredients within the mixture exhibit acute toxicity.
<b>Skin corrosion/irritation:</b>	Contact with dust may cause skin irritation.
<b>Serious eye damage / irritation:</b>	Eye Irritant. Eye contact with dust generated from cutting, grinding, crushing, drilling or breaking may cause eye irritation.
<b>Respiratory or skin sensitization:</b>	No data is available on the AMSV dust generated from cutting, grinding, crushing, drilling or breaking. No ingredients exhibit sensitization effects.
<b>Germ cell mutagenicity:</b>	No data is available on the AMSV dust generated from cutting, grinding, crushing, drilling or breaking. No ingredients exhibit mutagenic effects.
<b>Carcinogenicity:</b>	No data is available on the AMSV dust generated from cutting, grinding, crushing, drilling or breaking. Crystalline silica (respirable) has been identified as a carcinogen by IARC and NTP.
<b>Reproductive toxicity:</b>	No data is available on the AMSV dust generated from cutting, grinding, crushing, drilling or breaking. No ingredients exhibit reproductive toxicity.
<b>STOT single exposure:</b>	No data is available on the AMSV dust generated from cutting, grinding, crushing or drilling.

**Product: Adhered Masonry Stone Veneer (AMSV)**

SDS No: 001

Version No.: 1.0

Preparation Date: 05/31/2015

Revision Date: 12/07/2015

**STOT repeated exposure:** No data is available on the repeated inhalation of AMSV dust generated from cutting, grinding, crushing, drilling or breaking. Repeated inhalation of AMSV dust generated from cutting grinding, crushing or breaking may cause lung damage if respirable crystalline silica is present. Crystalline silica (respirable) has been shown to cause silicosis after repeated exposure.

**Aspiration hazard:** Not applicable, the material is a not a liquid.

## SECTION 12. ECOLOGICAL INFORMATION

No data available on the AMSV dust generated from cutting, grinding, crushing, drilling or breaking.

## SECTION 13. DISPOSAL CONSIDERATIONS

Considered a non-hazardous waste. Follow applicable federal, state and local regulations.

## SECTION 14. TRANSPORT INFORMATION

### Regulatory Entity

<b>US DOT</b>	Shipping Name	Not regulated
	Hazard Class	Not regulated
	ID Number	Not regulated
	Packing Group	Not regulated

## SECTION 15. REGULATORY INFORMATION

### 15.1 Safety, health and environmental regulations / legislation specific to the mixture:

#### United States Regulations

<b>Toxic Substances Control Act (TSCA) Inventory Status</b>	All components of this product are listed on the TSCA Inventory or are exempt from listing.	
<b>SARA (Section 311/312)</b>	Reactive Hazard	No
	Pressure Hazard	No
	Fire Hazard	No
	Immediate/Acute Toxicity	No
	Delayed/Chronic Toxicity	Yes – respirable crystalline silica
<b>SARA Section 313 Information:</b>	This product does not contain any toxic chemicals listed under 313 of the Emergency Planning and Community Right-to-Know Act of 1986 (EPCRA).	
<b>Clean Air Act (CAA)</b>	This product does not contain any toxic chemicals listed under the CAA at concentrations greater than 0.1%.	
	VOC Content (weight %).	0 wt. %



**Product: Adhered Masonry Stone Veneer (AMSV)**

SDS No: 001

Version No.: 1.0

Preparation Date: 05/31/2015

Revision Date: 12/07/2015

---

### United States Regulations

---

<b>Volatile Organic Compounds (VOCs)</b>	Remarks:	Estimated
<b>State Right-to-Know Status</b>	California Prop. 65:	Crystalline Silica.
	Massachusetts:	Silica, Crystalline-Quartz; Calcium oxide; Calcium carbonate (Limestone); Portland cement; Iron oxide dust.
	New Jersey	Silica, Crystalline-Quartz; Calcium oxide; Calcium carbonate (Limestone); Cement, Portland, Chemicals; Iron oxide.
	Pennsylvania:	Quartz (silica dioxide); Calcium oxide; Calcium carbonate (Limestone); Cement, Portland, Chemicals; Iron oxide.

---

**Dispose of all waste product and containers in accordance with federal, state and local regulations.**

## SECTION 16. OTHER INFORMATION

### 16.1 Indication of changes:

Initial SDS prepared on 04-07-2015; Revised 12/07/2015

### 16.2 Abbreviations and acronyms:

AMSV	Adhered Masonry Stone Veneer
ANSI:	American National Standards Institute
CAA:	Clean Air Act
Cal/OSHA:	California Department of Industrial Relations - Division of Occupational Safety and Health
CAS:	Chemical Abstract Service Registry Number
CFR:	Code of Federal Regulations
CWA:	Clean Water Act
GHS:	Globally Harmonized System of Classification and Labeling
HMIS:	Hazardous Materials Identification System
IARC:	International Agency for Research on Cancer
LEL:	Lower explosive limit
MSHA:	Mine Safety and Health Administration
NA:	Not Applicable
NIOSH:	National Institute of Occupational Safety and Health
NTP:	National Toxicology Program
OSHA:	Occupational Safety and Health Administration
Pa:	Pascal
PEL:	Permissible exposure limit
SARA:	Superfund Amendments and Reauthorization Act
SDS:	Safety data sheet
STEL:	Short-term exposure limit
STOT-RE:	Specific target organ toxicity-repeated exposure

**Product: Adhered Masonry Stone Veneer (AMSV)**

SDS No: 001

Version No.: 1.0

Preparation Date: 05/31/2015

Revision Date: 12/07/2015

---

STOT-SE: Specific target organ toxicity-single exposure  
TLV: Threshold limit value  
TSCA: Toxic Substances Control Act  
TWA: Time-weighted average  
UEL: Upper explosive limit  
USA: United States of America  
US DOT: United States of Department of Transportation  
VOC: Volatile organic compound

### 16.3 Other hazards:

**Hazardous Materials Identification System (HMIS)** Degree of hazard: 0 = low, 4 = extreme

**Health:** 1\*                      **Flammability:** 0                      **Reactivity:** 0

*\* Dust generated from cutting, grinding, crushing, drilling or breaking activities may result in a chronic health hazard (Category 3 Health Hazard)*

**Personal Protection:** B

#### **Disclaimer:**

*This SDS has been prepared in accordance with the Hazard Communication Rule 29 CFR 1910.1200. Information herein is based on data considered to be accurate as of date prepared. No warranty or representation, express or implied, is made as to the accuracy or completeness of this data and safety information. No responsibility can be assumed for any damage or injury resulting from abnormal use, failure to adhere to recommended practices, or from any hazards inherent in the nature of the product.*

— End of Safety Data Sheet (SDS) —